



# SAE Cavity cartridges

TECHNICAL CATALOGUE



**Additional information**

This catalogue shows the product in the most standard configurations.  
Please contact our Sales Dpt. for more detailed information or special requests.

**WARNING!**

All specifications of this catalogue refer to the standard product at this date.  
Walvoil, oriented to a continuous improvement, reserves the right to discontinue, modify or revise the specifications, without notice.

WALVOIL IS NOT RESPONSIBLE FOR ANY DAMAGE CAUSED BY AN  
INCORRECT USE OF THE PRODUCT.

13<sup>th</sup> edition May 2020

## Pressure control valves

Pressure relief valves									
Hydraulic diagram	Valve	Execution	Operation	Control type	Max. flow up to		Max. press. up to		Page
					l/min	US gpm	bar	psi	
<b>2 way</b>									
	<b>MC12A</b>	poppet	direct	mechanic	100	26	350	5100	11
	<b>MC10M</b>	poppet	direct	mechanic	70	18.5	350	5100	13
	<b>MC..R</b>	poppet	direct	mechanic	50	13.2	350	5100	15
	<b>MC08Y</b>	poppet	direct	solenoid proportional	1	0.3	350	5100	17
	<b>MC10T</b>	poppet	direct	solenoid proportional	3	0.8	350	5100	19
	<b>MC10T HF type</b>			solenoid proportional					
	<b>MC10X</b>	poppet	direct	solenoid proportional	3.5	0.9	350	5100	23
	<b>MC10X HF type</b>			solenoid proportional					
	<b>MD..M</b>	poppet	direct	mechanic	100	26.4	350	5100	27
	<b>MG..A</b>	poppet	direct	mechanic	100	26.4	350	5100	33
	<b>MP..A</b>	spool	pilot	mechanic	100	26.4	350	5100	35
	<b>MP16M</b>	spool	pilot	mechanic	400	105.67	350	5100	39
	<b>MP..T</b>	spool	pilot	solenoid proportional	120	31.7	350	5100	41
	<b>MP..X</b>	spool	pilot	solenoid proportional	120	31.7	350	5100	45
	<b>MP16Y</b>	spool	pilot	solenoid proportional	150	40	350	5100	49

## Pressure control valves

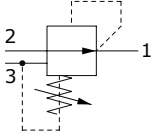
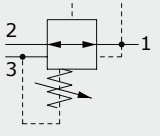
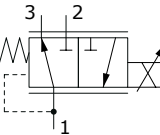
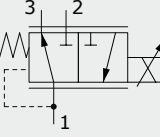
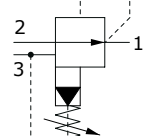
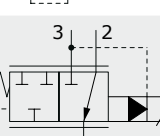
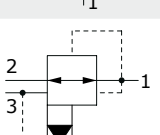
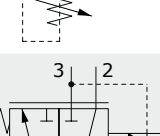
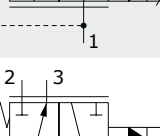
Pressure reducing valves									
Hydraulic diagram	Valve	Execution	Operation	Control type	Max. flow up to		Max. press. up to		Page
					l/min	US gpm	bar	psi	
<b>3 way</b>									
	<b>RB..A</b>	spool	direct	mechanic	30	7.9	line 1 = 150 line 2 = 350	line 1 = 2200 line 2 = 5100	51
	<b>RD..A</b>	spool	direct	mechanic	30	7.9	line 1 = 150 line 2 = 350	line 1 = 2200 line 2 = 5100	53
	<b>RD08W</b>	spool	direct	solenoid proportional	4	1.05	350	5100	55
	<b>RD08S RD08T</b>	spool	direct	solenoid proportional	12	3.17	210	3050	57
	<b>RM..A</b>	spool	pilot	mechanic	150	40	line 1 = 350 line 2 = 350	line 1 = 5100 line 2 = 5100	61
	<b>RM..W</b>	spool	pilot	solenoid proportional	150	40	350	5100	65
	<b>RP..A</b>	spool	pilot	mechanic	150	40	line 1 = 210 line 2 = 350	line 1 = 3050 line 2 = 5100	69
	<b>RP..W</b>	spool	pilot	solenoid proportional	150	40	350	5100	73
	<b>RP08X</b>	spool	pilot	solenoid proportional	15	4	350	5100	77

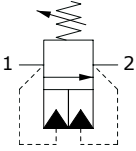
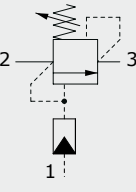
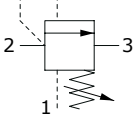
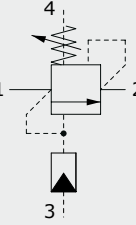

## Pressure control valves

### Sequence valves

Hydraulic diagram	Valve	Execution	Operation	Control type	Max. flow up to		Max. press. up to		Page	
					l/min	US gpm	bar	psi		
<b>2 way</b>										
	<b>SW..A</b>	spool	pilot	mechanic	180	48	350	5100	79	
<b>3 way</b>										
	<b>SE..A</b>	spool	direct	mechanic	20	5.3	210	3050	81	
	<b>SP10A</b>	spool	pilot	mechanic	50	13	350	5100	83	
<b>4 way</b>										
	<b>SG12A</b>	poppet	direct	mechanic	50	13	300	4350	85	

## Motion control valves

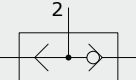
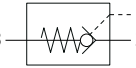
### Check valves and shuttle valves

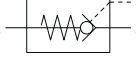
Hydraulic diagram	Valve	Execution	Operation	Control type	Max. flow up to		Max. press. up to		Page	
					l/min	US gpm	bar	psi		
<b>2 way</b>										
	<b>UC..A</b>	poppet	direct	mechanic	100	26	350	5100	87	
<b>3 way</b>										
	<b>UT..A</b>	ball	/	mechanic	20	5.3	350	5100	89	
	<b>BC..A</b>	poppet	direct	mechanic	100	26	350	5100	91	
	<b>BC..B</b>	poppet	direct	mechanic	100	26	350	5100	91	
	<b>BC..C</b>	poppet	direct	mechanic	60	16	350	5100	91	

## Motion control valves

Counterbalance valves									
Hydraulic diagram	Valve	Execution	Operation	Control type	Max. flow up to		Max. press. up to		Page
					l/min	US gpm	bar	psi	
<b>3 way</b>									
	<b>CA..A</b>	poppet	/	mechanic	90	23.8	350	5100	95
	<b>CC..A</b>	poppet	/	mechanic	150	40	350	5100	99

## Flow control valves

Flow restrictor									
Hydraulic diagram	Valve	Execution	Operation	Control type	Max. flow up to		Max. press. up to		Page
					l/min	US gpm	bar	psi	
<b>2 way</b>									
	<b>NB..A</b>	poppet	/	mechanic	100	26	350	5100	103
	<b>NU..A</b>	poppet	/	mechanic	100	26	350	5100	105
	<b>NT..A</b>	poppet	/	mechanic	100	26	350	5100	107
	<b>EE..X</b>	spool	direct	solenoid proportional	60	16	315	4600	109
	<b>EC..T</b>	poppet	pilot	solenoid proportional	97	25.6	350	5100	113

## Flow control valves

### Flow control pressure compensated valves

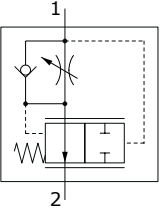
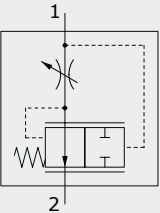
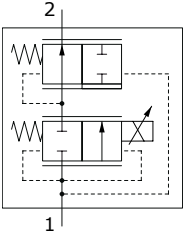
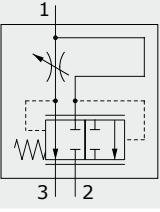
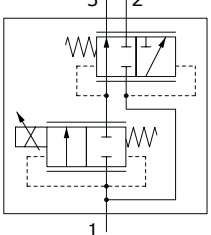
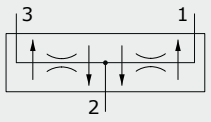
Hydraulic diagram	Valve	Execution	Operation	Control type	Max. flow up to		Max. press. up to		Page	
					l/min	US gpm	bar	psi		
<b>2 way</b>										
	<b>PW..A</b>	spool	direct	mechanic	90	24	315	4600	117	
	<b>PU..A</b>	spool	direct	mechanic	90	24	315	4600	121	
	<b>PU..X</b>	spool	direct	solenoid proportional	90	24	315	4600	125	
<b>3 way</b>										
	<b>PP..A</b>	spool	direct	mechanic	90	24	350	5100	129	
	<b>PP..X</b>	spool	direct	solenoid proportional	90	24	350	5100	133	
	<b>PD</b>	spool	direct	mechanic	150	40	210	3045	137	

## Logic valves

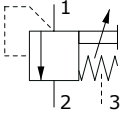
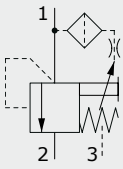
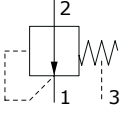
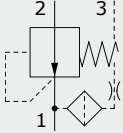
Logic valves									
Hydraulic diagram	Valve	Execution	Operation	Control type	Max. flow up to		Max. press. up to		Page
					l/min	US gpm	bar	psi	
	<b>LA..QA</b>	spool	pilot to close	/	190	50.2	350	5100	139
	<b>LB..QA</b>	spool	venting to open	/	190	50.2	350	5100	141
	<b>LC..QA</b>	spool	venting to close	/	150	39.6	350	5100	143
	<b>LD..QA</b>	spool	pilot to open	/	150	39.6	350	5100	145



## Directional control valves

### Solenoid directional valves

Hydraulic diagram	Valve	Execution	Operation	Control type	Max. flow up to		Max. press. up to		Page	
					l/min	US gpm	bar	psi		
<b>2 way / 2 positions</b>										
	<b>EA08<sup>(1)</sup></b>	poppet	direct	solenoid	1	0.6	350	5100	147	
	<b>EE..A<sup>(1)</sup></b>	spool	direct	solenoid	40	10.5	210	3050	149	
	<b>EC..M<sup>(1)</sup></b>	poppet	pilot	solenoid	150	40	380	5500	153	
	<b>EF..M<sup>(1)</sup></b>	poppet	pilot	solenoid	150	40	380	5500	157	
	<b>EH..M<sup>(1)</sup></b>	poppet	pilot	solenoid	150	40	380	5500	161	
	<b>EW...</b>	poppet	direct	solenoid	50	13.2	210	3050	165	
	<b>EW..M</b>	poppet	direct	solenoid	40	10.5	350	5100	169	
<b>3 way / 2 positions</b>										
	<b>EJ08F</b>	spool	direct	solenoid	12	3.2	50	725	173	
	<b>EJ8CA</b>	spool	direct	solenoid	10	2.6	70	18.5	175	
	<b>EJ08G</b>	spool	direct	solenoid	3	0.8	350	5100	177	
	<b>EJ..M<sup>(2)</sup></b>	spool	direct	solenoid	40	10.5	250	3600	179	
	<b>EJ12A<sup>(2)</sup></b>	spool	direct	solenoid	40	10.5	210	3050	185	
	<b>EL...</b>	poppet	direct	solenoid	20	5.3	210	3050	189	
	<b>EL08B</b>	poppet	direct	solenoid	10	2.6	250	3600	191	
<b>4 way / 2 positions</b>										
	<b>ER..M<sup>(2)</sup></b>	spool	direct	solenoid	60	15.8	250	3600	193	
<b>4 way / 3 positions</b>										
	<b>ET..M<sup>(2)</sup></b>	spool	direct	solenoid	40	10.5	210	3050	199	
	<b>ET12A<sup>(2)</sup></b>	spool	direct	solenoid	40	10.5	210	3050	203	

Note (1) the circuit shown are in normally open configuration; normally closed configuration is also available, see valves pages.  
 Note (2) the circuit shown are one type of available spools; for several types of spools see valves pages.

## Accessories

### Coils and connectors

- Types and ordering codes . . . . .page 206
- Dimensional data and features . . . . .page 207

### Adjustments

- Types and dimensions . . . . .page 212

### Emergency

- Types and dimensions . . . . .page 213

### Valve bodies

- 2 way bodies . . . . .page 215
- 3 way bodies . . . . .page 217
- 4 way bodies . . . . .page 219
- How to order valves with body . . . . .page 221

### Cavity tools and taps

- 2 way SAE cavity . . . . .page 222
- 3 way SAE cavity . . . . .page 223
- 4 way SAE cavity . . . . .page 224



## MC12A type pressure relief valves - 2 way

- Direct acting
- Poppet type
- From SAE12 cavities

Technical specifications and diagrams are measured with mineral oil of 46 cSt viscosity at 40°C (104°F) temperature.

### MC12A

Nominal flow		100 l/min (26.4 US gpm)
Max. pressure		350 bar (5100 psi)
Oil leakage		-
Fluid		mineral based oil
Viscosity		10-200 cSt
Max level of contamination		20/18/14 ISO4406
Fluid temperature	with NBR seals	from -20°C (-4°F) to 80°C (176°F)
	with FPM seals	from -20°C (-4°F) to 100°C (212°F)
Environmental temp. for working conditions		from -20°C (-4°F) to 50°C (122°F)
Cavity		SAE 12/2
Weight		0.86 kg (1.89 lb)

NOTE - For different conditions, please contact Walvoil Sales Dpt.

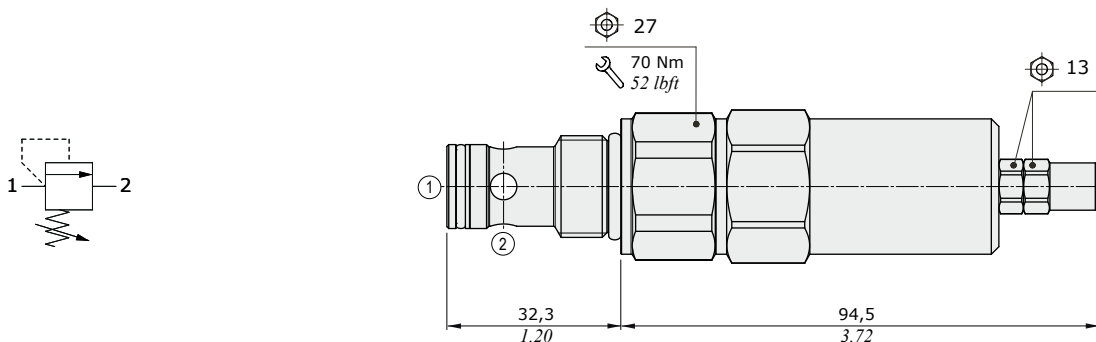

For dimensions with different type of adjustment see page 212

## Ordering codes and description composition

### MC12A/OS2B

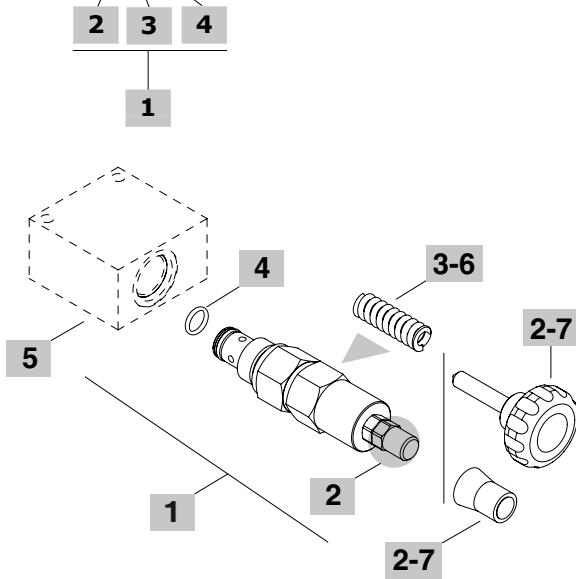

### 3 Pressure range

Standard setting is referred to 5 l/min (1.32 US gpm) flow

TYPE DESCRIPTION

- 1** Range 20÷100 bar (290÷1450 psi); Std. setting 50 bar (725 psi), pressure increase by steps of 5,7 bar (83 psi) per screw turn
- 2** Range 50÷200 bar (725÷2900 psi); Std. setting 150 bar (2175 psi), pressure increase by steps of 26,5 bar (348 psi) per screw turn
- 3** Range 150÷350 bar (725÷1450 psi); Std. setting 250 bar (3600 psi), pressure increase by steps of 35 bar (508 psi) per screw turn

### 4 Seals

TYPE DESCRIPTION

- B** **NBR (Buna)** o-ring seals, std configuration
- V** **FPM (Viton)** o-ring seals, contact Sales Dept.

### 5 Valve body

TYPE CODE DESCRIPTION

- SAE 12/2-G 1/2** 3CC1220D11 Aluminium body for cavity 12 valve, G 1/2 std thread

Note: aluminium body can stand up to 210 bar (3050 psi)

For steel bodies or different threading see from page 215

### 1 Cartridges

TYPE	CODE	DESCRIPTION
<b>MC12A/OS1B</b>	0MC12002000	Pressure range <b>1</b>
<b>MC12A/OS2B</b>	0MC12002001	Pressure range <b>2</b>
<b>MC12A/OS3B</b>	0MC12002002	Pressure range <b>3</b>

### 2 Adjustments

TYPE	DESCRIPTION
<b>S</b>	With screw
<b>V</b>	With handwheel (part code: see point <b>7</b> )
<b>X</b>	Valve set with antitampering cap (part code: see point <b>7</b> )

### 6 Springs

TYPE	CODE	DESCRIPTION
<b>1</b>	3ML1166804	Pressure range <b>1</b> - green band
<b>2</b>	3ML1146800	Pressure range <b>2</b> - blue band
<b>3</b>	3ML1166805	Pressure range <b>3</b> - red band

### 7 Accessories

TYPE	CODE	DESCRIPTION
-	4VL2407100	Handwheel
-	4COP120420	Antitampering cap

## Rating diagrams

**MC12A pressure vs. flow**  
Std. setting at 5 l/min (1.32 US gpm)

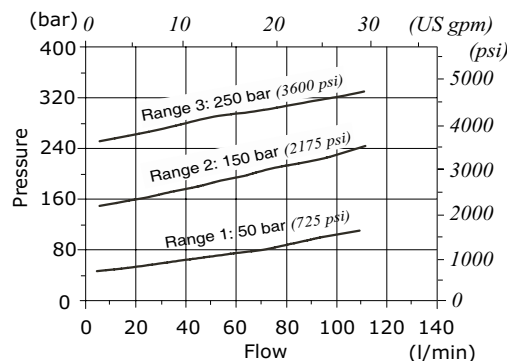



## MC10M type pressure relief valve - 2 way

- Direct acting
- Poppet type

Technical specifications and diagrams are measured with mineral oil of 46 cSt viscosity at 40°C (104°F) temperature.

### MC10M

Nominal flow		70 l/min (18.5 US gpm)
Max. pressure		260 bar (3770 psi)
Oil leakage	80% of max. pressure setting	4 cm <sup>3</sup> /min (0.24 in <sup>3</sup> /min)
Fluid		mineral based oil
Viscosity		10-200 cSt
Max level of contamination		20/18/14 ISO4406
Fluid temperature	with NBR seals with FPM seals	from -20°C (-4°F) to 80°C (176°F) from -20°C (-4°F) to 100°C (212°F)
Environmental temp. for working conditions		from -20°C (-4°F) to 50°C (122°F)
Cavity		SAE 10/2 A
Weight		0.18 kg (0.396 lb)

NOTE - For different conditions, please contact Walvoil Sales Dpt.

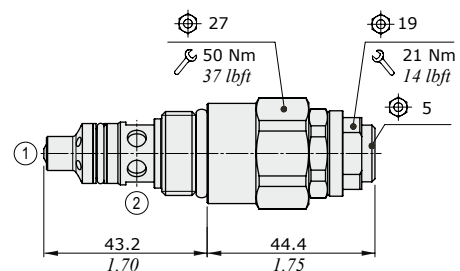
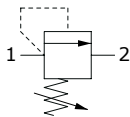

## Ordering codes and description composition

### MC10M/OY1B

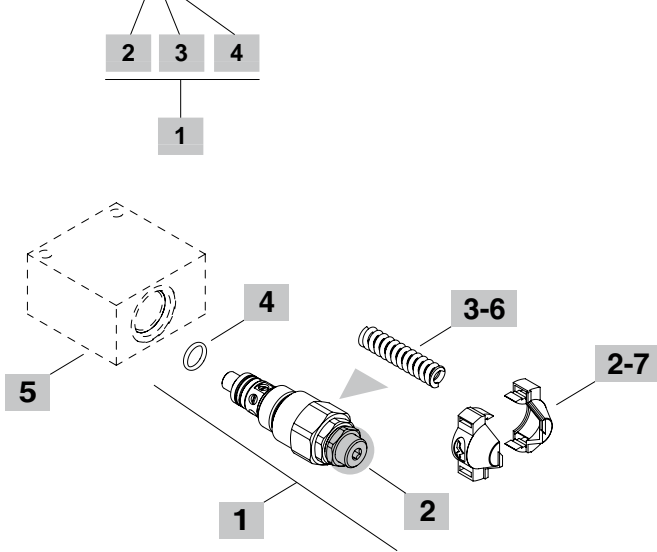

### 3 Pressure range

Standard setting is referred to 5 l/min (1.32 US gpm) flow

TYPE	DESCRIPTION
<b>1</b>	Pressure range 10÷60 bar (145÷870 psi); Std. setting 50 bar (725 psi)
<b>2</b>	Pressure range 40÷110 bar (580÷1595 psi); Std. setting 80 bar (1160 psi)
<b>3</b>	Pressure range 110÷220 bar (1595÷3190 psi); Std. setting 175 bar (2540 psi)
<b>4</b>	Pressure range 200÷260 bar (2900÷3770 psi); Std. setting 220 bar (3190 psi)

### 4 Seals

TYPE	DESCRIPTION
<b>B</b>	<b>NBR (Buna)</b> o-ring seals, std configuration
<b>V</b>	<b>FPM (Viton)</b> o-ring seals, contact Sales Dept.

### 5 Valve body

TYPE	CODE	DESCRIPTION
<b>SAE 10/2-G 3/8</b>	3CC1020C11	Aluminium body for cavity 10 valve, G 3/8 std thread

Note: aluminium body can stand up to 210 bar (3050 psi)  
For steel bodies or different threading see from page 215

### 1 Cartridges

TYPE	CODE	DESCRIPTION
<b>MC10M/OY1B</b>	0MC10002026	Pressure range <b>1</b>
<b>MC10M/OY2B</b>	0MC10002027	Pressure range <b>2</b>
<b>MC10M/OY3B</b>	0MC10002028	Pressure range <b>3</b>
<b>MC10M/OY4B</b>	0MC10002029	Pressure range <b>4</b>

### 2 Adjustments

TYPE	DESCRIPTION
<b>Y</b>	With screw
<b>X</b>	Valve set with antitampering cap (part code: see point <b>7</b> )

### 6 Springs

TYPE	CODE	DESCRIPTION
<b>1</b>	3ML1114500	Pressure range <b>1</b> - no band
<b>2</b>	3ML1114502	Pressure range <b>2</b> - blue band
<b>3</b>	3ML1114501	Pressure range <b>3</b> - red band
<b>4</b>	3ML1114503	Pressure range <b>4</b> - green band

### 7 Accessories

TYPE	CODE	DESCRIPTION
-	4COP126301	Antitampering cap (x2)

## Rating diagrams

**MC10M pressure vs. flow**  
Std. setting at 5 l/min (1.32 US gpm)

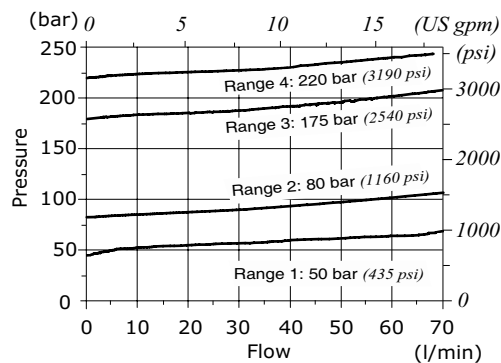



## MC..R type pressure relief valves - 2 way

- Direct acting
- Poppet type
- From SAE08 to SAE10 cavities

Technical specifications and diagrams are measured with mineral oil of 46 cSt viscosity at 40°C (104°F) temperature.

	MC08R	MC09R	MC10R
Nominal flow	25 l/min (6.6 US gpm)	35 l/min (9.2 US gpm)	50 l/min (13.2 US gpm)
Max. pressure		350 bar (5100 psi)	
Oil leakage	80% of max. pressure setting	2 cm <sup>3</sup> /min (0.122 in <sup>3</sup> /min)	
Fluid		mineral based oil	
Viscosity		10-200 cSt	
Max level of contamination		20/18/14 ISO4406	
Fluid temperature	with NBR seals with FPM seals	from -20°C (-4°F) to 80°C (176°F) from -20°C (-4°F) to 100°C (212°F)	
Environmental temp. for working conditions		from -20°C (-4°F) to 50°C (122°F)	
Cavity	SAE 08/2 A	SAE 9/2 A	SAE 10/2 A
Weight	0.170 kg (0.37 lb)	0.230 kg (0.51 lb)	0.315 kg (0.69 lb)

NOTE - For different conditions, please contact Walvoil Sales Dpt.

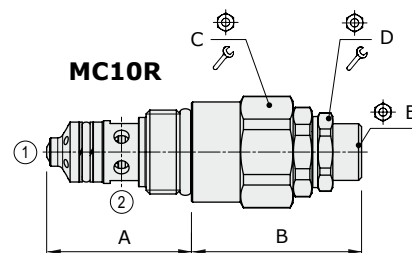
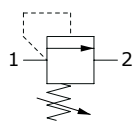

Valve type	A		B		C			D			
	mm	in	mm	in	mm	mm	mm	Nm	lbft		
MC08R	34	1.34	46.6	1.83	24	19	5	30	22	25	18
MC09R	33.8	1.33	46.6	1.83	24	19	5	42	31	25	18
MC10R	38.3	1.50	44.4	1.75	27	19	5	50	37	25	18

## Ordering codes and description composition

### MC08R/OY1B

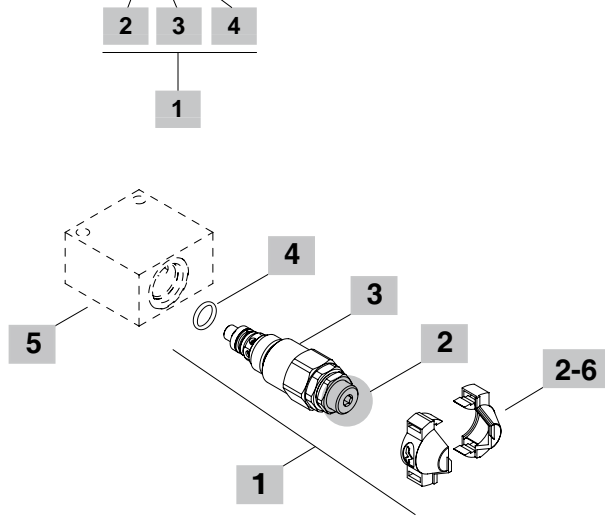

### 2 Adjustments

TYPE	DESCRIPTION
<b>Y</b>	With screw
<b>X</b>	Valve set with antitampering cap (part code: see point <b>6</b> )

### 3 Pressure range

Standard setting is referred to 5 l/min (1.32 US gpm) flow

TYPE	DESCRIPTION
<b>1</b>	Pressure range 10÷120 bar (145÷1740 psi); Std. setting 80 bar (1160 psi)
<b>2</b>	Pressure range 40÷200 bar (580÷2900 psi); Std. setting 175 bar (2540 psi)
<b>3</b>	Pressure range 200÷350 bar (2900÷5100 psi); Std. setting 250 bar (3600 psi)

### 4 Seals

TYPE	DESCRIPTION
<b>B</b>	<b>NBR (Buna)</b> o-ring seals, std configuration
<b>V</b>	<b>FPM (Viton)</b> o-ring seals, contact Sales Dept.

### 5 Valve body

TYPE	CODE	DESCRIPTION
<b>SAE 08/2-G 3/8</b>	3CC0820C11	Aluminium body for cavity 08 valve, G 3/8 std thread
<b>SAE 09/2-G 3/8</b>	3CC0920C11	Aluminium body for cavity 09 valve, G 3/8 std thread
<b>SAE 10/2-G 3/8</b>	3CC1020C11	Aluminium body for cavity 10 valve, G 3/8 std thread

Note: aluminium body can stand up to 210 bar (3050 psi)  
For steel bodies or different threading see from page 215

### 6 Accessories

TYPE	CODE	DESCRIPTION
-	4COP126301	Antitampering cap (X2)

### 1 Cartridges

TYPE	CODE	DESCRIPTION
<b>SAE cavity 08/2 A</b>		
<b>MC08R/OY1B</b>	0MC08002050	Pressure range <b>1</b>
<b>MC08R/OY2B</b>	0MC08002051	Pressure range <b>2</b>
<b>MC08R/OY3B</b>	0MC08002052	Pressure range <b>3</b>
<b>SAE cavity 09/2 A</b>		
<b>MC09R/OY1B</b>	0MC09002000	Pressure range <b>1</b>
<b>MC09R/OY2B</b>	0MC09002001	Pressure range <b>2</b>
<b>MC09R/OY3B</b>	0MC09002002	Pressure range <b>3</b>
<b>SAE cavity 10/2 A</b>		
<b>MC10R/OY1B</b>	0MC10002023	Pressure range <b>1</b>
<b>MC10R/OY2B</b>	0MC10002024	Pressure range <b>2</b>
<b>MC10R/OY3B</b>	0MC10002025	Pressure range <b>3</b>

## Rating diagrams

### MC08R pressure vs. flow

Std. setting at 5 l/min (1.32 US gpm)

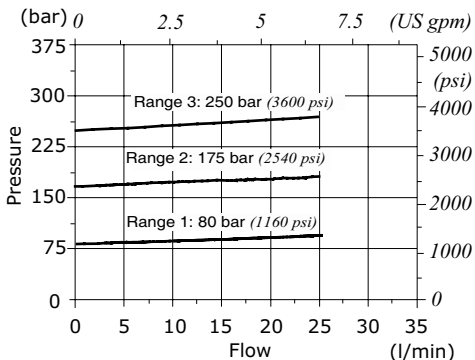

### MC09R pressure vs. flow

Std. setting at 5 l/min (1.32 US gpm)

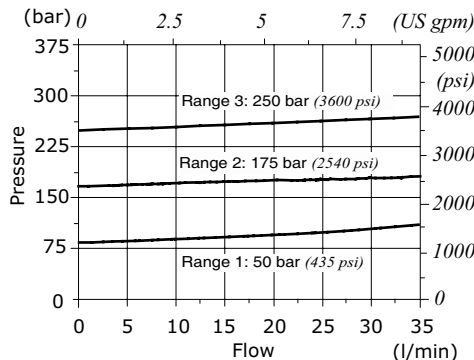

### MC10R pressure vs. flow

Std. setting at 5 l/min (1.32 US gpm)

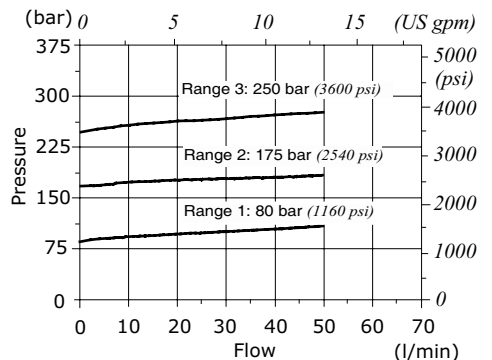





## MC08Y type pressure relief valve - 2 way

- Solenoid proportional type, direct acting
- Increasing pressure with increasing current (NO)
- Poppet type

Technical specifications and diagrams are measured with mineral oil of 46 cSt viscosity at 40°C (104°F) temperature.

MC08Y		
Nominal flow		0.5 l/min (0.15 US gpm)
Max. flow		1 l/min (0.3 US gpm)
Max. pressure		350 bar (5100 psi)
Oil leakage	80% of max. pressure setting	2 cm <sup>3</sup> /min (0.122 in <sup>3</sup> /min)
Fluid		mineral based oil
Viscosity		10-200 cSt
Max level of contamination		18/16/13 ISO4406
Fluid temperature	with NBR seals with FPM seals	from -20°C (-4°F) to 80°C (176°F) from -20°C (-4°F) to 100°C (212°F)
Environmental temp. for working conditions		from -40°C (-40°F) to 100°C (212°F)
Cavity		SAE 08/2
Coil type*		MP35
Nominal voltages		12 VDC - 24V DC
Power rating		11.2 W (12 VDC) - 11.4 W (24 VDC)
Max control current		12 V -> 1.1 A - 24 V -> 0.68 A
Dither frequency		150 Hz
Hysteresis		≤5%
Weight		0.55 kg (1.212 lb)

NOTE - For different conditions, please contact Walvoil Sales Dpt. - For coils further features see from page 206.

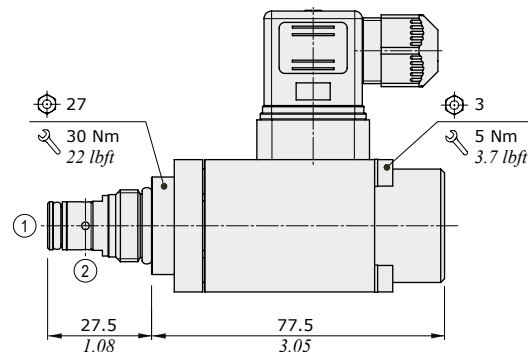
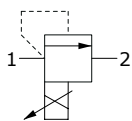

## Ordering codes and description composition

### MC08Y/021B

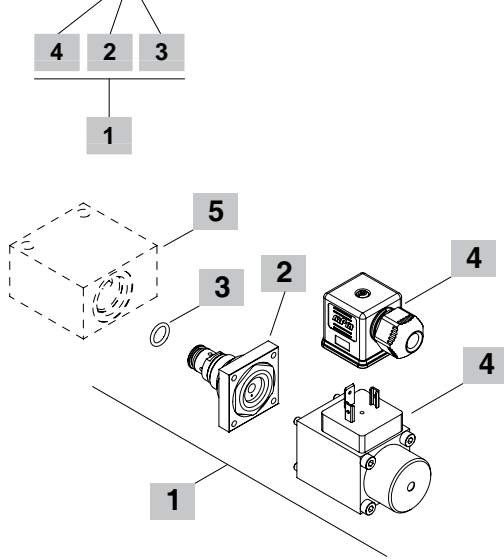

### 2 Pressure range

TYPE	DESCRIPTION
<b>1</b>	Pressure range 10÷100 bar (145÷1450 psi)
<b>2</b>	Pressure range 50÷200 bar (725÷2900 psi)
<b>3</b>	Pressure range 80÷350 bar (1160÷5100 psi)
<b>4</b>	Pressure range 5÷40 bar (72.5÷580 psi)

### 3 Seals

TYPE	DESCRIPTION
<b>B</b>	<b>NBR (Buna)</b> o-ring seals, std configuration
<b>V</b>	<b>FPM (Viton)</b> o-ring seals, contact Sales Dept.

### 4 Coils and connectors

TYPE	CODE	DESCRIPTION
<b>2) MP35 12VDC</b>	5SL4000120	12VDC-ISO4400 coil
<b>ISO4400</b>	4CN1009995	Connector
<b>4) MP35 24VDC</b>	4SL4000240	24VDC-ISO4400 coil
<b>ISO4400</b>	4CN1009995	Connector

For complete coils and connectors list see from page 206

### 5 Valve body

TYPE	CODE	DESCRIPTION
<b>SAE 08/2-G 1/4</b>	3CC0820B11	Aluminium body for cavity 08 valve, G 1/4 std thread

Note: aluminium body can stand up to 210 bar (3050 psi)  
For steel bodies or different threading see from page 215

### 1 Cartridges

TYPE	CODE	DESCRIPTION
<b>MC08Y/021B</b>	0MC08002013	Pressure range <b>1</b> , 12VDC
<b>MC08Y/022B</b>	0MC08002010	Pressure range <b>2</b> , 12VDC
<b>MC08Y/023B</b>	0MC08002011	Pressure range <b>3</b> , 12VDC
<b>MC08Y/024B</b>	0MC08002022	Pressure range <b>4</b> , 12VDC

## Rating diagrams

Pressure setting vs. % max. control current  
at 0.5 l/min (0.13 US gpm)

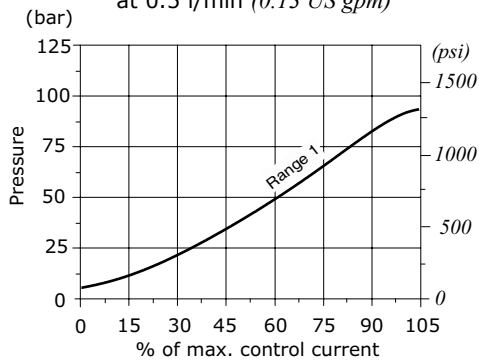

Pressure setting vs. % max. control current  
at 0.5 l/min (0.13 US gpm)

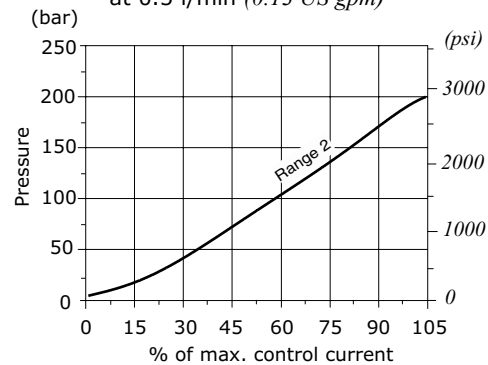

Pressure setting vs. % max. control current  
at 0.5 l/min (0.13 US gpm)

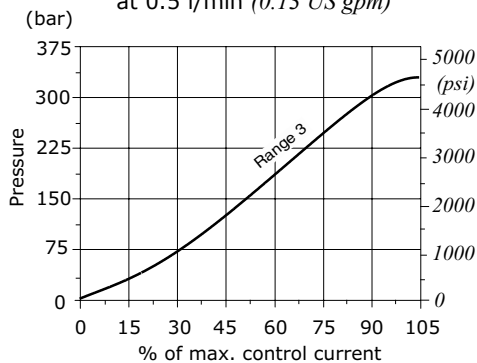

Pressure setting vs. % max. control current  
at 0.5 l/min (0.13 US gpm)

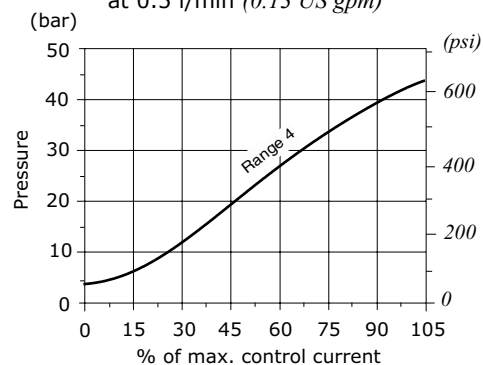



## MC10T - MC10T-HF type pressure relief valve - 2 way

- Solenoid proportional type, direct acting
- Decreasing pressure with increasing current (NC)
- Poppet type

Technical specifications and diagrams are measured with mineral oil of 46 cSt viscosity at 40°C (104°F) temperature.

		MC10T	MC10T-HF
Max. flow		3 l/min (0.79 US gpm)	10 l/min (2.64 US gpm)
Max. pressure		350 bar (5100 psi)	250 bar (3600 psi)
Oil leakage	80% of max. pressure setting	0.25 cm <sup>3</sup> /min (0.015 in <sup>3</sup> /min)	0.50 cm <sup>3</sup> /min (0.030 in <sup>3</sup> /min)
Fluid		mineral based oil	
Viscosity		10-200 cSt	
Max level of contamination		18/16/13 ISO4406	
Fluid temperature	with NBR seals with FPM seals	from -20°C (-4°F) to 80°C (176°F) from -20°C (-4°F) to 100°C (212°F)	
Environmental temp. for working conditions		from -40°C (-40°F) to 100°C (212°F)	
Cavity		SAE 10/2	
Coil type*		BH or BQP19	BQP19
Nominal voltages		12 VDC - 24VDC	
Power rating		20.4 W (BH) - 15 W (BQP19)	15 W
Max control current		1 2V -> 1.70 A - 24 V -> 0.85 A (BH) 12 V-> 1.25 A - 24 V -> 0.63 A (BQP19)	12 V -> 1.25 A - 24 V -> 0.63 A
Dither frequency		150 Hz	
Hysteresis		<5%	
Weight		0.54 kg (1.19 lb)	0.87 kg (1.91 lb)

NOTE - For different conditions, please contact Walvoil Sales Dpt. - For coils further features see from page 206.

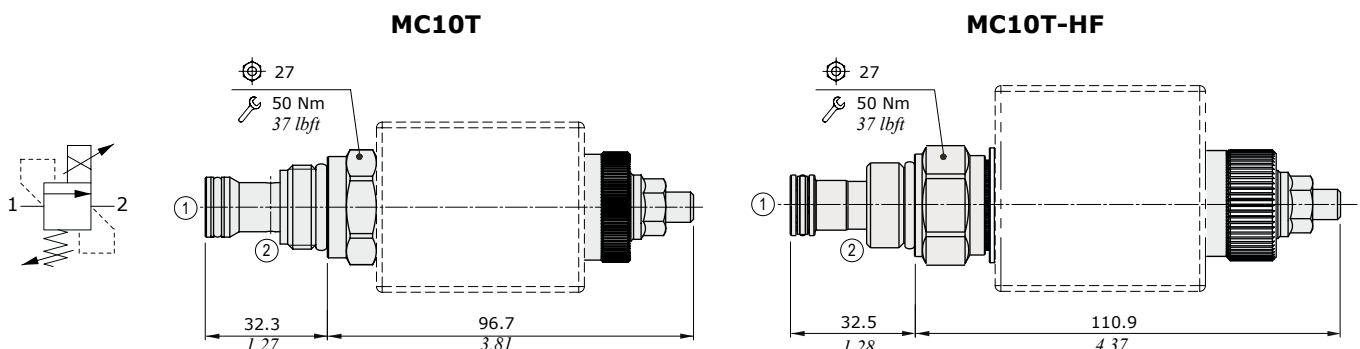

## Ordering codes and description composition

### MC10T/001B

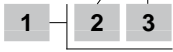

### MC10T/031B

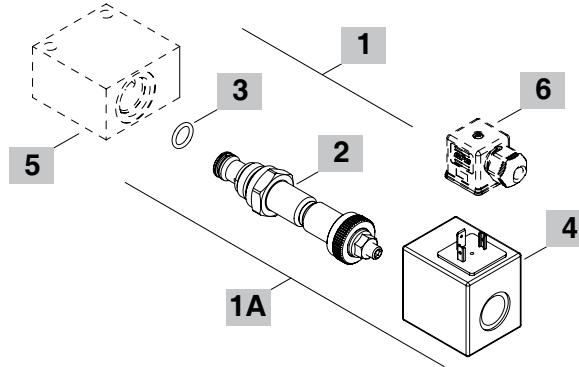

#### 1 Cartridges

TYPE	CODE	DESCRIPTION
<b>MC10T/001B</b>	OMC10002047	Pressure range <b>1</b>
<b>MC10T/002B</b>	OMC10002048	Pressure range <b>2</b>
<b>MC10T/003B</b>	OMC10002049	Pressure range <b>3</b>
<b>MC10T-HF/003B</b>	OMC10002068	Pressure range <b>3</b>

#### 1A Complete cartridges with coil

TYPE	CODE	DESCRIPTION
<b>MC10T/031B</b>	OMC10002019	Pressure range <b>1</b> , 12VDC
<b>MC10T/032B</b>	OMC10002020	Pressure range <b>2</b> , 12VDC
<b>MC10T/033B</b>	OMC10002021	Pressure range <b>3</b> , 12VDC

#### 2 Pressure range

TYPE	DESCRIPTION
<b>MC10T</b>	
<b>1</b>	Pressure range 15÷130 bar (217÷1885 psi)
<b>2</b>	Pressure range 15÷170 bar (217÷2465 psi)
<b>3</b>	Pressure range 15÷210 bar (217÷3045 psi)
<b>MC10T-HF</b>	
<b>3</b>	Pressure range 20÷225 bar (290÷3260 psi)

Note: for further pressure range contact Sales Dept.

#### 3 Seals

TYPE	DESCRIPTION
<b>B</b>	<b>NBR (Buna)</b> o-ring seals, std configuration
<b>V</b>	<b>FPM (Viton)</b> o-ring seals, contact Sales Dept.

#### 4 Coils

TYPE	CODE	DESCRIPTION
<b>2) BH 12VDC</b>	4SLD001200	12VDC-ISO4400 coil
<b>3) BQP19 12VDC</b>	4SL5000126	12VDC-ISO4400 coil
<b>4) BH 24VDC</b>	4SLD002400	24VDC-ISO4400 coil
<b>5) BQP19 24VDC</b>	4SL5000245	24VDC-ISO4400 coil

Note: for HF version use only BQP19 coil  
For complete coils list see from page 206

#### 5 Valve body

TYPE	CODE	DESCRIPTION
<b>SAE 10/2-G 3/8</b>	3CC1020C11	Aluminium body for cavity 10 valve, G 3/8 std thread

Note: aluminium body can stand up to 210 bar (3050 psi)  
For steel bodies or different threading see from page 215

#### 6 Connector

TYPE	CODE	DESCRIPTION
<b>ISO4400</b>	4CN1009995	Connector

For complete connectors list see from page 206

**MC10T pressure setting vs. % max. control current**  
at 1 l/min (0.26 US gpm)

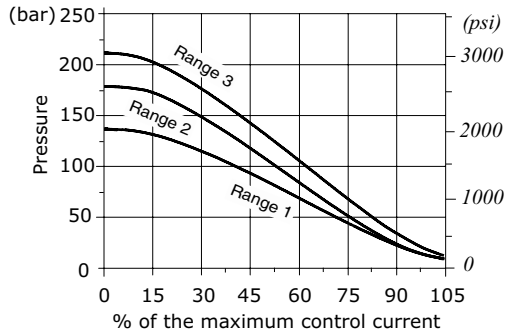

**MC10T-HF pressure setting vs. % max. control current**  
at 2 l/min (0.53 US gpm)

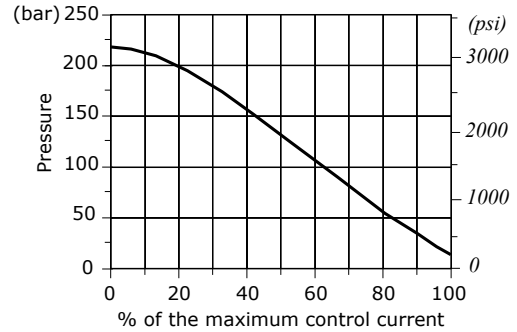

**MC10T pressure vs. flow 1->2**  
for % of control current - Pressure range 1 -

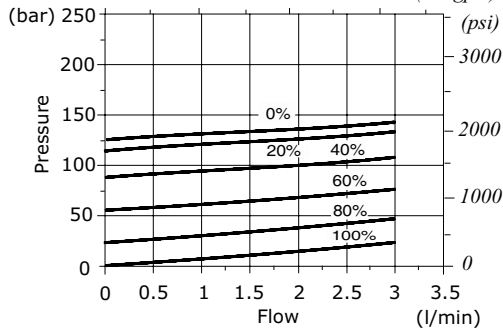

**MC10T-HF pressure vs. flow 1->2**  
for % of control current

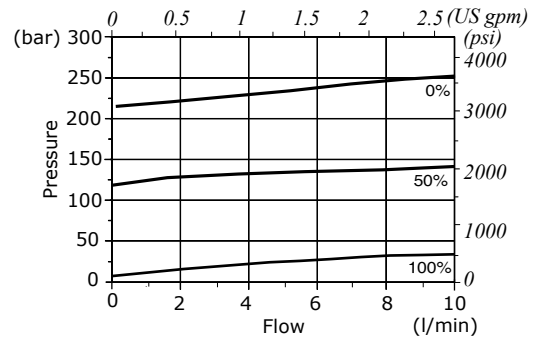

**MC10T pressure vs. flow 1->2**  
for % of control current - Pressure range 2 -

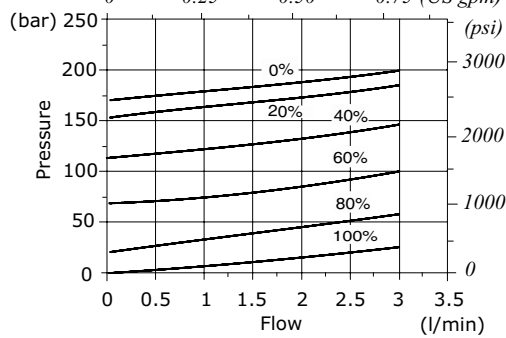

**MC10T pressure vs. flow 1->2**  
for % of control current - Pressure range 3 -

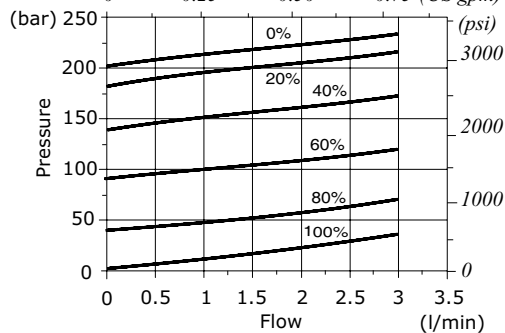





## MC10X - MC10X-HF type pressure relief valve - 2 way

- Solenoid proportional type, direct acting
- Poppet type

Technical specifications and diagrams are measured with mineral oil of 46 cSt viscosity at 40°C (104°F) temperature.

		MC10X	MC10X-HF
Max. flow		3 l/min (0.79 US gpm)	10 l/min (2.64 US gpm)
Max. pressure		350 bar (5100 psi)	250 bar (3600 psi)
Oil leakage	80% of max. pressure setting	0.25 cm <sup>3</sup> /min (0.015 in <sup>3</sup> /min)	0.5 cm <sup>3</sup> /min (0.030 in <sup>3</sup> /min)
Fluid		mineral based oil	
Viscosity		10-200 cSt	
Max level of contamination		18/16/13 ISO4406	
Fluid temperature	with NBR seals with FPM seals	from -20°C (-4°F) to 80°C (176°F) from -20°C (-4°F) to 100°C (212°F)	
Environmental temp. for working conditions		from -40°C (-40°F) to 100°C (212°F)	
Cavity		SAE 10/2	
Coil type*		BH or BQP19	BQP19
Nominal voltages		12 VDC - 24 VDC	
Power rating		20.4 W (BH) - 15 W (BQP19)	15 W
Max. control current		12 V -> 1.70 A - 24 V -> 0.85 A (BH) 12 V -> 1.25 A - 24 V -> 0.63 A (BQP19)	12 V -> 1.25 A - 24 V -> 0.63 A
Dither frequency		150 Hz	
Hysteresis		<5%	
Weight		0.760 kg (1.67 lb)	0.863 kg (1.90 lb)

NOTE - For different conditions, please contact Walvoil Sales Dpt. - For coils further features see from page 206.

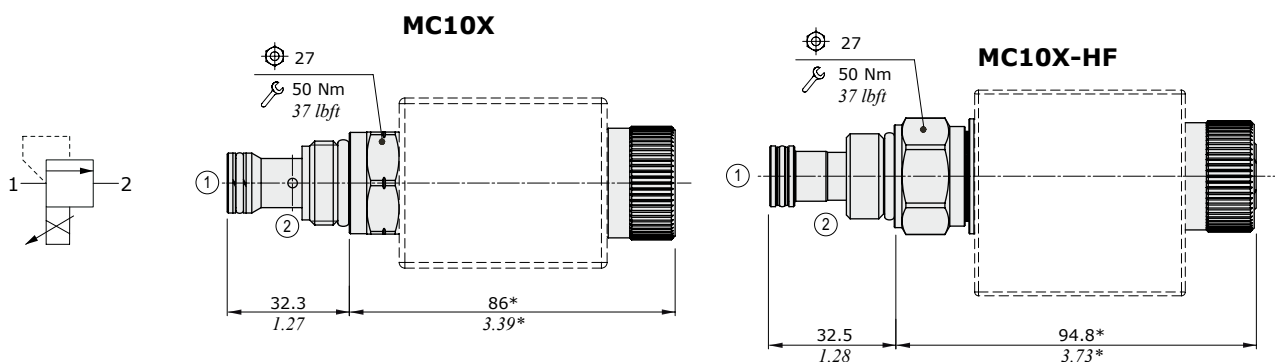

NOTE (\*): dimension for configuration without override, for dimensions with different type of emergency see page 213.

## Ordering codes and description composition

### MC10X/001B

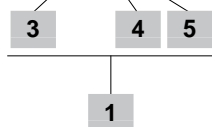

### MC10X/031B

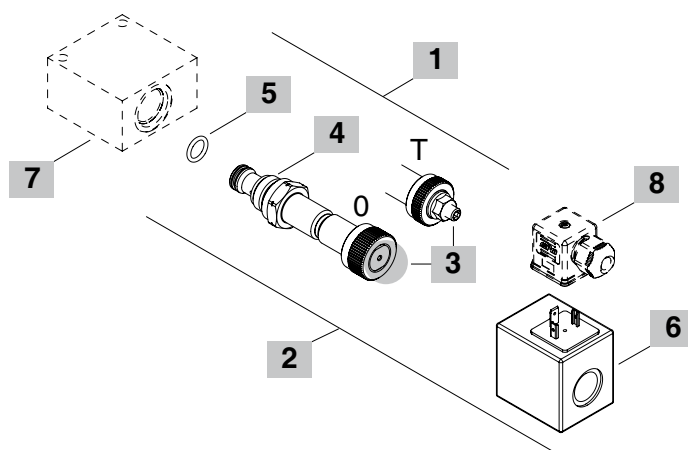
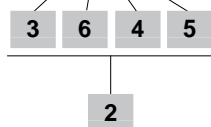

### 1 Cartridges

TYPE	CODE	DESCRIPTION
<b>MC10X/001B</b>	0MC10002050	Pressure range <b>1</b>
<b>MC10X/002B</b>	0MC10002051	Pressure range <b>2</b>
<b>MC10X/003B</b>	0MC10002052	Pressure range <b>3</b>

### 2 Complete cartridges with coil

TYPE	CODE	DESCRIPTION
<i>Note: not for MC10X-HF</i>		
<b>MC10X/031B</b>	0MC10002039	Pressure range <b>1</b> , 12VDC
<b>MC10X/032B</b>	0MC10002040	Pressure range <b>2</b> , 12VDC
<b>MC10X/033B</b>	0MC10002041	Pressure range <b>3</b> , 12VDC
<b>MC10X-HF/033B</b>	0MC10002064	Pressure range <b>3</b> , 12VDC
<b>MC10X-HF/T33B</b>	0MC10002089	Pressure range <b>3</b> , 12VDC

### 3 Emergency

TYPE	DESCRIPTION
<b>0</b>	Without override
<b>T</b>	With screw

### 4 Pressure range

TYPE	DESCRIPTION
<b>MC10X</b>	
<b>1</b>	Pressure range 7÷120 bar (102÷1740 psi)
<b>2</b>	Pressure range 7÷170 bar (102÷2450 psi)
<b>3</b>	Pressure range 7÷210 bar (102÷3050 psi)

### MC10X-HF

<b>3</b>	Pressure range 3÷230 bar (43÷3330 psi)
----------	--

Note: for further pressure range contact Sales Dept.

### 5 Seals

TYPE	DESCRIPTION
<b>B</b>	<b>NBR (Buna)</b> o-ring seals, std configuration
<b>V</b>	<b>FPM (Viton)</b> o-ring seals, contact Sales Dept.

### 6 Coil

TYPE	CODE	DESCRIPTION
<b>2) BH 12VDC</b>	4SLD001200	12VDC-ISO4400 coil
<b>3) BQP19 12VDC</b>	4SL5000126	12VDC-ISO4400 coil
<b>4) BH 24VDC</b>	4SLD002400	24VDC-ISO4400 coil
<b>5) BQP19 24VDC</b>	4SL5000245	24VDC-ISO4400 coil

Note: for HF version use only BQP19 coil  
For complete coils list see from page 206

### 7 Valve body

TYPE	CODE	DESCRIPTION
<b>SAE 10/2-G 3/8</b>	3CC1020C11	Aluminium body for cavity 10 valve, G 3/8 std thread

Note: aluminium body can stand up to 210 bar (3050 psi)  
For steel bodies or different threading see from page 215

### 8 Connector

TYPE	CODE	DESCRIPTION
<b>ISO4400</b>	4CN1009995	Connector

For complete connectors list see from page 206



**MC10X pressure setting vs. % max. control current**  
at 1 l/min (0.26 US gpm)

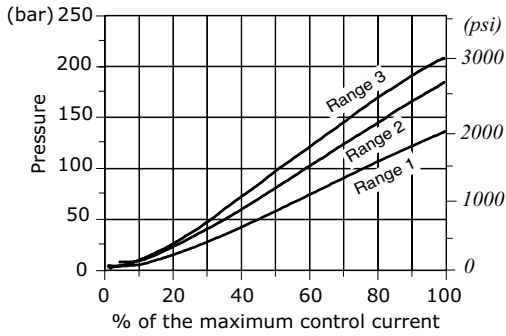

**MC10X-HF pressure setting vs. % max. control current**  
at 2 l/min (0.53 US gpm)

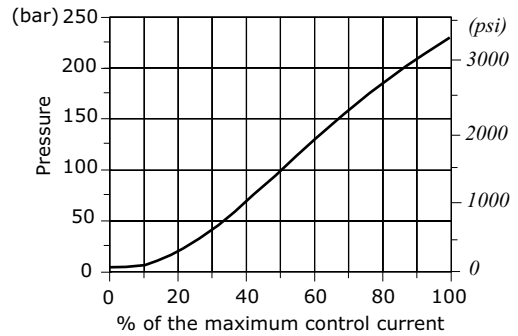

**MC10X pressure vs. flow 1->2**  
for % of control current - Pressure range 1 -

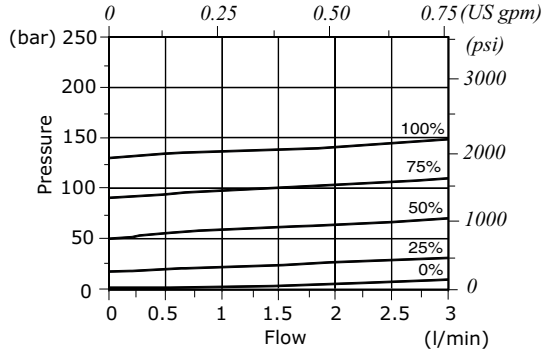

**MC10X-HF pressure vs. flow 1->2**  
for % of control current

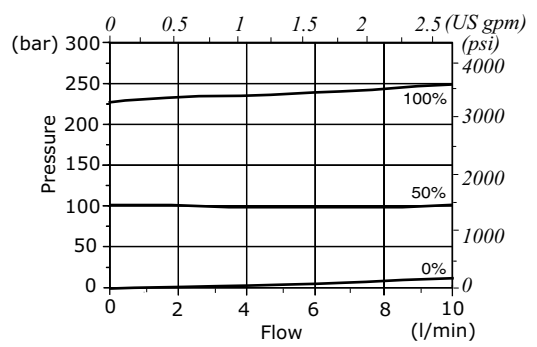

**MC10X pressure vs. flow 1->2**  
for % of control current - Pressure range 2 -

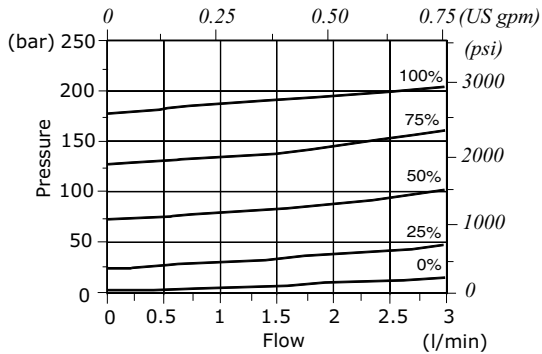

**MC10X pressure vs. flow 1->2**  
for % of control current - Pressure range 3 -

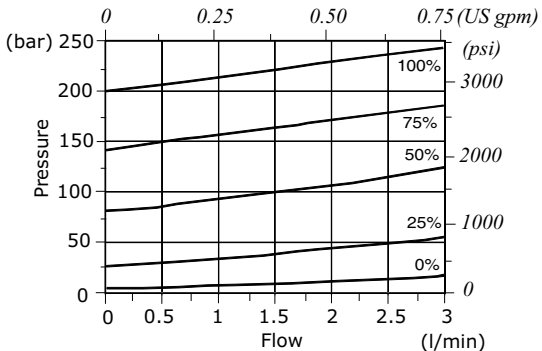





## MD..M type shockless pressure relief valve - 2 way

- Direct acting
- Poppet type
- From SAE10 to SAE12 cavities

Technical specifications and diagrams are measured with mineral oil of 46 cSt viscosity at 40°C (104°F) temperature.

		MD10M	MD12M
Nominal flow		60 l/min (15.8 US gpm)	100 l/min (26.4 US gpm)
Max. pressure		350 bar (5100 psi)	
Oil leakage	at 80% of max. pressure setting	5 cm <sup>3</sup> /min (0.3 in <sup>3</sup> /min)	5 cm <sup>3</sup> /min (0.3 in <sup>3</sup> /min)
Fluid		mineral based oil	
Viscosity		10-200 cSt	
Max level of contamination		20/18/14 ISO4406	
Fluid temperature	with NBR seals	from -20°C (-4°F) to 80°C (176°F)	
Environmental temp. for working conditions		from -20°C (-4°F) to 50°C (122°F)	
Cavity		SAE 10/2	SAE 12/2
Weight		0.200 kg (0.44 lb)	0.355 kg (0.78 lb)

NOTE - For different conditions, please contact Walvoil Sales Dpt.

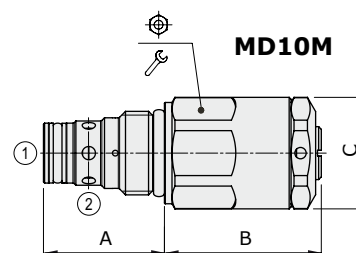
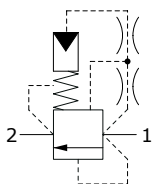

Valve type	A		B		C		⊕	⌘	Nm	lbft
	mm	in	mm	in	mm	in				
MD10M	32	1.25	73.5	2.89	ø29.5	ø1.16	27	50	37	
MD12M	46	1.81	92.5	3.64	ø35	ø1.38	32	80	59	

### Ordering codes and description composition

#### MD10M/313B

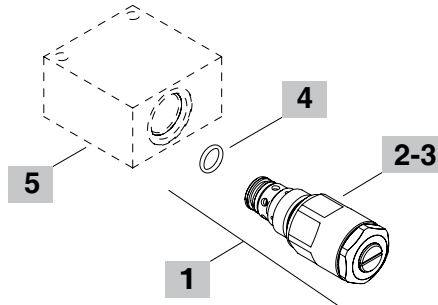
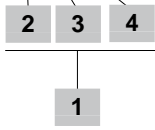

#### 1 Cartridges

TYPE	CODE	DESCRIPTION
<b>SAE cavity 10/2</b>		
MD10M/313B	OMD10002027	Pressure range 13
<b>SAE cavity 12/2</b>		
MD12M/513B	OMD12002004	Pressure range 13

#### 2 Reaction time

TYPE	DESCRIPTION
2	Reaction time 0.2 sec. (± 0.1 sec.)
3	Reaction time 0.3 sec. (± 0.1 sec.)
4	Reaction time 0.4 sec. (± 0.1 sec.)
5	Reaction time 0.5 sec. (± 0.1 sec.)
6	Reaction time 0.6 sec. (± 0.1 sec.)
7	Reaction time 0.7 sec. (± 0.1 sec.)

#### 3 Pressure range

TYPE	DESCRIPTION
<b>SAE cavity 10/2</b>	
11	Pressure range 130÷200 bar (1900÷2900 psi). Pressure ratio 1.9
12	Pressure range 180÷240 bar (2610÷3480 psi). Pressure ratio 2.2
13	Pressure range 220÷290 bar (3190÷4200 psi), Setting 250 bar (3625 psi) at 25 l/min (6.6 US gpm). Pressure ratio 2.4
21	Pressure range 170÷270 bar (2465÷3915 psi). Pressure ratio 2.5
22	Pressure range 220÷290 bar (3190÷4200 psi). Pressure ratio 2.8
<b>SAE cavity 12/2</b>	
11	Pressure range 125÷155 bar (1810÷2250 psi). Pressure ratio 1.7
12	Pressure range 160÷190 bar (2320÷2760 psi). Pressure ratio 1.9
13	Pressure range 180÷240 bar (2610÷3480 psi), Setting 220 bar (3190 psi) at 60 l/min (16 US gpm). Pressure ratio 2.2
21	Pressure range 150÷185 bar (1900÷2685 psi). Pressure ratio 2
22	Pressure range 190÷235 bar (2760÷3400 psi). Pressure ratio 2.35
23	Pressure range 230÷275 bar (3335÷3990 psi). Pressure ratio 2.55

Note: supplied valves are set at the requested pressure and sealed

#### 4 Seals

TYPE	DESCRIPTION
B	<b>NBR (Buna)</b> o-ring seals, std configuration

#### 5 Valve body

TYPE	CODE	DESCRIPTION
<b>SAE 10/2-G 3/8</b>	3CC1020C11	Aluminium body for cavity 10 valve, G 3/8 std thread
<b>SAE 12/2-G 1/2</b>	3CC1220D11	Aluminium body for cavity 12 valve, G 1/2 std thread

Note: aluminium body can stand up to 210 bar (3050 psi)  
For steel bodies or different threading see from page 215

**MD10M performance curve example with typical dimensions**

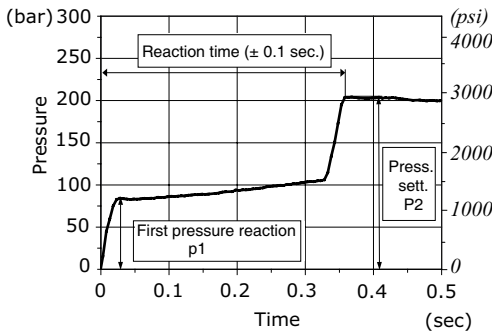

Pressure ratio:  $R_p = \frac{p_2}{p_1}$

First pressure reaction:  $p_1 = \frac{p_2}{R_p}$

**MD10M pressure vs. flow at max. and min. setting**

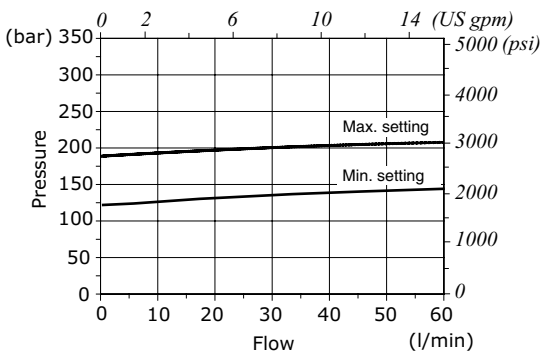

**Pressure range 11**  
130 ÷ 200 bar  
(1900 ÷ 2900 psi)  
Pressure ratio 1.9  
Q=60l/min  
(15.8 US gpm)

**MD10M performance curve at max. and min. setting**

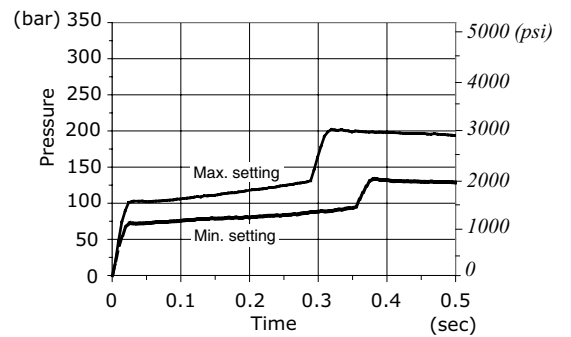

**MD10M pressure vs. flow at max. and min. setting**

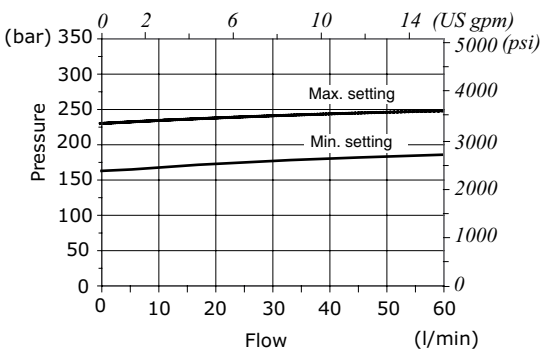

**Pressure range 12**  
180 ÷ 240 bar  
(2610 ÷ 3480 psi)  
Pressure ratio 2.2  
Q=60l/min  
(15.8 US gpm)

**MD10M performance curve at max. and min. setting**

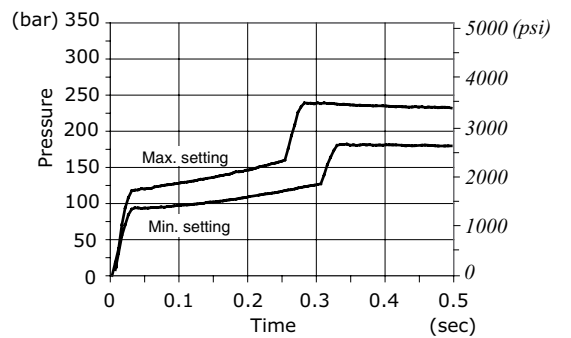

**MD10M pressure vs. flow at max. and min. setting**

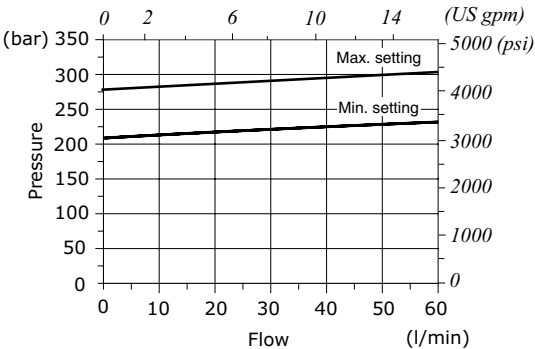

**Pressure range 13**  
220 ÷ 290 bar  
(3190 ÷ 4200 psi)  
Setting 250 bar (3625 psi) at 25 l/min  
(6.6 US gpm)  
Pressure ratio 2.4  
Q=60l/min  
(15.8 US gpm)

**MD10M performance curve at max. and min. setting**

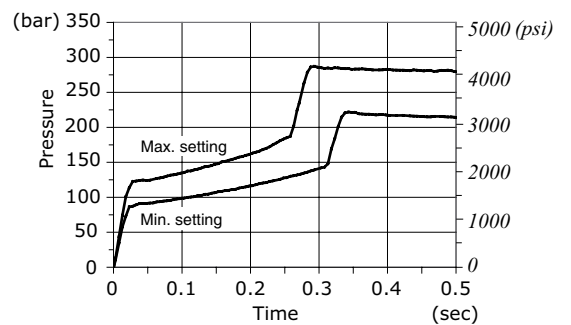

**Rating diagrams**

**MD10M pressure vs. flow**  
at max. and min. setting

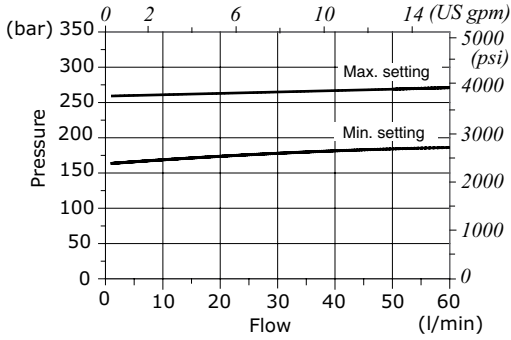

**Pressure range 21**  
170÷270 bar  
(2465÷3915 psi)  
Pressure ratio 2.5  
Q=60l/min  
(15.8 US gpm)

**MD10M performance curve**  
at max. and min. setting

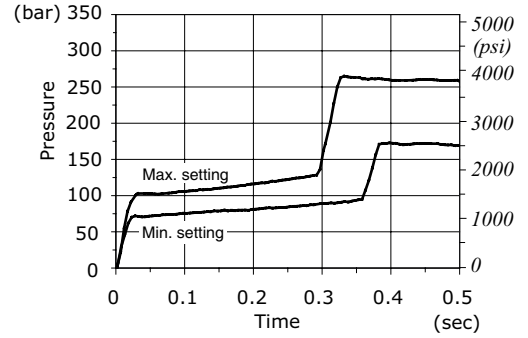

**MD10M pressure vs. flow**  
at max. and min. setting

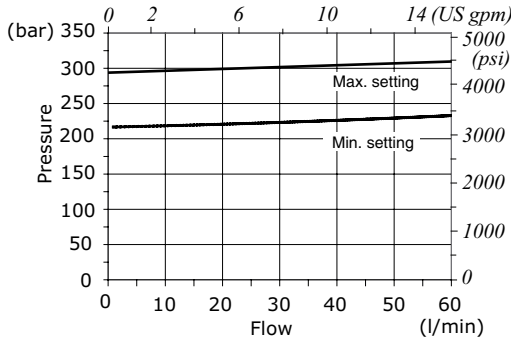

**Pressure range 22**  
220÷290 bar  
(3190÷4200 psi)  
Pressure ratio 2.8  
Q=60l/min  
(15.8 US gpm)

**MD10M performance curve**  
at max. and min. setting

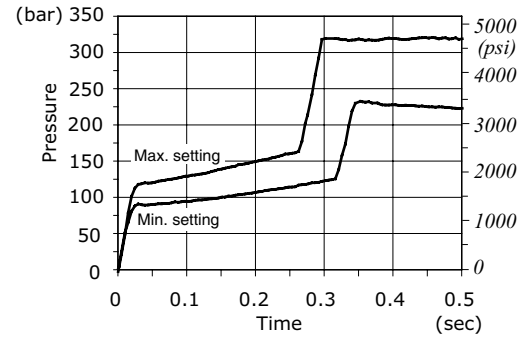

**MD12M performance curve example with typical dimensions**

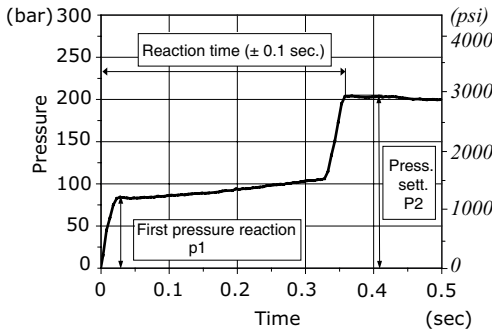

Pressure ratio:  $Rp = \frac{p2}{p1}$

First pressure reaction:  $p1 = \frac{p2}{Rp}$

**MD12M pressure vs. flow at max. and min. setting**

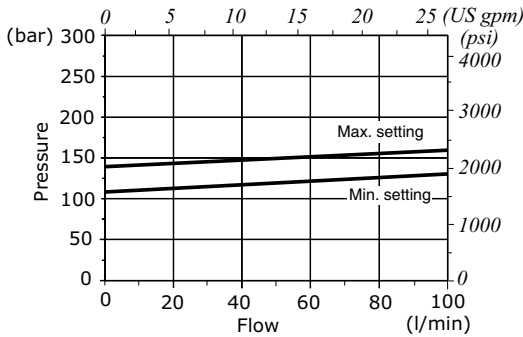

**Pressure range 11**  
125 ÷ 155 bar  
(1810 ÷ 2250 psi)  
Pressure ratio 1.7  
Q=100 l/min  
(26.4 US gpm)

**MD12M performance curve at max. and min. setting**

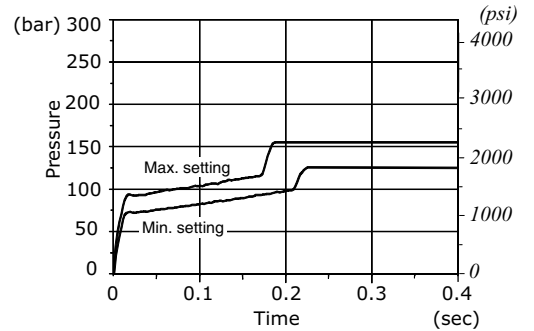

**MD12M pressure vs. flow at max. and min. setting**

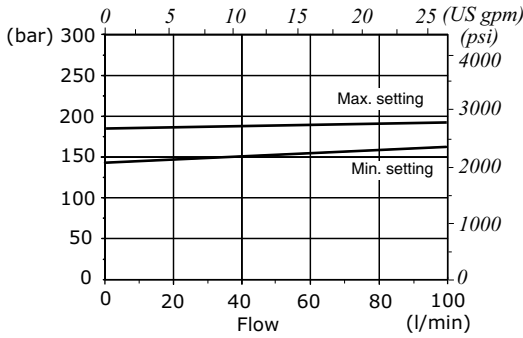

**Pressure range 12**  
160 ÷ 190 bar  
(2320 ÷ 2760 psi)  
Pressure ratio 1.9  
Q=100 l/min  
(26.4 US gpm)

**MD12M performance curve at max. and min. setting**

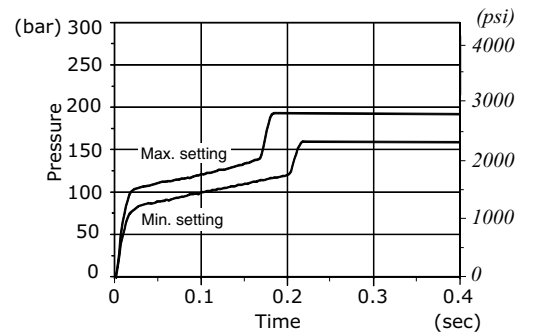

**MD12M pressure vs. flow at max. and min. setting**

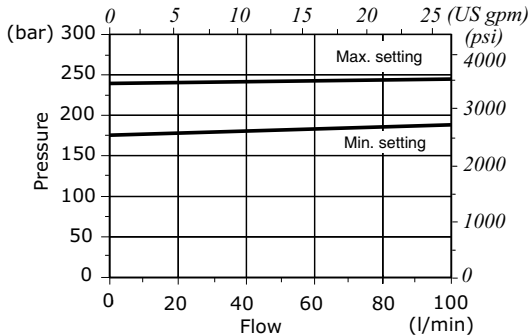

**Pressure range 13**  
180 ÷ 220 bar  
(2610 ÷ 3190 psi)  
Setting 220 bar (3190 psi) at 60 l/min  
(16 US gpm)  
Pressure ratio 2.2  
Q=100 l/min  
(26.4 US gpm)

**MD12M performance curve at max. and min. setting**

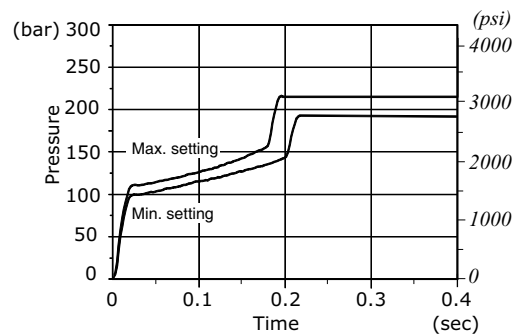

**Rating diagrams**

**MD12M pressure vs. flow**  
at max. and min. setting

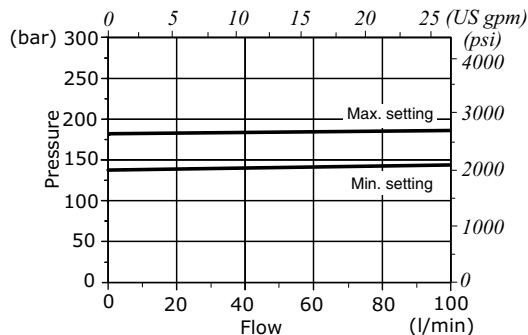

**Pressure range**  
**21**  
150÷185 bar  
(1900÷2685 psi)  
Pressure ratio 2  
Q=100 l/min  
(26.4 US gpm)

**MD12M performance curve**  
at max. and min. setting

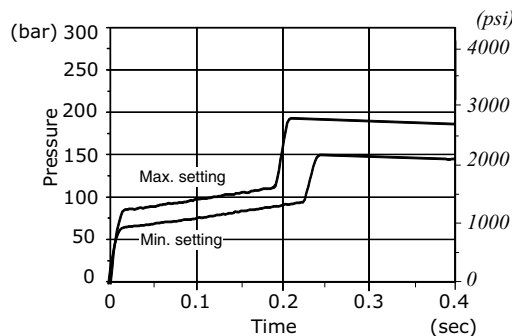

**MD12M pressure vs. flow**  
at max. and min. setting

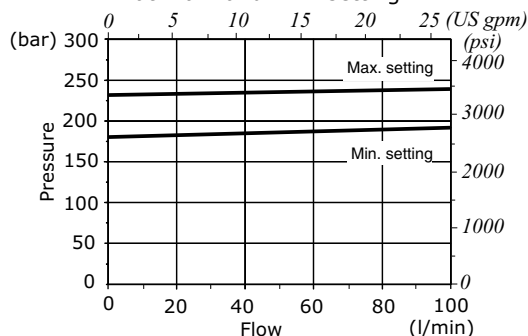

**Pressure range**  
**22**  
190÷235 bar  
(2760÷3400 psi)  
Pressure ratio 2.35  
Q=100 l/min  
(26.4 US gpm)

**MD12M performance curve**  
at max. and min. setting

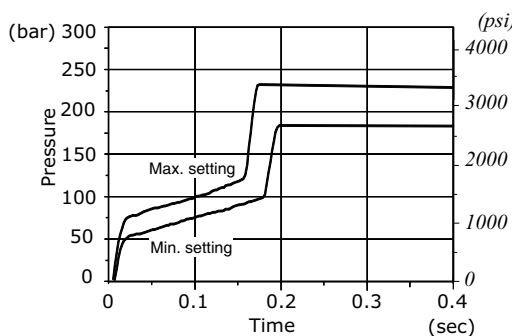

**MD12M pressure vs. flow**  
at max. and min. setting

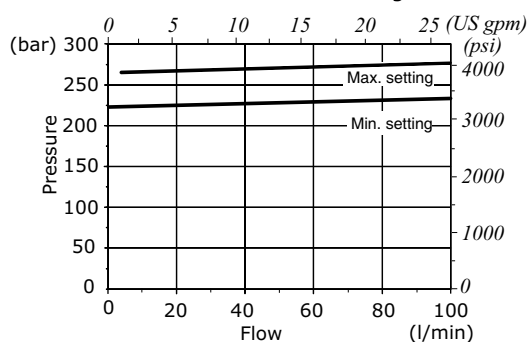

**Pressure range**  
**23**  
230÷275 bar  
(3335÷3990 psi)  
Pressure ratio 2.55  
Q=100 l/min  
(26.4 US gpm)

**MD12M performance curve**  
at max. and min. setting

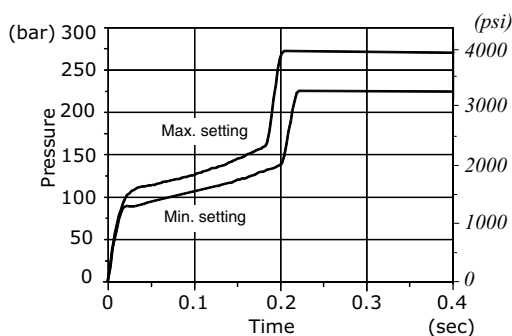





## MG..A type pressure relief valve - 2 way

- Differential operated
- Poppet type

Technical specifications and diagrams are measured with mineral oil of 46 cSt viscosity at 40°C (104°F) temperature.

	<b>MG10A</b>	<b>MG12A</b>
Nominal flow	60 l/min (15.8 US gpm)	100 l/min (26.4 US gpm)
Max. pressure	350 bar (5100 psi)	
Oil leakage	80% of max. pressure setting	2 cm <sup>3</sup> /min (0.122 in <sup>3</sup> /min)
Fluid	mineral based oil	
Viscosity	10-200 cSt	
Max level of contamination	20/18/14 ISO4406	
Fluid temperature	with NBR seals with FPM seals	from -20°C (-4°F) to 80°C (176°F) from -20°C (-4°F) to 100°C (212°F)
Environmental temp. for working conditions	from -20°C (-4°F) to 50°C (122°F)	
Cavity	SAE 10/2	SAE 12/2
Weight	0.34 kg (0.75 lb)	0.87 kg (1.92 lb)

NOTE - For different conditions, please contact Walvoil Sales Dpt.

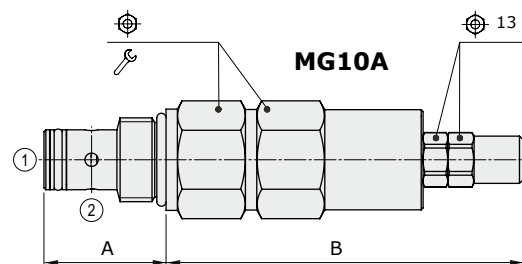
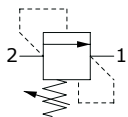

Valve type	A		B		⌀	⌘	
	mm	in	mm	in		Nm	lbft
<b>MG10A/OS</b>	32.3	1.27	94.5	3.72	27	50	37
<b>MG12A/OS</b>	46	1.81	126.5	4.98	36	80	59

For dimensions with different type of adjustment see page 213

## Ordering codes and description composition

### MG10A/0S1B

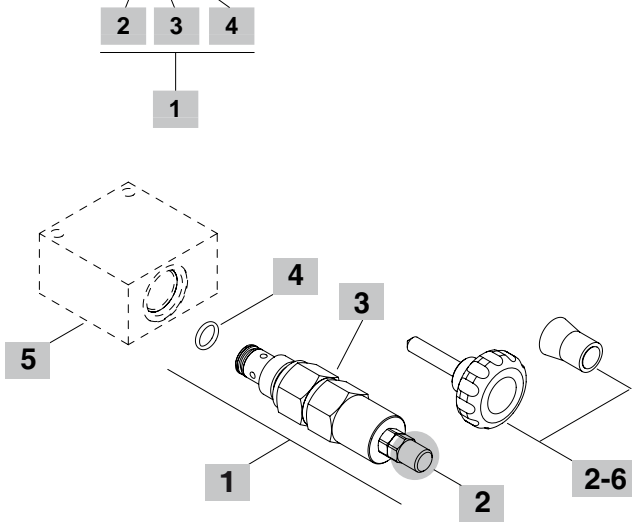

#### 1 Cartridges

TYPE	CODE	DESCRIPTION
<b>SAE cavity 10/2</b>		
<b>MG10A/0S1B</b>	OMG10002009	Pressure range <b>1</b>
<b>MG10A/0S2B</b>	OMG10002002	Pressure range <b>2</b>
<b>MG10A/0S3B</b>	OMG10002003	Pressure range <b>3</b>
<b>MG10A/0S4B</b>	OMG10002001	Pressure range <b>4</b>
<b>SAE cavity 12/2</b>		
<b>MG12A/0S1B</b>	OMG12002000	Pressure range <b>1</b>
<b>MG12A/0S2B</b>	OMG12002001	Pressure range <b>2</b>
<b>MG12A/0S3B</b>	OMG12002002	Pressure range <b>3</b>

#### 2 Adjustments

TYPE	DESCRIPTION
<b>S</b>	Screw with cap
<b>V</b>	With handwheel (part code: see point <b>6</b> )
<b>X</b>	Valve set with antitampering cap (part code: see point <b>6</b> )

#### 3 Pressure range

Standard setting is referred to 5 l/min (1.32 US gpm) flow

TYPE	DESCRIPTION
<b>1</b>	For SAE cavity 10/2: pressure range 30÷100 bar (435÷1450 psi); Std. setting 80 bar (1160 psi) For SAE cavity 12/2: pressure range 20÷100 bar (290÷1450 psi); Std. setting 50 bar (725 psi)
<b>2</b>	Pressure range 50÷200 bar (725÷2900 psi); Std. setting 150 bar (2175 psi)
<b>3</b>	Pressure range 150÷350 bar (2175÷5100 psi); Std. setting 250 bar (3625 psi)
<b>4</b>	Pressure range 5÷60 bar (72.5÷870 psi); Std. setting 30 bar (435 psi), only for SAE cavity 10/2

#### 4 Seals

TYPE	DESCRIPTION
<b>B</b>	<b>NBR (Buna)</b> o-ring seals, std configuration
<b>V</b>	<b>FPM (Viton)</b> o-ring seals, contact Sales Dept.

#### 5 Valve body

TYPE	CODE	DESCRIPTION
<b>SAE 10/2-G 3/8</b>	3CC1020C11	Aluminium body for cavity 10 valve, G 3/8 std thread
<b>SAE 12/2-G 1/2</b>	3CC1220D11	Aluminium body for cavity 12 valve, G 1/2 std thread

Note: aluminium body can stand up to 210 bar (3050 psi)  
For steel bodies or different threading see from page 215

#### 6 Accessories

TYPE	CODE	DESCRIPTION
-	4VL2407100	Handwheel
-	4COP120420	Antitampering cap

## Rating diagrams

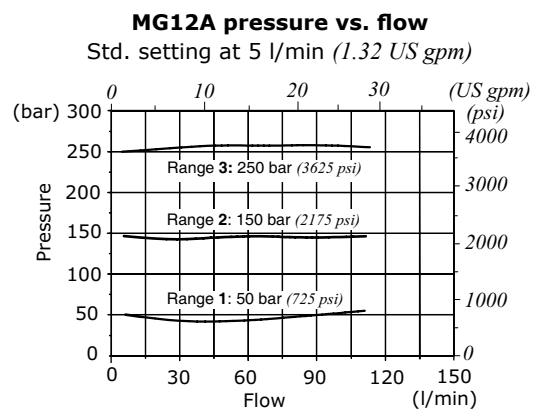
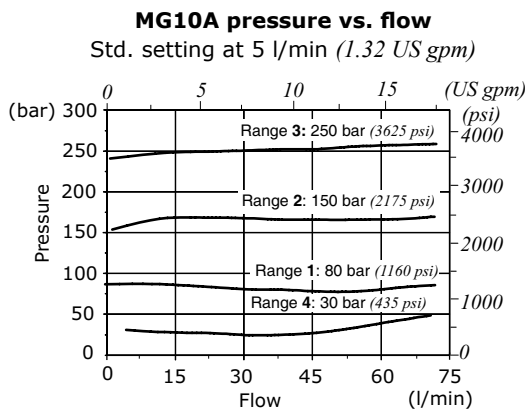



## MP..A type pressure relief valves - 2 way

- Pilot operated
- Spool type
- From SAE10 to SAE12 cavities

Technical specifications and diagrams are measured with mineral oil of 46 cSt viscosity at 40°C (104°F) temperature.

	MP10A	MP12A
Nominal flow	60 l/min (16 US gpm)	100 l/min (26.4 US gpm)
Max. pressure	350 bar (5100 psi)	
Oil leakage	80% of max. pressure setting	25 cm <sup>3</sup> /min (1.525 in <sup>3</sup> /min)
Fluid	mineral based oil	
Viscosity	10-200 cSt	
Max level of contamination	20/18/14 ISO4406	
Fluid temperature	with NBR seals with FPM seals	from -20°C (-4°F) to 80°C (176°F) from -20°C (-4°F) to 100°C (212°F)
Environmental temp. for working conditions	from -20°C (-4°F) to 50°C (122°F)	
Cavity	SAE 10/2	SAE 12/2
Weight	0.190 kg (0.42 lb)	0.300 kg (0.661 lb)

NOTE - For different conditions, please contact Walvoil Sales Dpt.

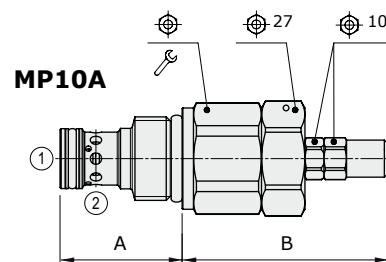
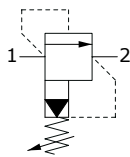

Valve type	A		B		⌀	⌘
	mm	in	mm	in		
<b>MP10A/OS</b>	32.3	1.27	54.5	2.15	27	50 37
<b>MP12A/OS</b>	46	1.81	52.5	2.07	32	80 59

For dimensions with different type of adjustment see page 212

## Ordering codes and description composition

### MP10A/0S2B

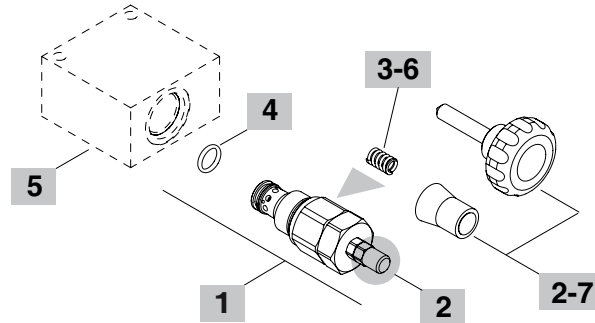
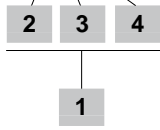

#### 1 Cartridges

TYPE	CODE	DESCRIPTION
<b>SAE cavity 10/2</b>		
MP10A/0S1B	OMP10002017	Pressure range <b>1</b>
MP10A/0S2B	OMP10002015	Pressure range <b>2</b>
MP10A/0S3B	OMP10002018	Pressure range <b>3</b>

#### SAE cavity 12/2

MP12A/0S1B	OMP12002003	Pressure range <b>1</b>
MP12A/0S2B	OMP12002000	Pressure range <b>2</b>
MP12A/0S3B	OMP12002005	Pressure range <b>3</b>

#### 2 Adjustments

TYPE	DESCRIPTION
<b>S</b>	Screw with cap
<b>V</b>	With handwheel (part code: see point <b>7</b> )
<b>X</b>	Valve set with antitampering cap (part code: see point <b>7</b> )

#### 3 Pressure range

TYPE	DESCRIPTION
<b>1</b>	Pressure range 5÷50 bar (72.5÷725 psi)
<b>2</b>	Pressure range 50÷220 bar (725÷3190 psi)
<b>3</b>	Pressure range 150÷350 bar (2175÷5100 psi)

#### 4 Seals

TYPE	DESCRIPTION
<b>B</b>	<b>NBR (Buna)</b> o-ring seals, std configuration
<b>V</b>	<b>FPM (Viton)</b> o-ring seals, contact Sales Dept.

#### 5 Valve body

TYPE	CODE	DESCRIPTION
<b>SAE 10/2-G 3/8</b>	3CC1020C11	Aluminium body for cavity 10 valve, G 3/8 std thread
<b>SAE 12/2-G 3/8</b>	3CC1220D11	Aluminium body for cavity 12 valve, G 3/8 std thread

Note: aluminium body can stand up to 210 bar (3050 psi)  
For steel bodies or different threading see from page 215

#### 6 Springs

TYPE	CODE	DESCRIPTION
<b>1</b>	3ML1081400	Pressure range <b>1</b> - white band
<b>2</b>	3ML1081401	Pressure range <b>2</b> - no band
<b>3</b>	3ML1081402	Pressure range <b>3</b> - red band

#### 7 Accessories

TYPE	CODE	DESCRIPTION
-	4VL2307007	Handwheel (for MP10A valve)
-	4VL2307001	Handwheel (for MP12A and MP16A valves)
-	4COP116420	Antitampering cap

**MP10A pressure vs. flow**

Std. setting at 5 l/min (1.32 US gpm)

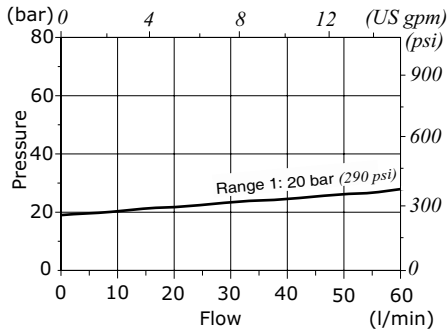

**MP10A pressure vs. flow**

Std. setting at 5 l/min (1.32 US gpm)

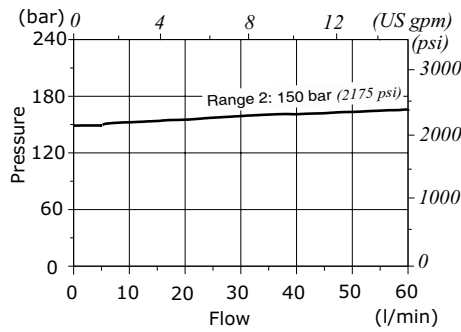

**MP10A pressure vs. flow**

Std. setting at 5 l/min (1.32 US gpm)

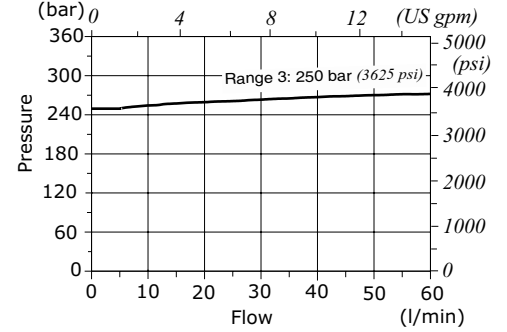

**MP12A pressure vs. flow**

Std. setting at 5 l/min (1.32 US gpm)

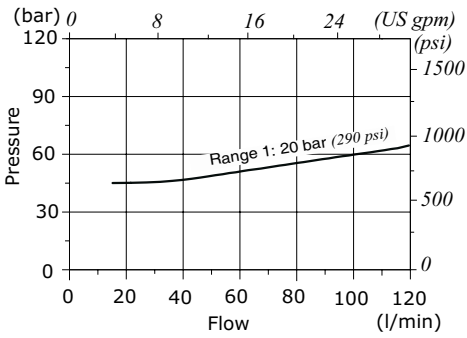

**MP12A pressure vs. flow**

Std. setting at 5 l/min (1.32 US gpm)

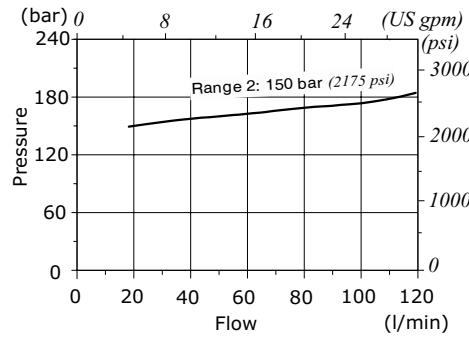

**MP12A pressure vs. flow**

Std. setting at 5 l/min (1.32 US gpm)

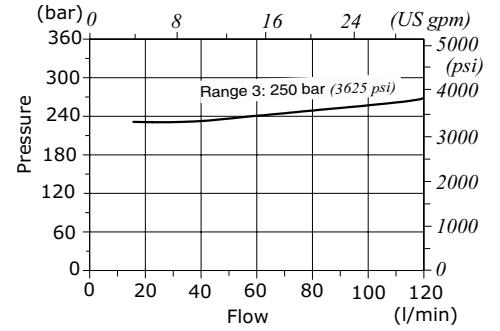





## MP16M type pressure relief valve - 2 way

- Pilot operated
- Spool type
- SAE16 cavities

Technical specifications and diagrams are measured with mineral oil of 46 cSt viscosity at 40°C (104°F) temperature.

### MP16M

Nominal flow		400 l/min (105.67 US gpm)
Max. pressure		350 bar (5100 psi)
Oil leakage	80% of max. pressure setting	100 cm <sup>3</sup> /min (6.102 in <sup>3</sup> /min)
Fluid		mineral based oil
Viscosity		12-400 cSt
Max level of contamination		20/18/14 ISO4406
Fluid temperature	with NBR seals with FPM seals	from -20°C (-4°F) to 80°C (176°F) from -20°C (-4°F) to 100°C (212°F)
Environmental temp. for working conditions		from -20°C (-4°F) to 50°C (122°F)
Cavity		SAE 16/2
Weight		0.490 kg (1.080 lb)

NOTE - For different conditions, please contact Walvoil Sales Dpt.

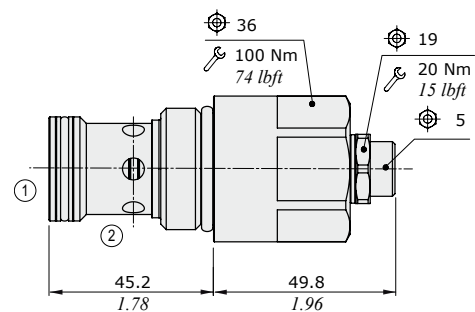
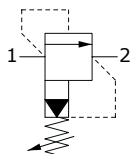

## Ordering codes and description composition

### MP16M/OY2B

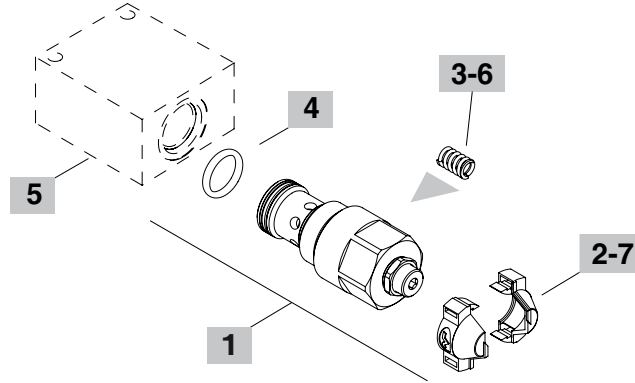
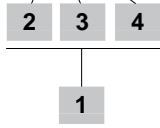

1 Cartridges			5 Valve body		
TYPE	CODE	DESCRIPTION	TYPE	CODE	DESCRIPTION
<b>SAE cavity 16/2</b>			<b>SAE 16/2-G 1</b>		
MP16M/OY1B	OMP16002017	Pressure range 1	3CC1620F210		Steel body for cavity 16 valve, G 1 std thread
MP16M/OY2B	OMP16002013	Pressure range 2	Note: aluminium body can stand up to 210 bar (3050 psi) For other bodies or different threading see from page 215		
MP16M/OY3B	OMP16002014	Pressure range 3			

2 Adjustments			6 Springs		
TYPE	DESCRIPTION		TYPE	CODE	DESCRIPTION
Y	With screw		1	3ML1081400	Pressure range 1 - white band
X	Valve set with antitampering cap (part code: see point 7)		2	3ML1081401	Pressure range 2 - no band
			3	3ML1081402	Pressure range 3 - red band

3 Pressure range			7 Accessories		
TYPE	DESCRIPTION		TYPE	CODE	DESCRIPTION
1	Pressure range 15÷50 bar (217.5÷725 psi)		-	4COP126300	Antitampering cap (x2)
2	Pressure range 50÷220 bar (725÷3190 psi)				
3	Pressure range 150÷350 bar (2175÷5100 psi)				

4 Seals		
TYPE	DESCRIPTION	
B	<b>NBR (Buna)</b> o-ring seals, std configuration	
V	<b>FPM (Viton)</b> o-ring seals, contact Sales Dept.	

## Rating diagrams

**MP16M pressure vs. flow (range 1)**  
Std. setting at 5 l/min (1.32 US gpm)

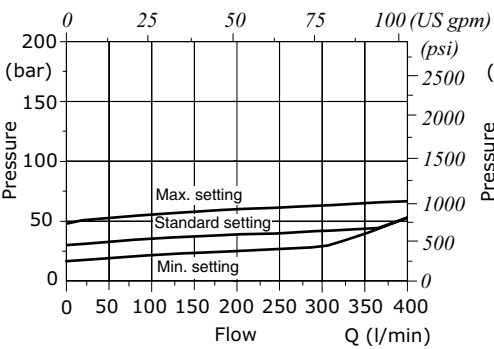

**MP16M pressure vs. flow (range 2)**  
Std. setting at 5 l/min (1.32 US gpm)

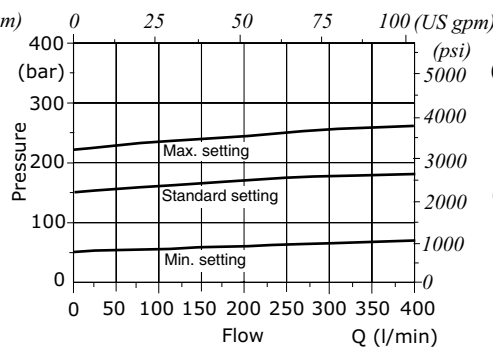

**MP16M pressure vs. flow (range 3)**  
Std. setting at 5 l/min (1.32 US gpm)

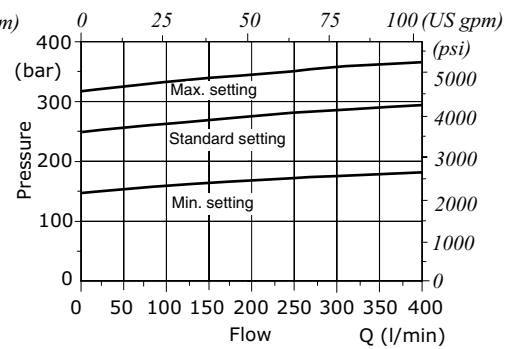





## MP..T Type pressure relief valves - 2 way

- Solenoid proportional type, pilot operated
- Decreasing pressure with increasing current (NC)
- Spool type
- From SAE10 to SAE12 cavities

Technical specifications and diagrams are measured with mineral oil of 46 cSt viscosity at 40°C (104°F) temperature.

		MP10T	MP12T
Max. flow		60 l/min (16 US gpm)	120 l/min (31.7 US gpm)
Max. pressure		350 bar (5100 psi)	
Oil leakage	at 80% of max. pressure setting	<150 cm <sup>3</sup> /min (9.15 in <sup>3</sup> /min)	<180 cm <sup>3</sup> /min (<10.1 in <sup>3</sup> /min)
Fluid		mineral based oil	
Viscosity		10-200 cSt	
Max level of contamination		18/16/13 ISO4406	
Fluid temperature	with NBR seals with FPM seals	from -20°C (-4°F) to 80°C (176°F)	from -20°C (-4°F) to 100°C (212°F)
Environmental temp. for working conditions		from -40°C (-40°F) to 100°C (212°F)	
Cavity		SAE 10/2	SAE 12/2
Coil type*		BH or BQP19	
Nominal voltages		12 VDC - 24 VDC	
Power rating		20.4 W (BH) - 15 W (BQP19)	
Max control current		12 V -> 1.70 A - 24 V -> 0.85 A (BH) 12 V -> 1.25 A - 24 V -> 0.63 A (BQP19)	
Dither frequency		200 Hz	200 Hz
Hysteresis		<5%	
Weight		0.77 kg (1.70 lb)	0.92 kg (2.03 lb)

NOTE - For different conditions, please contact Walvoil Sales Dpt. - For coils further features see from page 206.

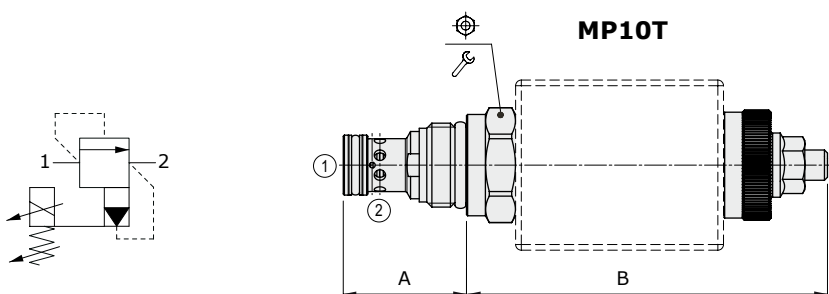

Valve type	A		B		⊕	⌘	Nm	lbft
	mm	in	mm	in				
MP10T	32.6	1.28	96.5	3.80	27	50	37	
MP12T	45	1.81	113	4.45	32	80	59	

## Ordering codes and description composition

MP10T/001B

MP10T/031B

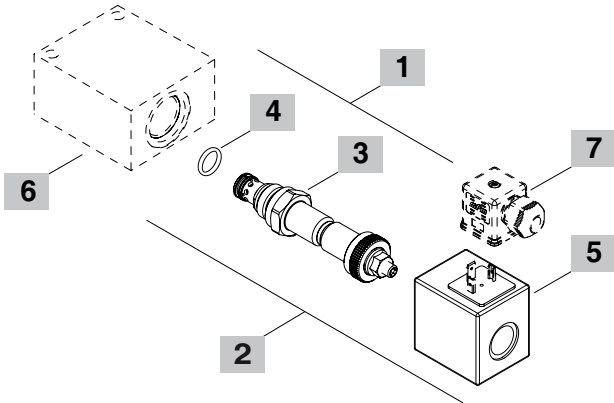

### 3 Pressure range

TYPE	DESCRIPTION
<b>1</b>	Pressure range 8÷130 bar (116÷1900 psi)
<b>2</b>	Pressure range 8÷180 bar (116÷2600 psi)
<b>3</b>	Pressure range 8÷240 bar (116÷3500 psi)
<b>4</b>	Pressure range 8÷300 bar (116÷4350 psi)

Note: for further pressure range contact Sales Dept.

### 4 Seals

TYPE	DESCRIPTION
<b>B</b>	<b>NBR (Buna)</b> o-ring seals, std configuration
<b>V</b>	<b>FPM (Viton)</b> o-ring seals, contact Sales Dept.

### 5 Coils

TYPE	CODE	DESCRIPTION
<b>2) BH 12VDC</b>	4SLD001200	12VDC-ISO4400 coil
<b>3) BQP19 12VDC</b>	4SL5000126	12VDC-ISO4400 coil
<b>4) BH 24VDC</b>	4SLD002400	24VDC-ISO4400 coil
<b>5) BQP19 24VDC</b>	4SL5000245	24VDC-ISO4400 coil

For complete coils list see from page 206

### 6 Valve body

TYPE	CODE	DESCRIPTION
<b>SAE 10/2-G 3/8</b>	3CC1020C11	Aluminium body for cavity 10 valve, G 3/8 std thread
<b>SAE 12/2-G 1/2</b>	3CC1220D11	Aluminium body for cavity 12 valve, G 1/2 std thread

Note: aluminium body can stand up to 210 bar (3050 psi)

For steel bodies or different threading see from page 215

### 7 Connector

TYPE	CODE	DESCRIPTION
<b>ISO4400</b>	4CN1009995	Connector

For complete connectors list see from page 206

### 1 Cartridges

TYPE	CODE	DESCRIPTION
<b>SAE cavity 10/2</b>		
<b>MP10T/001B</b>	OMP10002051	Pressure range <b>1</b>
<b>MP10T/002B</b>	OMP10002052	Pressure range <b>2</b>
<b>MP10T/003B</b>	OMP10002053	Pressure range <b>3</b>
<b>SAE cavity 12/2</b>		
<b>MP12T/001B</b>	OMP12002028	Pressure range <b>1</b>
<b>MP12T/002B</b>	OMP12002029	Pressure range <b>2</b>
<b>MP12T/003B</b>	OMP12002030	Pressure range <b>3</b>
<b>MP12T/004B</b>	OMP12002035	Pressure range <b>4</b>

### 2 Complete cartridges

TYPE	CODE	DESCRIPTION
<b>SAE cavity 10/2</b>		
<b>MP10T/031B</b>	OMP10002035	Pressure range <b>1</b> , 12VDC
<b>MP10T/032B</b>	OMP10002036	Pressure range <b>2</b> , 12VDC
<b>MP10T/033B</b>	OMP10002037	Pressure range <b>3</b> , 12VDC
<b>SAE cavity 12/2</b>		
<b>MP12T/031B</b>	OMP12002020	Pressure range <b>1</b> , 12VDC
<b>MP12T/032B</b>	OMP12002021	Pressure range <b>2</b> , 12VDC
<b>MP12T/033B</b>	OMP12002022	Pressure range <b>3</b> , 12VDC
<b>MP12T/034B</b>	OMP12002027	Pressure range <b>4</b> , 12VDC

## Rating diagrams

**MP10T pressure setting vs. % max. control current**  
at 5 l/min (1.32 US gpm)

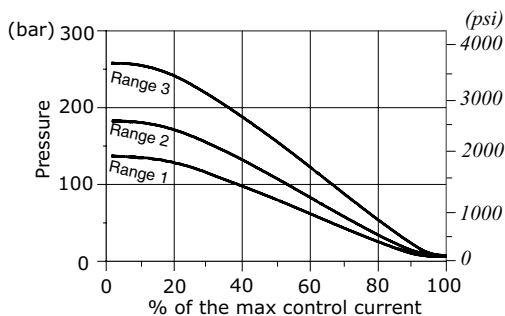

**MP10T pressure vs. flow 1->2**  
for % of control current - Pressure range **1** -

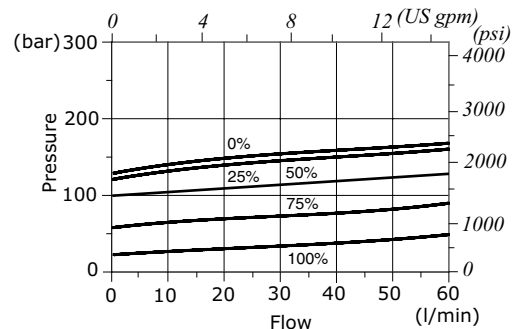

**Rating diagrams**

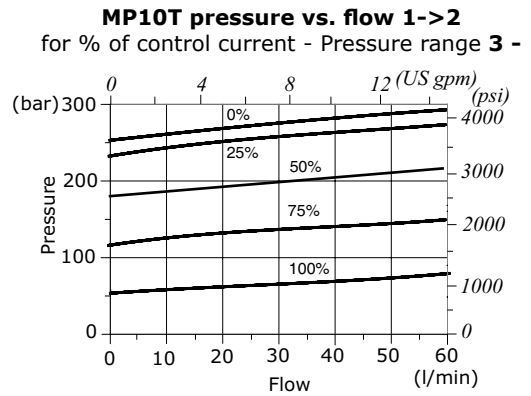
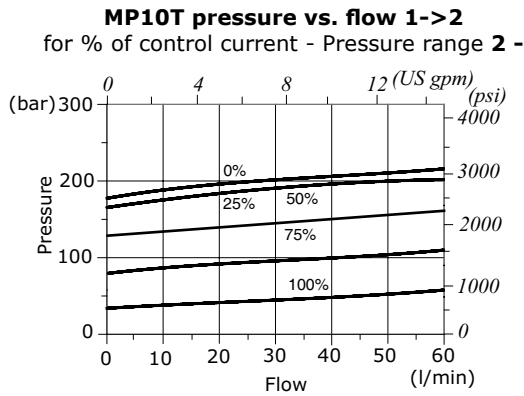

**MP12T pressure setting vs. % max. control current**  
at 10 l/min (2.6 US gpm)

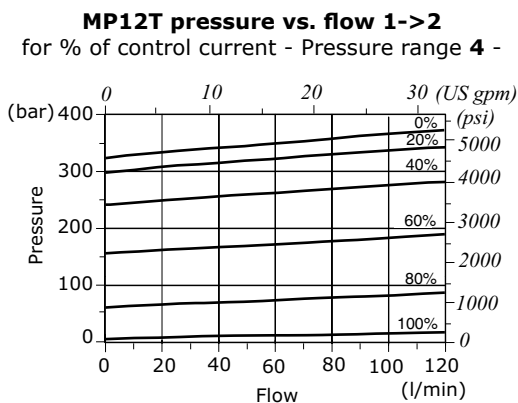
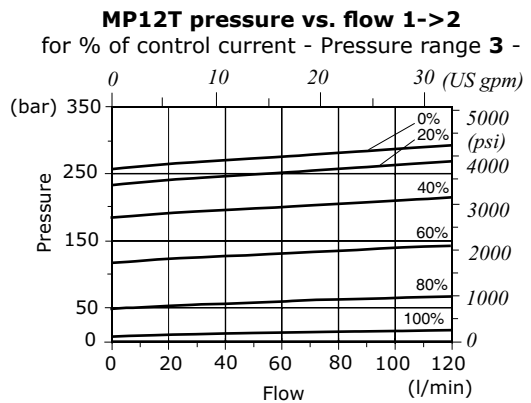
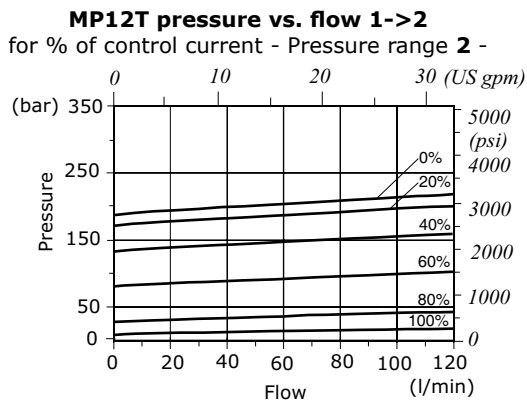
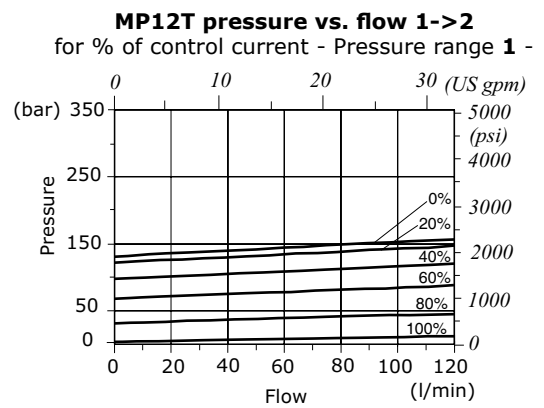
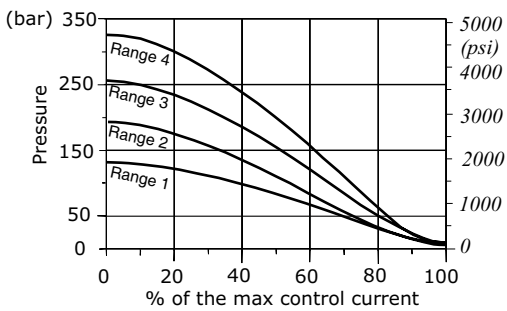





## MP..X type pressure relief valves - 2 way

- Solenoid proportional type, pilot operated
- Increasing pressure with increasing current (NO)
- Spool type
- From SAE10 to SAE12 cavities

Technical specifications and diagrams are measured with mineral oil of 46 cSt viscosity at 40°C (104°F) temperature.

		MP10X	MP12X
Max. flow		60 l/min (16 US gpm)	120 l/min (31.7 US gpm)
Max. pressure		350 bar (5100 psi)	
Oil leakage	at 80% of max. pressure setting	<150 cm <sup>3</sup> /min (9.15 in <sup>3</sup> /min)	<180 cm <sup>3</sup> /min (10.1 in <sup>3</sup> /min)
Fluid		mineral based oil	
Viscosity		10-200 cSt	
Max level of contamination		18/16/13 ISO4406	
Fluid temperature	with NBR seals with FPM seals	from -20°C (-4°F) to 80°C (176°F) from -20°C (-4°F) to 100°C (212°F)	
Environmental temp. for working conditions		from -40°C (-40°F) to 100°C (212°F)	
Cavity		SAE 10/2	SAE 12/2
Coil type*		BH or BQP19	
Nominal voltages		12 VDC - 24 VDC	
Power rating		20.4 W (BH) - 15 W (BQP19)	
Max control current		12 V -> 1.70 A - 24 V -> 0.85 A (BH) 12 V -> 1.25 A - 24 V -> 0.63 A (BQP19)	
Dither frequency		180 Hz	180 Hz
Hysteresis		<5%	
Weight		0.76 kg (1.67 lb)	0.88 kg (1.94 lb)

NOTE - For different conditions, please contact Walvoil Sales Dpt. - For coils further features see from page 206

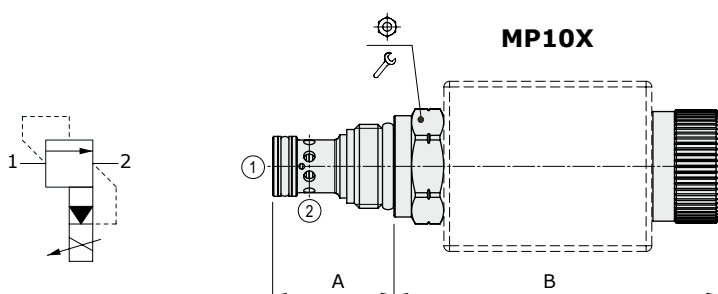

Valve type	A		B		⌀	⌘	Nm	lbft
	mm	in	mm	in				
MP10X/0	32.3	1.27	86	3.39	27	50	37	
MP12X/0	45	1.81	102	4.02	32	80	59	

For dimensions with different type of emergency see page 213

### Ordering codes and description composition

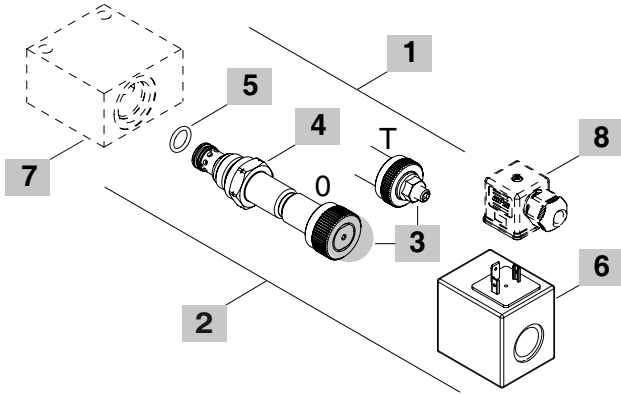
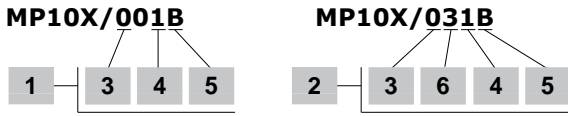

#### 1 Cartridges

TYPE	CODE	DESCRIPTION
<b>SAE cavity 10/2</b>		
MP10X/001B	OMP10002054	Pressure range 1
MP10X/002B	OMP10002055	Pressure range 2
MP10X/003B	OMP10002056	Pressure range 3
MP10X/004B	OMP10002057	Pressure range 4
<b>SAE cavity 12/2</b>		
MP12X/001B	OMP12002031	Pressure range 1
MP12X/002B	OMP12002032	Pressure range 2
MP12X/003B	OMP12002033	Pressure range 3
MP12X/004B	OMP12002034	Pressure range 4

#### 2 Complete cartridges

TYPE	CODE	DESCRIPTION
<b>SAE cavity 10/2</b>		
MP10X/031B	OMP10002044	Pressure range 1, 12VDC
MP10X/032B	OMP10002045	Pressure range 2, 12VDC
MP10X/033B	OMP10002046	Pressure range 3, 12VDC
MP10X/034B	OMP10002047	Pressure range 4, 12VDC
<b>SAE cavity 12/2</b>		
MP12X/031B	OMP12002023	Pressure range 1, 12VDC
MP12X/032B	OMP12002024	Pressure range 2, 12VDC
MP12X/033B	OMP12002025	Pressure range 3, 12VDC
MP12X/034B	OMP12002026	Pressure range 4, 12VDC

#### 3 Emergency

TYPE	DESCRIPTION
0	Without override
T	With screw

#### 4 Pressure range

TYPE	DESCRIPTION
1	Pressure range 10÷120 bar (145÷1740 psi)
2	Pressure range 10÷160 bar (145÷2320 psi)
3	Pressure range 10÷230 bar (145÷3335 psi)
4	Pressure range 10÷350 bar (145÷5100 psi)

Note: for further pressure range contact Sales Dept.

#### 5 Seals

TYPE	DESCRIPTION
B	<b>NBR (Buna)</b> o-ring seals, std configuration
V	<b>FPM (Viton)</b> o-ring seals, contact Sales Dept.

#### 6 Coils

TYPE	CODE	DESCRIPTION
2) BH 12VDC	4SLD001200	12VDC-ISO4400 coil
3) BQP19 12VDC	4SL5000126	12VDC-ISO4400 coil
4) BH 24VDC	4SLD002400	24VDC-ISO4400 coil
5) BQP19 24VDC	4SL5000245	24VDC-ISO4400 coil

For complete coils list see from page 206

#### 7 Valve body

TYPE	CODE	DESCRIPTION
<b>SAE 10/2-G 3/8</b>	3CC1020C11	Aluminium body for cavity 10 valve, G 3/8 std thread
<b>SAE 12/2-G 1/2</b>	3CC1220D11	Aluminium body for cavity 12 valve, G 1/2 std thread

Note: aluminium body can stand up to 210 bar (3050 psi)

For steel bodies or different threading see from page 215

#### 8 Connector

TYPE	CODE	DESCRIPTION
<b>ISO4400</b>	4CN1009995	Connector

For complete connectors list see from page 206

### Rating diagrams

MP10X pressure setting vs. % max. control current  
at 5 l/min (1.32 US gpm)

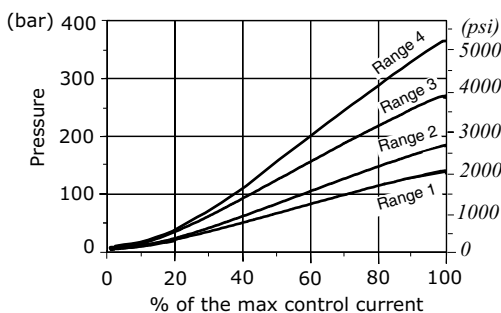

MP10X pressure vs. flow 1->2  
for % of control current - Pressure range 1 -

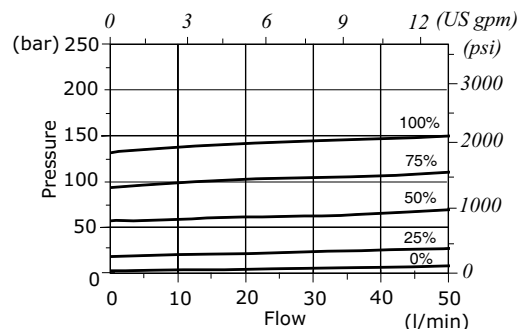

**Rating diagrams**

**MP10X pressure vs. flow 1->2**

for % of control current - Pressure range 2 -

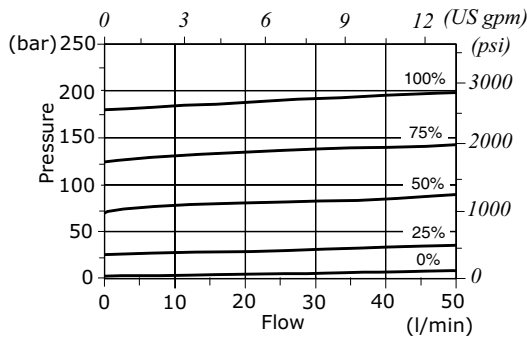

**MP10X pressure vs. flow 1->2**

for % of control current - Pressure range 3 -

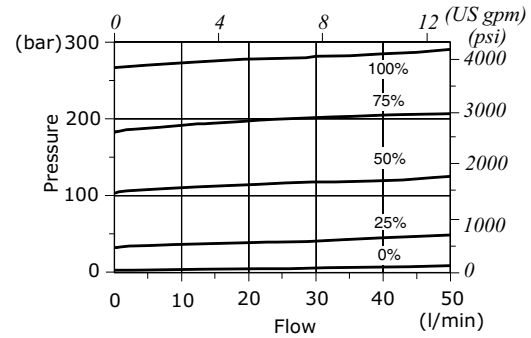

**MP10X pressure vs. flow 1->2**

for % of control current - Pressure range 4 -

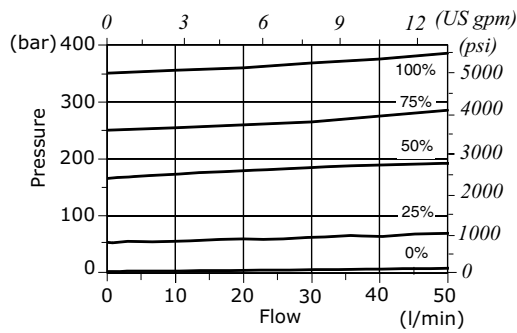

**MP12X pressure setting vs. % max. control current**

at 10 l/min (2.64 US gpm)

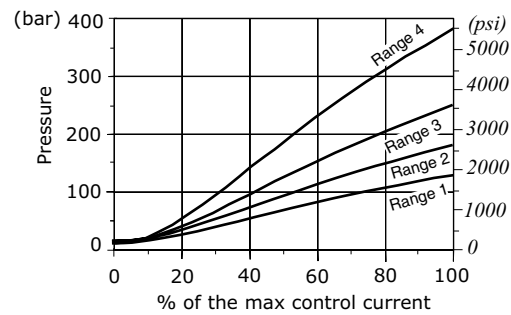

**MP12X pressure vs. flow 1->2**

for % of control current - Pressure range 1 -

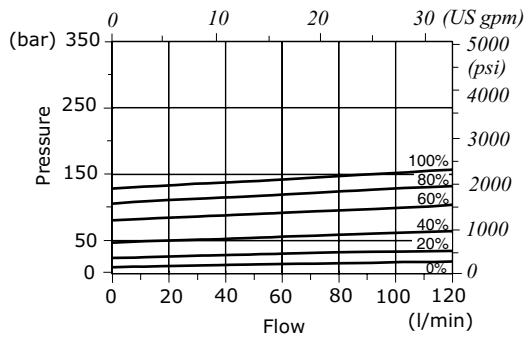

**MP12X pressure vs. flow 1->2**

for % of control current - Pressure range 2 -

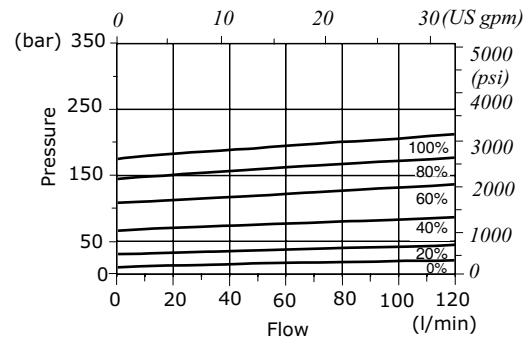

**MP12X pressure vs. flow 1->2**

for % of control current - Pressure range 3 -

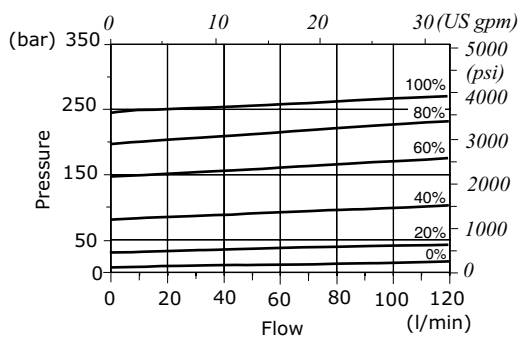

**MP12X pressure vs. flow 1->2**

for % of control current - Pressure range 4 -

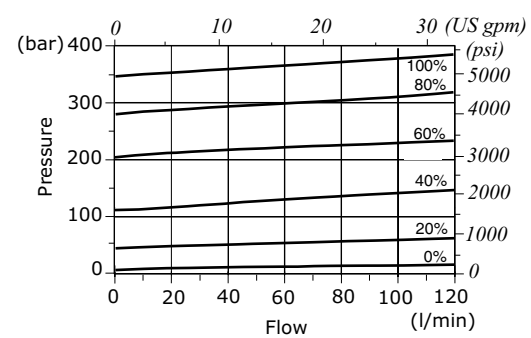







## MP16Y type pressure relief valve - 2 way

- Solenoid proportional type, pilot operated
- Increasing pressure with increasing current (NO)
- Spool type

Technical specifications and diagrams are measured with mineral oil of 46 cSt viscosity at 40°C (104°F) temperature.

MP16Y		
Nominal flow		5 l/min (1.32 US gpm)
Max. flow		150 l/min (40 US gpm)
Max. pressure		Line 1=350 bar (5100 psi); Line 2=210 bar (3045 psi)
Oil leakage	80% of max. pressure setting	200 cm <sup>3</sup> /min (12.20 in <sup>3</sup> /min)
Fluid		mineral based oil
Viscosity		10-200 cSt
Max level of contamination		18/16/13 ISO4406
Fluid temperature	with NBR seals with FPM seals	from -20°C (-4°F) to 80°C (176°F) from -20°C (-4°F) to 100°C (212°F)
Environmental temp. for working conditions		from -40°C (-40°F) to 100°C (212°F)
Cavity		SAE 16/2
Coil type*		MP35
Nominal voltages		12 VDC - 24VDC
Power rating		11.2 W (12 VDC) - 11.4 W (24 VDC)
Max control current		12 V -> 1.25 A - 24 V -> 0.68 A
Dither frequency		150 Hz
Hysteresis		≤4%
Weight		0.96 kg (2.11 lb)

NOTE - For different conditions, please contact Walvoil Sales Dpt. - For coils further features see from page 206.

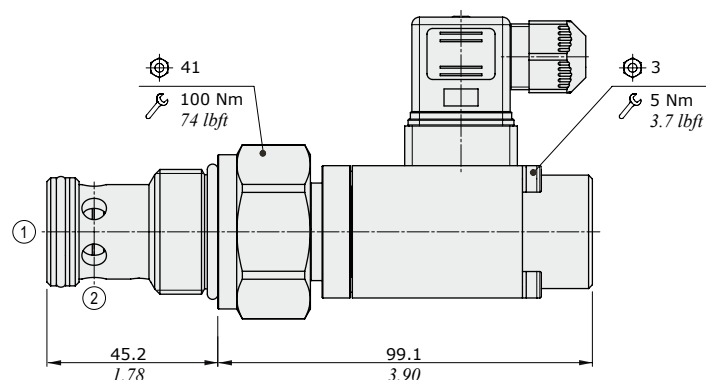
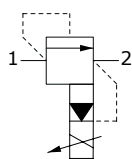

## Ordering codes and description composition

### MP16Y/021B

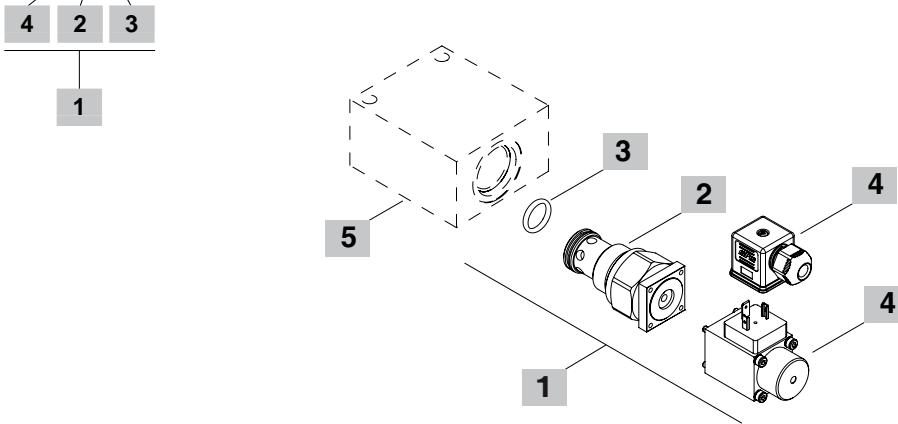

#### 1 Cartridges

TYPE	CODE	DESCRIPTION
<b>MP16Y/021B</b>	OMP16002007	Pressure range <b>1</b> , 12VDC
<b>MP16Y/022B</b>	OMP16002002	Pressure range <b>2</b> , 12VDC
<b>MP16Y/023B</b>	OMP16002009	Pressure range <b>3</b> , 12VDC
<b>MP16Y/024B</b>	OMP16002011	Pressure range <b>4</b> , 12VDC

#### 2 Pressure range

TYPE	DESCRIPTION
<b>1</b>	Pressure range 10÷100 bar (145÷1450 psi)
<b>2</b>	Pressure range 50÷200 bar (725÷2900 psi)
<b>3</b>	Pressure range 80÷350 bar (1160÷5100 psi)
<b>4</b>	Pressure range 5÷40 bar (72.5÷580 psi)

#### 3 Seals

TYPE	DESCRIPTION
<b>B</b>	<b>NBR (Buna)</b> o-ring seals, std configuration
<b>V</b>	<b>FPM (Viton)</b> o-ring seals, contact Sales Dept.

#### 4 Coils and connectors

TYPE	CODE	DESCRIPTION
<b>2) MP35 12VDC</b>	5SL4000120	12VDC-ISO4400 coil
<b>ISO4400</b>	4CN1009995	Connector
<b>4) MP35 24VDC</b>	4SL4000240	24VDC-ISO4400 coil
<b>ISO4400</b>	4CN1009995	Connector

For complete coils and connectors list see from page 206

#### 5 Valve body

TYPE	CODE	DESCRIPTION
<b>SAE 16/2-G 3/4</b>	3CC1620E11	Aluminium body for cavity 16 valve, G 3/4 std thread

Note: aluminium body can stand up to 210 bar (3050 psi)  
For steel bodies or different threading see from page 215

## Rating diagrams

Pressure setting vs.  
% max. control current  
at 5 l/min (1.32 US gpm)

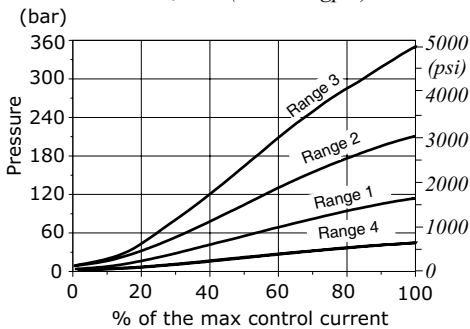

Pressure vs. flow 1->2  
with de-energized coil

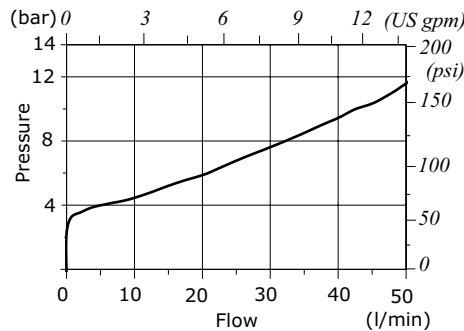

Pressure vs. flow 1->2  
for % of control current - Pressure range 2 -

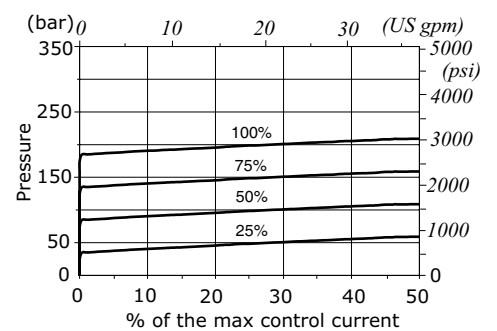



## RB..A type pressure reducing valves - 3 way

- Direct acting
- Without relieving
- Spool type
- From SAE08 to SAE10 cavities

Technical specifications and diagrams are measured with mineral oil of 46 cSt viscosity at 40°C (104°F) temperature.

		RB08A	RB10A
Nominal flow		8 l/min (0.3 US gpm)	30 l/min (7.9 US gpm)
Max. pressure			line 1=150 bar (2175 psi) line 2=350 bar (5100 psi)
Oil leakage	at 100 bar (1450 psi)	10 cm <sup>3</sup> /min (0.61 in <sup>3</sup> /min)	40 cm <sup>3</sup> /min (2.44 in <sup>3</sup> /min)
Fluid		mineral based oil	
Viscosity		10-200 cSt	
Max level of contamination		20/18/14 ISO4406	
Fluid temperature	with NBR seals with FPM seals	from -20°C (-4°F) to 80°C (176°F) from -20°C (-4°F) to 100°C (212°F)	
Environmental temp. for working conditions		from -20°C (-4°F) to 50°C (122°F)	
Cavity		SAE 08/3	SAE 10/3
Weight		0.240 kg (0.53 lb)	0.360 kg (0.79 lb)

NOTE - For different conditions, please contact Walvoil Sales Dpt.

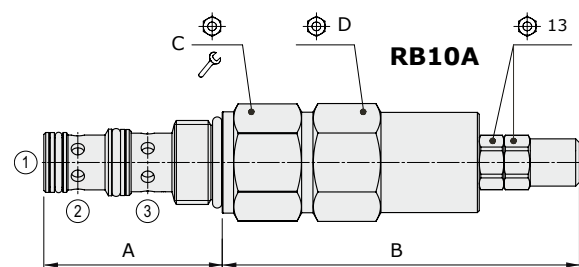
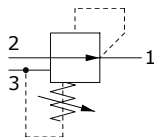

Valve type	A		B		C	D	Nm	lbft
	mm	in	mm	in				
RB08A/OS	40.8	1.60	79.5	3.13	24	24	30	22
RB10A/OS	47.2	1.86	94.5	3.72	27	27	50	37

For dimensions with different type of adjustment see page 212

### Ordering codes and description composition

#### RB08A/OS2B

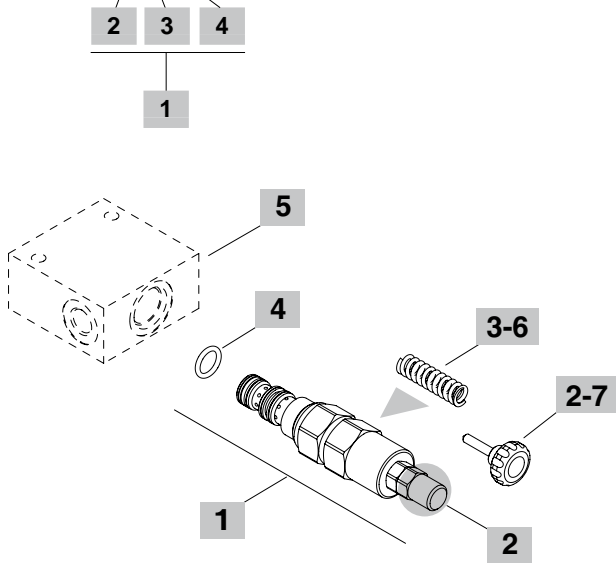

#### 1 Cartridges

TYPE	CODE	DESCRIPTION
<b>SAE cavity 08/3</b>		
RB08A/OS1B	ORB08002002	Screw adjustment, pressure range 1
RB08A/OS2B	ORB08002000	Screw adjustment, pressure range 2
<b>SAE cavity 10/3</b>		
RB10A/OS1B	ORB10002002	Screw adjustment, pressure range 1
RB10A/OS2B	ORB10002001	Screw adjustment, pressure range 2

#### 2 Adjustments

TYPE	DESCRIPTION
S	Screw
V	With handwheel see point 7

#### 3 Pressure range

Standard setting is referred to at 5 l/min (1.32 US gpm) flow

TYPE	DESCRIPTION
1	Pressure range 5÷50 bar (72.5÷725 psi); Std. setting 30 bar (435 psi)
2	Pressure range 20÷100 bar (290÷1450 psi); Std. setting 50 bar (725 psi)
3	Pressure range 50÷150 bar (725÷2175 psi); Std. setting 100 bar (1450 psi)

#### 4 Seals

TYPE	DESCRIPTION
B	<b>NBR (Buna)</b> o-ring seals, std configuration
V	<b>FPM (Viton)</b> o-ring seals, contact Sales Dept.

#### 5 Valve body

TYPE	CODE	DESCRIPTION
<b>SAE 08/3-G 1/4</b>	3CC0830B11	Aluminium body for cavity 08 valve, G 1/4 std thread
<b>SAE 10/3-G 3/8</b>	3CC1030C11	Aluminium body for cavity 10 valve, G 3/8 std thread

Note: aluminium body can stand up to 210 bar (3050 psi)  
For steel bodies or different threading see from page 217

#### 6 Springs

TYPE	CODE	DESCRIPTION
<b>SAE cavity 08/3</b>		
1	3ML1103600	Pressure range 1 - no band
2	3ML1103601	Pressure range 2 - no band
3	3ML1104000	Pressure range 3 - no band
<b>SAE cavity 10/3</b>		
1	3ML1144601	Pressure range 1 - green band
2	3ML1144602	Pressure range 2 - blue band
3	3ML1144603	Pressure range 3 - red band

#### 7 Accessories

TYPE	CODE	DESCRIPTION
-	4VL2407100	handwheel

### Rating diagrams

RB08A pressure reducing vs. flow 2->1

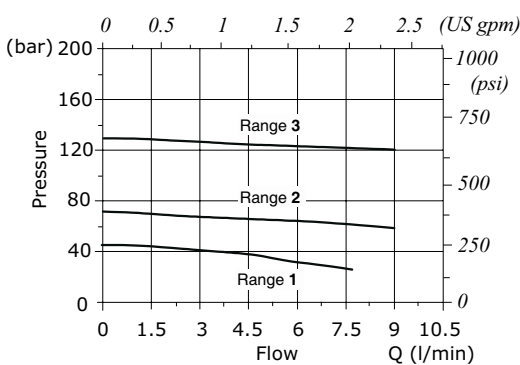

RB10A pressure reducing vs. flow 2->1

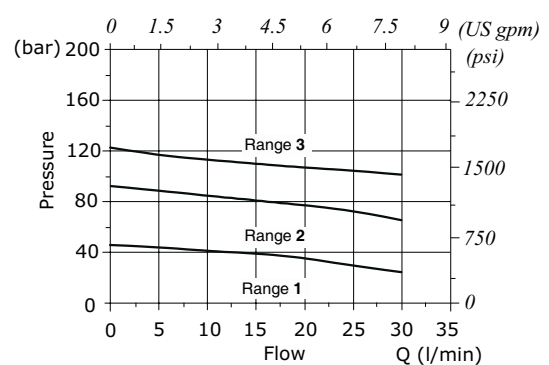



## RD..A type pressure reducing valves - 3 way

- Direct acting
- With relieving
- Spool type
- From SAE08 to SAE10 cavities

Technical specifications and diagrams are measured with mineral oil of 46 cSt viscosity at 40°C (104°F) temperature.

		RD08A	RD10A
Nominal flow		8 l/min (2.1 US gpm)	30 l/min (7.9 US gpm)
Max. pressure			line 1=150 bar (2175 psi) line 2=350 bar (5100 psi)
Oil leakage	at 100 bar (1450 psi)	10 cm <sup>3</sup> /min (0.61 in <sup>3</sup> /min)	40 cm <sup>3</sup> /min (2.44 in <sup>3</sup> /min)
Fluid		mineral based oil	
Viscosity		10-200 cSt	
Max level of contamination		20/18/14 ISO4406	
Fluid temperature	with NBR seals with FPM seals	from -20°C (-4°F) to 80°C (176°F) from -20°C (-4°F) to 100°C (212°F)	
Environmental temp. for working conditions		from -20°C (-4°F) to 50°C (122°F)	
Cavity		SAE 08/3	SAE 10/3
Weight		0.240 kg (0.53 lb)	0.360 kg (0.79 lb)

NOTE - For different conditions, please contact Walvoil Sales Dpt.

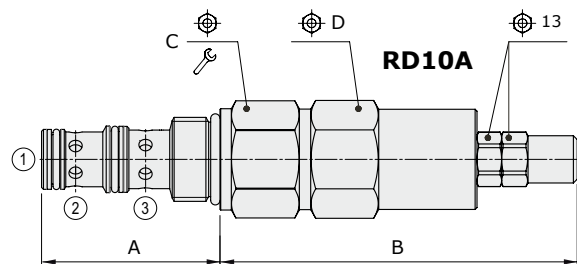
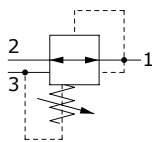

Valve type	A		B		C	D	Nm	lbft
	mm	in	mm	in				
RD08A/OS	40.8	1.60	79.5	3.13	24	24	30	22
RD10A/OS	47.2	1.86	94.5	3.72	27	27	50	37

For dimensions with different type of adjustment see page 212

### Ordering codes and description composition

#### RD08A/OS2B

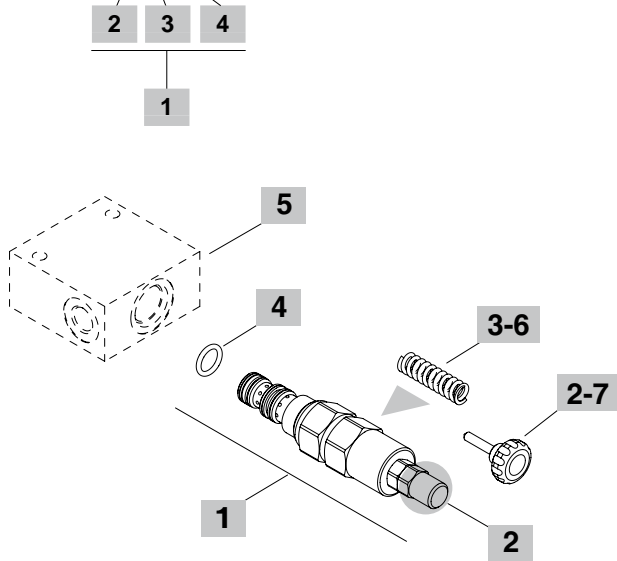

#### 1 Cartridges

TYPE	CODE	DESCRIPTION
<b>SAE cavity 08/3</b>		
RD08A/OS1B	ORD08002003	Screw adjustment, pressure range 1
RD08A/OS2B	ORD08002005	Screw adjustment, pressure range 2
RD08A/OS3B	ORD08002000	Screw adjustment, pressure range 3
<b>SAE cavity 10/3</b>		
RD10A/OS1B	ORD10002003	Screw adjustment, pressure range 1
RD10A/OS2B	ORD10002001	Screw adjustment, pressure range 2
RD10A/OS3B	ORD10002000	Screw adjustment, pressure range 3

#### 2 Adjustments

TYPE	DESCRIPTION
S	Screw
V	With handwheel see point 7

#### 3 Pressure range

Standard setting is referred to at 5 l/min (1.32 US gpm) flow

TYPE	DESCRIPTION
1	Pressure range 5÷50 bar (72.5÷725 psi); Std. setting 30 bar (435 psi)
2	Pressure range 20÷100 bar (290÷1450 psi); Std. setting 50 bar (725 psi)
3	Pressure range 50÷150 bar (725÷2175 psi); Std. setting 100 bar (1450 psi)

#### 4 Seals

TYPE	DESCRIPTION
B	<b>NBR (Buna)</b> o-ring seals, std configuration
V	<b>FPM (Viton)</b> o-ring seals, contact Sales Dept.

#### 5 Valve body

TYPE	CODE	DESCRIPTION
<b>SAE 08/3-G 1/4</b>	3CC0830B11	Aluminium body for cavity 08 valve, G 1/4 std thread
<b>SAE 10/3-G 3/8</b>	3CC1030C11	Aluminium body for cavity 10 valve, G 3/8 std thread

Note: aluminium body can stand up to 210 bar (3050 psi)  
For steel bodies or different threading see page 217

#### 6 Springs

TYPE	CODE	DESCRIPTION
<b>SAE cavity 08/3</b>		
1	3ML1103600	Pressure range 1 - no band
2	3ML1103601	Pressure range 2 - no band
3	3ML1104000	Pressure range 3 - no band
<b>SAE cavity 10/3</b>		
1	3ML1144601	Pressure range 1 - green band
2	3ML1144602	Pressure range 2 - blue band
3	3ML1144603	Pressure range 3 - red band

#### 7 Accessories

TYPE	CODE	DESCRIPTION
-	4VL2407100	handwheel

### Rating diagrams

RD08A reducing/relieving pressure vs. flow

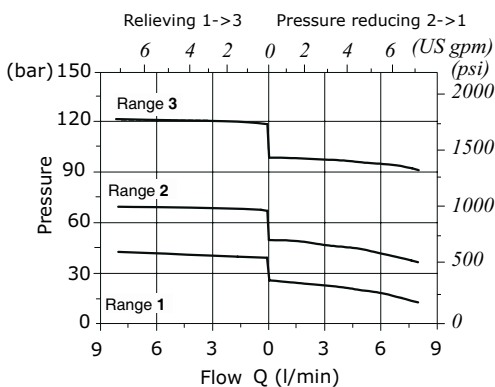

RD10A reducing/relieving pressure vs. flow

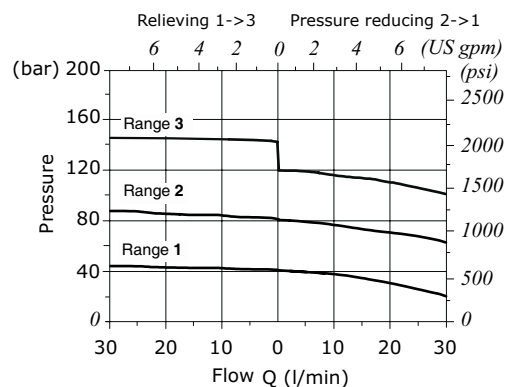



## RD08W type pressure reducing valve - 3 way

- Solenoid proportional type, direct acting
- With relieving (NO)
- Spool type

Technical specifications and diagrams are measured with mineral oil of 46 cSt viscosity at 40°C (104°F) temperature.

RD08W		
Nominal flow		4 l/min (1.05 US gpm)
Max. pressure		350 bar (5100 psi)
Oil leakage		-
Fluid		mineral based oil
Viscosity		10-200 cSt
Max level of contamination		18/16/13 ISO4406
Fluid temperature	with NBR seals with FPM seals	from -20°C (-4°F) to 80°C (176°F) from -20°C (-4°F) to 100°C (212°F)
Environmental temp. for working conditions		from -40°C (-40°F) to 100°C (212°F)
Cavity		SAE 08/3
Coil type*		MP35
Nominal voltages		12 VDC - 24 VDC
Power rating		11.2 W (12 VDC) - 11.4 W (24 VDC)
Max control current		12 V -> 1.25 A - 24 V -> 0.68 A
Dither frequency		150 Hz
Hysteresis		≤4%
Weight		0.680 kg (1.50 lb)

NOTE - For different conditions, please contact Walvoil Sales Dpt. - For coils further features see from page 206.

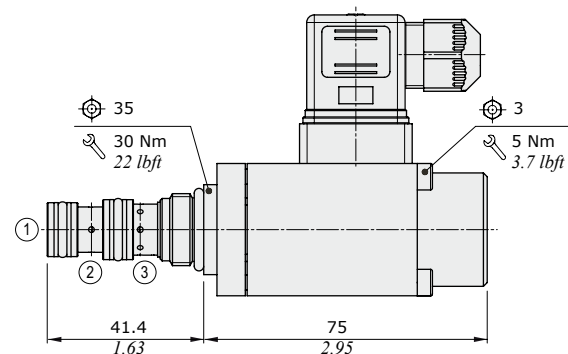
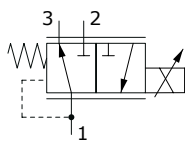

### Ordering codes and description composition

#### RD08W/021B

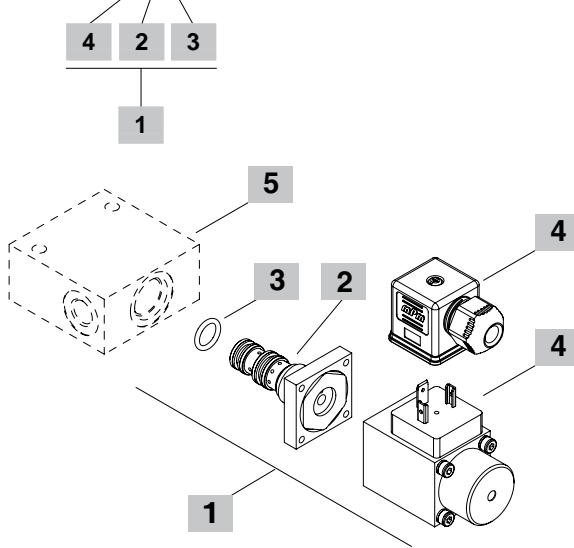

#### 1 Cartridges

TYPE	CODE	DESCRIPTION
RD08W/021B	ORD08002001	Pressure range 1, 12VDC

#### 2 Pressure range

TYPE	DESCRIPTION
1	Pressure range 5÷25 bar (72.5÷363 psi)
2	Pressure range 0÷12 bar (0÷174 psi)

#### 3 Seals

TYPE	DESCRIPTION
B	NBR (Buna) o-ring seals, std configuration
V	FPM (Viton) o-ring seals, contact Sales Dept.

#### 4 Coils and connectors

TYPE	CODE	DESCRIPTION
2) MP35 12VDC	5SL4000120	12VDC-ISO4400 coil
ISO4400	4CN1009995	Connector
4) MP35 24VDC	4SL4000240	24VDC-ISO4400 coil
ISO4400	4CN1009995	Connector

For complete coils and connectors list see from page 206

#### 5 Valve body

TYPE	CODE	DESCRIPTION
SAE 08/3-G 1/4	3CC0830B11	Aluminium body for cavity 08 valve, G 1/4 std thread

Note: aluminium body can stand up to 210 bar (3050 psi)  
For steel bodies or different threading see from page 217

### Rating diagrams

Pressure drop vs. flow 2->1  
Pressure range 1

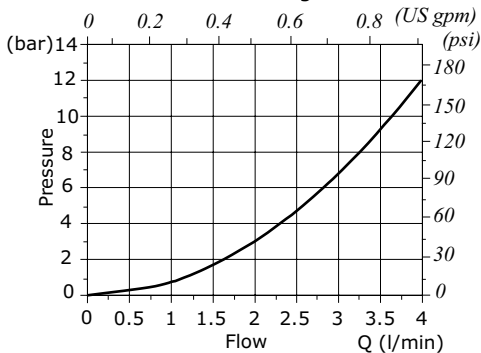

Pressure drop vs. flow 1->2  
Pressure range 1

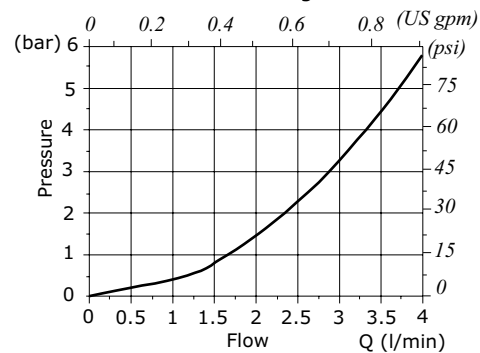

Pressure reducing vs. control current

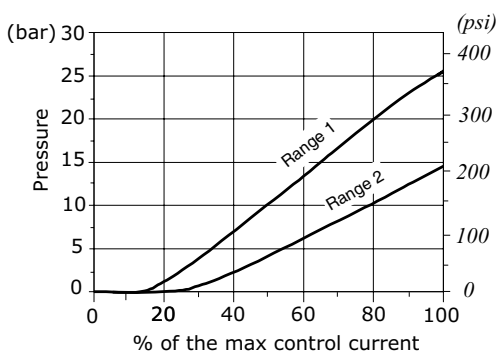

Reducing/relieving pressure vs. flow  
for % of control current - Pressure range 1

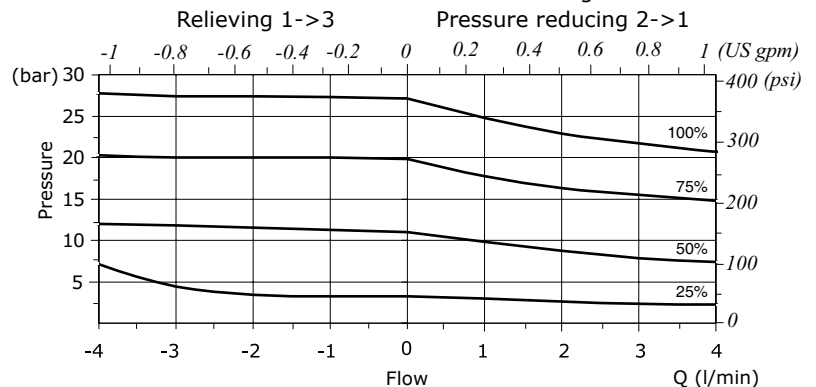





### RD08S-RD08T type pressure reducing valves - 3 way

- Solenoid proportional type, direct acting
- With relieving (NO)
- Spool type

Technical specifications and diagrams are measured with mineral oil of 46 cSt viscosity at 40°C (104°F) temperature.

	RD08S	RD08T
Nominal flow	4 l/min (1.05 US gpm)	12 l/min (3.17 US gpm)
Max. pressure	210 bar (3050 psi)	
Oil leakage	-	
Fluid	mineral based oil	
Viscosity	10-200 cSt	
Max level of contamination	18/16/13 ISO4406	
Fluid temperature	with NBR seals with FPM seals	from -20°C (-4°F) to 80°C (176°F) from -20°C (-4°F) to 100°C (212°F)
Environmental temp. for working conditions	from -40°C (-40°F) to 100°C (212°F)	
Cavity	SAE 08/3	SAE 8/3
Coil type*	MSM 19	
Nominal voltages	12 VDC - 24 VDC	
Power rating	21.6 W (12 VDC) - 22.5 W (24 VDC)	
Max control current	12 V -> 1.25 A - 24 V -> 0.68A	
Dither frequency	150 Hz	
Hysteresis	≤4%	
Weight	0.492 kg (1.08 lb)	1.140 kg (0.79 lb)

NOTE - For different conditions, please contact Walvoil Sales Dpt. - For coils further features see from page 206.

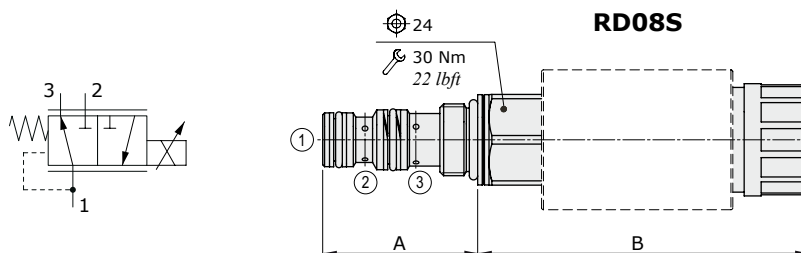

Valve type	A		B	
	mm	in	mm	in
RD08S	41	1.61	87.5	1.27
RD08T	41	1.61	97	1.81

## Ordering codes and description composition

### RD08S/003B



### RD08S/023B

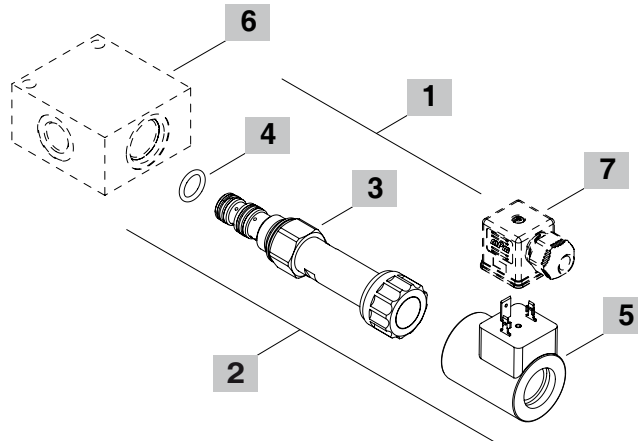

### 1 Cartridges

TYPE	CODE	DESCRIPTION
<b>RD08S/003B</b>	ORD08002025	Pressure range <b>3</b>
<b>RD08T/001B</b>	ORD08002016	Pressure range <b>1</b>

### 2 Complete cartridges

TYPE	CODE	DESCRIPTION
<b>RD08S/023B</b>	ORD08002023	Pressure range <b>3</b> , 12VDC
<b>RD08T/021B</b>	ORD08002024	Pressure range <b>1</b> , 12VDC

### 3 Pressure range

TYPE	DESCRIPTION
<b>1</b>	Pressure range 5÷45 bar (72.5÷652.5 psi) for cartridge RD08T type
<b>3</b>	Pressure range 5÷35 bar (72.5÷507.5 psi) for cartridge RD08S type

### 4 Seals

TYPE	DESCRIPTION
<b>B</b>	<b>NBR (Buna)</b> o-ring seals, std configuration
<b>V</b>	<b>FPM (Viton)</b> o-ring seals, contact Sales Dept.

### 5 Coils

TYPE	CODE	DESCRIPTION
<b>2) MSM 19 12VDC</b>	4SL5000128	12VDC-ISO4400 coil
<b>4) MSM 19 24VDC</b>	4SL5000247	24VDC-ISO4400 coil

For complete coils list see page 206

### 6 Valve body

TYPE	CODE	DESCRIPTION
<b>SAE 08/3-G 3/8</b>	3CC0830C11	Aluminium body for cavity 8 valve, G 3/8 std thread

Note: aluminium body can stand up to 210 bar (3050 psi)  
For steel bodies or different threading see from page 217

### 7 Connector

TYPE	CODE	DESCRIPTION
<b>ISO4400</b>	4CN1009995	Connector

For complete connectors list see from page 206

**RD08S pressure reducing vs. control current**  
12 VDC power supply

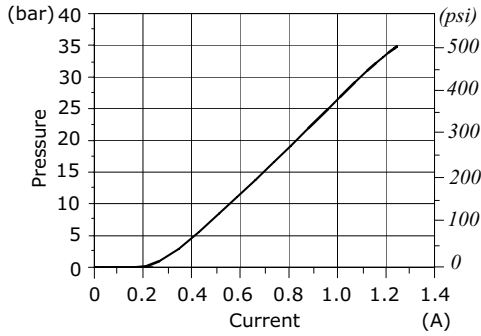

**RD08S pressure drop vs. flow 2->1**

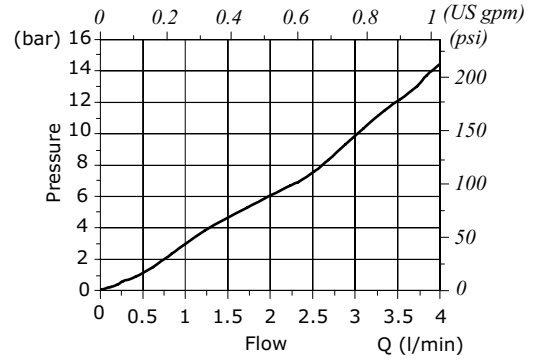

**RD08S reducing/relieving pressure vs. flow**  
for % of control current

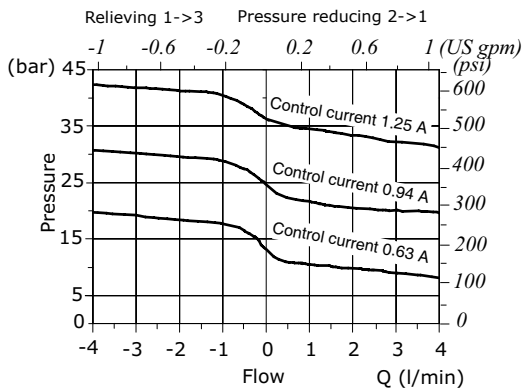

**RD08T pressure reducing vs. control current**  
12 VDC power supply

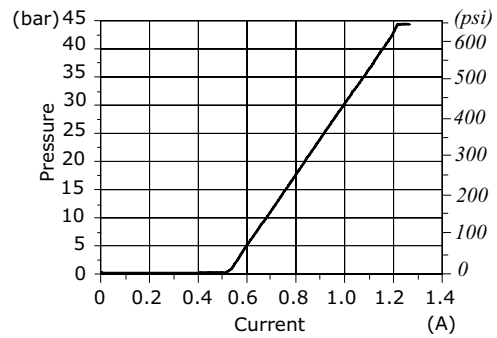

**RD08T pressure drop vs. flow 2->1**

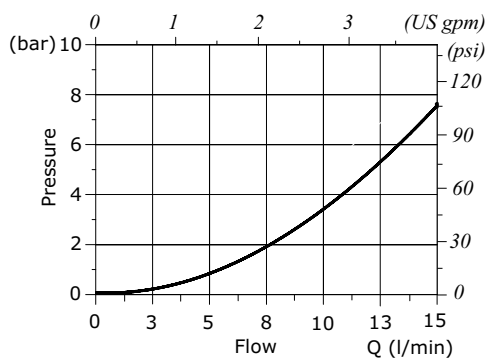

**RD08T reducing/relieving pressure vs. flow**  
for % of control current

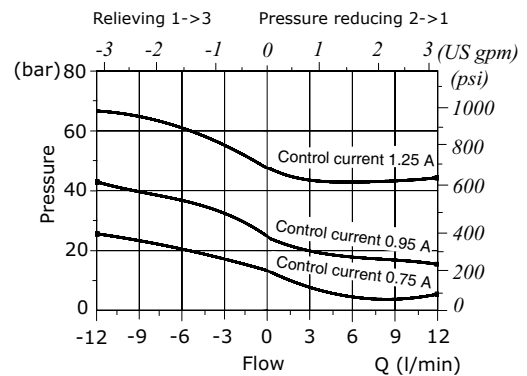





## RM..A type pressure reducing valves - 3 way

- Pilot operated
- Without relieving
- Spool type
- From SAE10 to SAE16 cavities

Technical specifications and diagrams are measured with mineral oil of 46 cSt viscosity at 40°C (104°F) temperature.

	RM10A	RM12A	RM16A
Nominal flow	50 l/min (13 US gpm)	100 l/min (26 US gpm)	150 l/min (40 US gpm)
Max. pressure		350 bar (5100 psi)	
Oil leakage		-	
Fluid		mineral based oil	
Viscosity		10-200 cSt	
Max level of contamination		20/18/14 ISO4406	
Fluid temperature	with NBR seals with FPM seals	from -20°C (-4°F) to 80°C (176°F) from -20°C (-4°F) to 100°C (212°F)	
Environmental temp. for working conditions		from -20°C (-4°F) to 50°C (122°F)	
Cavity	SAE 10/3	SAE 12/3	SAE 16/3
Weight	0.210 kg (0.46 lb)	0.340 kg (0.75 lb)	0.470 kg (1.04 lb)

NOTE - For different conditions, please contact Walvoil Sales Dpt.

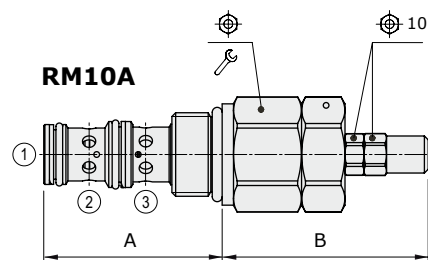
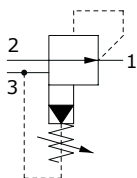

Valve type	A		B		⌀	Wrench icon
	mm	in	mm	in		
<b>RM10A/1S</b>	47.2	1.86	54.5	2.15	27	50 37
<b>RM12A/0S</b>	73.5	2.89	51.5	2.03	32	70 52
<b>RM16A/0S</b>	75	2.95	50.5	1.99	41	100 74

For dimensions with different type of adjustment see page 212

### Ordering codes and description composition

#### RM10A/1S1B

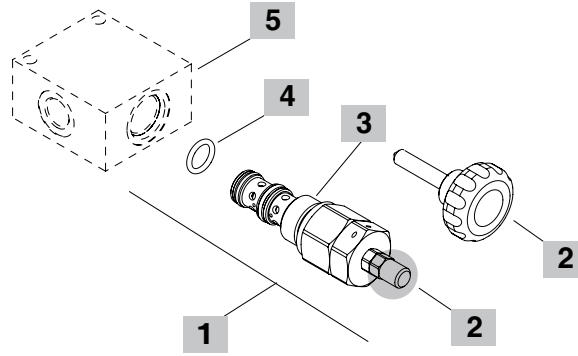
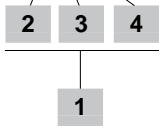

#### 1 Cartridges

TYPE	CODE	DESCRIPTION
<b>SAE cavity 10/3</b>		
RM10A/1S1B	ORM10002012	Pressure range 1
RM10A/1S2B	ORM10002013	Pressure range 2
RM10A/1S3B	ORM10002014	Pressure range 3
<b>SAE cavity 12/3</b>		
RM12A/0S1B	ORM12002008	Pressure range 1
RM12A/0S2B	ORM12002000	Pressure range 2
RM12A/0S3B	ORM12002016	Pressure range 3
<b>SAE cavity 16/3</b>		
RM16A/0S1B	ORM16002008	Pressure range 1
RM16A/0S2B	ORM16002000	Pressure range 2
RM16A/0S3B	ORM16002009	Pressure range 3

#### 3 Adjustments

TYPE	DESCRIPTION
S	Screw with cap
V	With handwheel

#### 3 Pressure range

Standard setting is referred to at 5 l/min (1.32 US gpm) flow

TYPE	DESCRIPTION
1	Pressure range 5÷80 bar (72.5÷1160 psi); Std. setting 50 bar (725 psi)
2	Pressure range 50÷220 bar (725÷3190 psi); Std. setting 150 bar (2175 psi)
3	<b>For SAE cavity 10/3:</b> pressure range 100÷350 bar (1450÷5075 psi); Std. setting 250 bar (3625 psi) <b>For SAE cavity 12/3 and 16/3:</b> pressure range 180÷350 bar (2610÷5075 psi); Std. setting 250 bar (3625 psi)

#### 4 Seals

TYPE	DESCRIPTION
B	<b>NBR (Buna)</b> o-ring seals, std configuration
V	<b>FPM (Viton)</b> o-ring seals, contact Sales Dept.

#### 5 Valve body

TYPE	CODE	DESCRIPTION
<b>SAE 10/3-G 3/8</b>	3CC1030C11	Aluminium body for cavity 10 valve, G 3/8 std thread
<b>SAE 12/3-G 1/2</b>	3CC1230D11	Aluminium body for cavity 12 valve, G 1/2 std thread
<b>SAE 16/3-G 3/4</b>	3CC1630E11	Aluminium body for cavity 16 valve, G 3/4 std thread

Note: aluminium body can stand up to 210 bar (3050 psi)  
For steel bodies or different threading see from page 217

**Rating diagrams**

**RM10A pressure drop vs. flow 2->1**

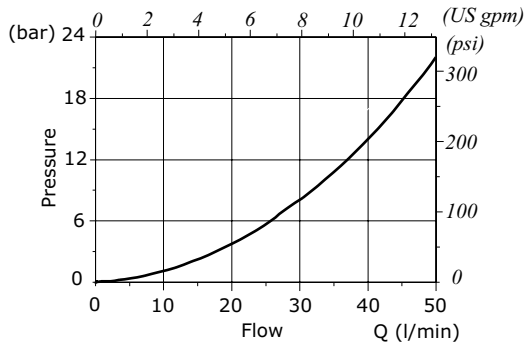

**RM10A pressure reducing vs. flow 2->1**

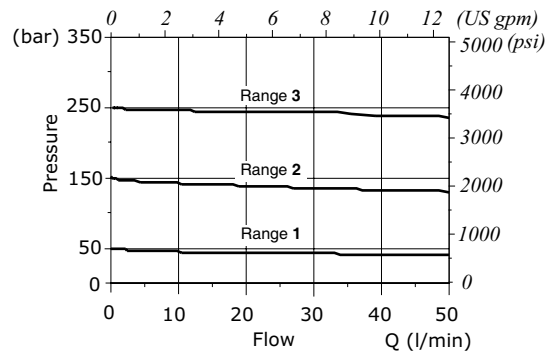

**RM12A pressure reducing vs. flow 2->1**

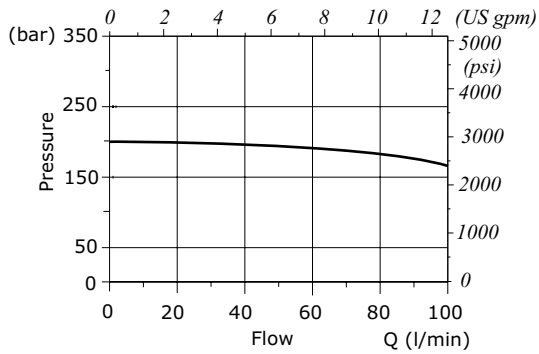

**RM16A pressure drop vs. flow 2->1**

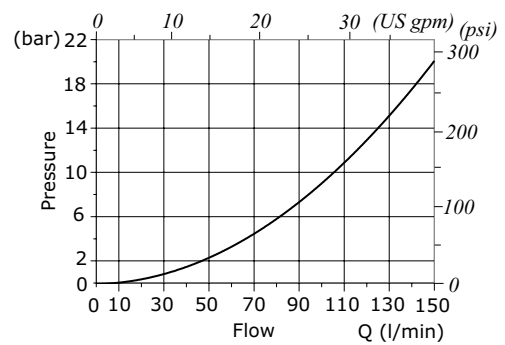

**RM16A pressure reducing vs. flow 2->1**

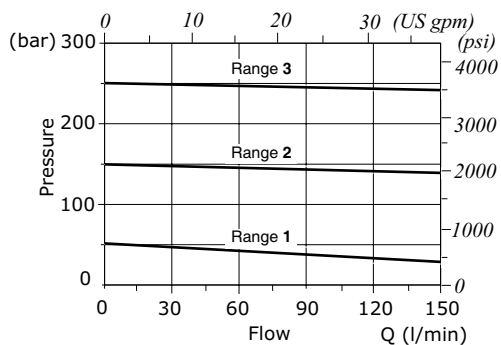







## RM..W type pressure reducing valves - 3 way

- Solenoid proportional type, pilot operated
- Without relieving
- Spool type
- From SAE10 to SAE16 cavities

Technical specifications and diagrams are measured with mineral oil of 46 cSt viscosity at 40°C (104°F) temperature.

	RM10W	RM12W	RM16W
Nominal flow	50 l/min (13 US gpm)	100 l/min (26 US gpm)	150 l/min (40 US gpm)
Max. pressure	350 bar (5100 psi)		
Oil leakage	-		
Fluid	mineral based oil		
Viscosity	10-200 cSt		
Max level of contamination	18/16/13 ISO4406		
Fluid temperature	with NBR seals with FPM seals	from -20°C (-4°F) to 80°C (176°F) from -20°C (-4°F) to 100°C (212°F)	
Environmental temp. for working conditions	from -20°C (-4°F) to 50°C (122°F)		
Cavity	SAE 10/3	SAE 12/3	SAE 16/3
Coil type*	MP35		
Nominal voltages	12 VDC - 24 VDC		
Power rating	11.2 W (12 VDC) - 11.4 W (24 VDC)		
Max control current	12 V -> 1.25 A - 24 V -> 0.68 A		
Dither frequency	150 Hz		
Hysteresis	≤4%		
Weight	0.680 kg (1.50 lb)	0.820 kg (1.81 lb)	0.930 kg (2.05 lb)

NOTE - For different conditions, please contact Walvoil Sales Dpt. - For coils further features see from page 206

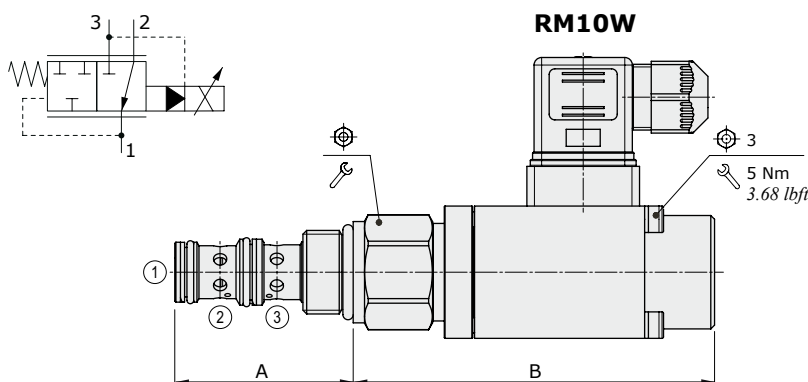

Valve type	A		B		⊕	⌘	Nm	lbft
	mm	in	mm	in				
RM10W	47.2	1.86	95.6	3.76	27	50	37	
RM12W	73.5	2.89	93.5	3.68	32	70	52	
RM16W	75	2.95	92	3.62	41	100	74	

### Ordering codes and description composition

#### RM10W/121B

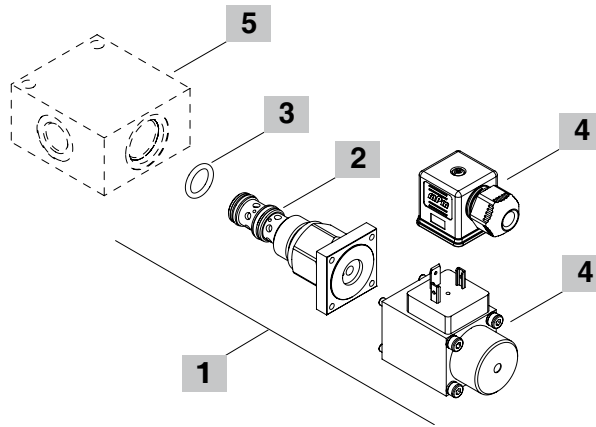
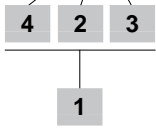

#### 1 Cartridges

TYPE	CODE	DESCRIPTION
<b>SAE cavity 10/3</b>		
RM10W/121B	ORM10002015	Pressure range <b>1</b> , 12VDC
RM10W/122B	ORM10002016	Pressure range <b>2</b> , 12VDC
RM10W/123B	ORM10002017	Pressure range <b>3</b> , 12VDC
RM10W/124B	ORM10002018	Pressure range <b>4</b> , 12VDC
<b>SAE cavity 12/3</b>		
RM12W/021B	ORM12002003	Pressure range <b>1</b> , 12VDC
RM12W/022B	ORM12002005	Pressure range <b>2</b> , 12VDC
RM12W/024B	ORM12002001	Pressure range <b>4</b> , 12VDC
<b>SAE cavity 16/3</b>		
RM16W/021B	ORM16002004	Pressure range <b>1</b> , 12VDC
RM16W/022B	ORM16002005	Pressure range <b>2</b> , 12VDC
RM16W/023B	ORM16002006	Pressure range <b>3</b> , 12VDC
RM16W/024B	ORM16002001	Pressure range <b>4</b> , 12VDC

#### 2 Pressure range

TYPE	DESCRIPTION
<b>1</b>	Pressure range 5÷50 bar (72.5÷725 psi)
<b>2</b>	Pressure range 50÷200 bar (725÷2900 psi)
<b>3</b>	Pressure range 80÷350 bar (1160÷5100 psi)
<b>4</b>	Pressure range 20÷100 bar (290÷1450 psi) Pressure range 10÷80 bar (145÷1160 psi) only for RM12W/024B

#### 3 Seals

TYPE	DESCRIPTION
<b>B</b>	<b>NBR (Buna)</b> o-ring seals, std configuration
<b>V</b>	<b>FPM (Viton)</b> o-ring seals, contact Sales Dept.

#### 4 Coils and connectors

TYPE	CODE	DESCRIPTION
<b>2) MP35 12VDC</b>	5SL4000120	12VDC-ISO4400 coil
<b>ISO4400</b>	4CN1009995	Connector
<b>4) MP35 24VDC</b>	4SL4000240	24VDC-ISO4400 coil
<b>ISO4400</b>	4CN1009995	Connector

For complete coils and connectors list see from page 206

#### 5 Valve body

TYPE	CODE	DESCRIPTION
<b>SAE 10/3-G 3/8</b>	3CC1030C11	Aluminium body for cavity 10 valve, G 3/8 std thread
<b>SAE 12/3-G 1/2</b>	3CC1230D11	Aluminium body for cavity 12 valve, G 1/2 std thread
<b>SAE 16/3-G 3/4</b>	3CC1630E11	Aluminium body for cavity 16 valve, G 3/4 std thread

Note: aluminium body can stand up to 210 bar (3050 psi)  
For steel bodies or different threading see from page 217

**RM10W pressure drop vs. flow 2->1**

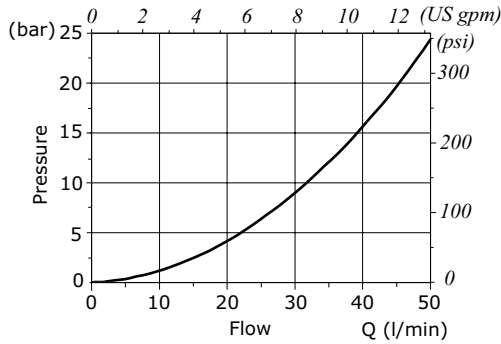

**RM10W pressure reducing vs. control current**

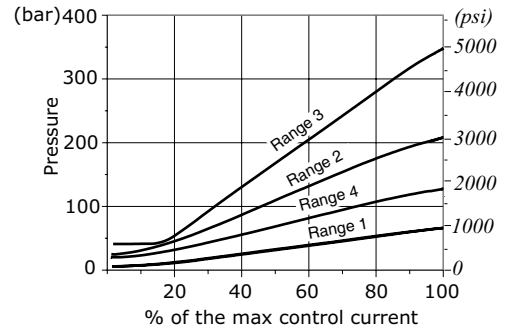

**RM10W pressure reducing vs. flow for % of control current - Pressure range 2 -**

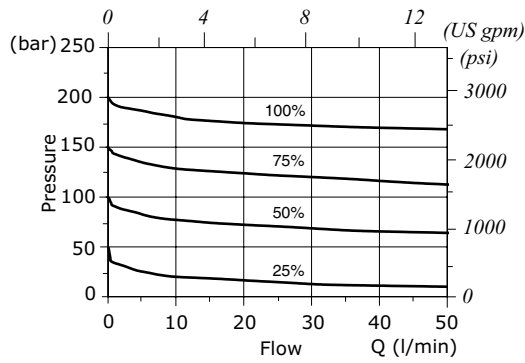

**RM12W pressure drop vs. flow 2->1**

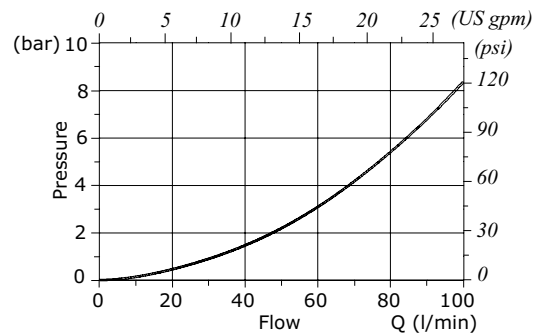

**RM12W pressure reducing vs. control current**

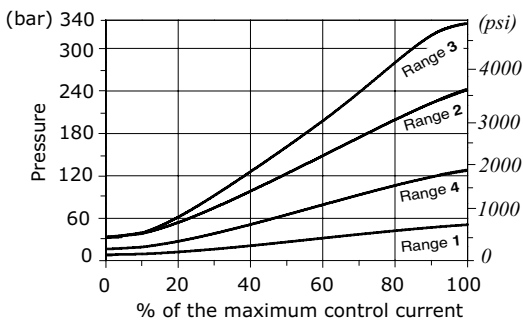

**RM12W pressure reducing vs. flow for % of control current - Pressure range 2 -**

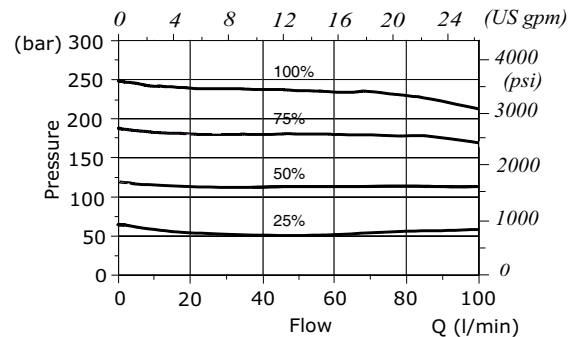

Rating diagrams

RM16W pressure vs. flow 2->1

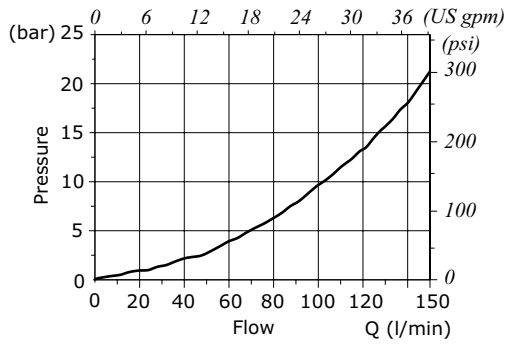

RM16W pressure setting vs. % max. control current

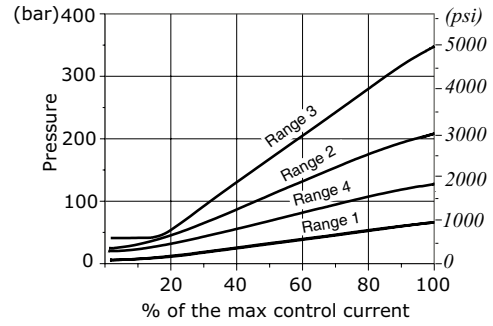

RM16W pressure reducing vs. flow  
for % of control current - Pressure range 2 -

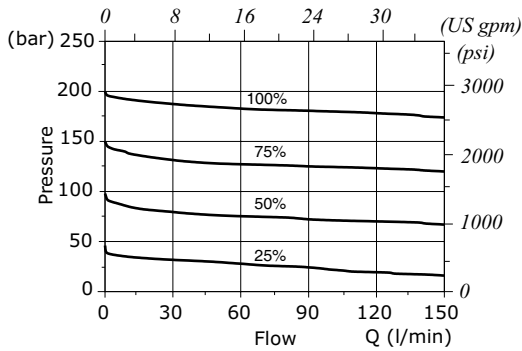



## RP..A type pressure reducing valves - 3 way

- Pilot operated
- With relieving
- Spool type
- From SAE10 to SAE16 cavities

Technical specifications and diagrams are measured with mineral oil of 46 cSt viscosity at 40°C (104°F) temperature.

	RP10A	RP12A	RP16A
Nominal flow	50 l/min (7.9 US gpm)	100 l/min (26 US gpm)	150 l/min (40 US gpm)
Max. pressure	350 bar (5100 psi)		
Oil leakage	-		
Fluid	mineral based oil		
Viscosity	10-200 cSt		
Max level of contamination	20/18/14 ISO4406		
Fluid temperature	with NBR seals with FPM seals	from -20°C (-4°F) to 80°C (176°F) from -20°C (-4°F) to 100°C (212°F)	
Environmental temp. for working conditions	from -20°C (-4°F) to 50°C (122°F)		
Cavity	SAE 10/3	SAE 12/3	SAE 16/3
Weight	0.210 kg (0.46 lb)	0.330 kg (0.72 lb)	0.420 kg (0.92 lb)

NOTE - For different conditions, please contact Walvoil Sales Dpt.

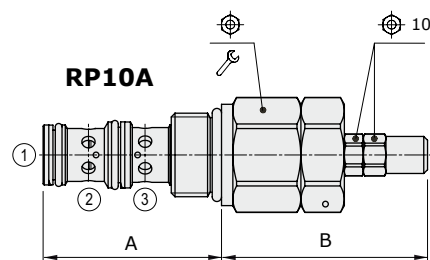
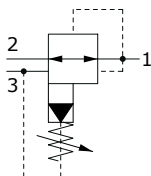

Valve type	A		B		⌀	Key	Nm	lbft
	mm	in	mm	in				
RP10A/1S	47.2	1.86	54.5	2.15	27	50	37	
RP12A/0S	73.5	2.89	51.5	2.03	32	80	59	
RP16A/0S	75	2.95	50.5	1.99	41	100	74	

For dimensions with different type of adjustment see page 212

### Ordering codes and description composition

#### RP10A/1S1B

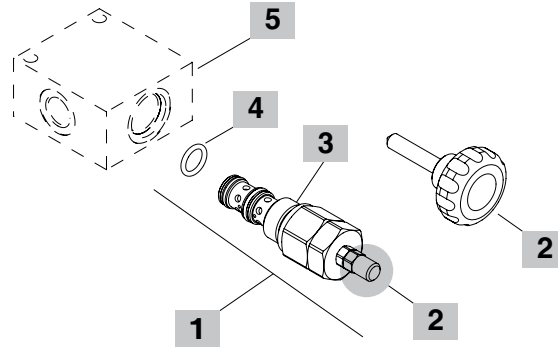
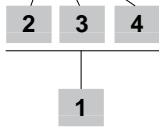

#### 1 Cartridges

TYPE	CODE	DESCRIPTION
<b>SAE cavity 10/3</b>		
RP10A/1S1B	ORP10002016	Pressure range <b>1</b>
RP10A/1S2B	ORP10002017	Pressure range <b>2</b>
RP10A/1S3B	ORP10002018	Pressure range <b>3</b>
<b>SAE cavity 12/3</b>		
RP12A/0S1B	ORP12002002	Pressure range <b>1</b>
RP12A/0S2B	ORP12002003	Pressure range <b>2</b>
RP12A/0S3B	ORP12002000	Pressure range <b>3</b>
<b>SAE cavity 16/3</b>		
RP16A/0S1B	ORP16002006	Pressure range <b>1</b>
RP16A/0S2B	ORP16002000	Pressure range <b>2</b>
RP16A/0S3B	ORP16002011	Pressure range <b>3</b>

#### 2 Adjustments

TYPE	DESCRIPTION
<b>S</b>	Screw with cap
<b>V</b>	With handwheel

#### 3 Pressure range

Standard setting is referred to at 5 l/min (1.32 US gpm) flow

TYPE	DESCRIPTION
<b>1</b>	Pressure range 5÷80 bar (72.5÷1160 psi); Std. setting 50 bar (725 psi) at 5 l/min (1.32 US gpm)
<b>2</b>	Pressure range 50÷220 bar (725÷3190 psi); Std. setting 150 bar (2175 psi) at 5 l/min (1.32 US gpm)
<b>3</b>	<b>For SAE cavity 10/3:</b> pressure range 100÷350 bar (1450÷5075 psi); Std. setting 250 bar (3625 psi) <b>For SAE cavity 12/3 and 16/3:</b> pressure range 180÷350 bar (2610÷5075 psi); Std. setting 250 bar (3625 psi)

#### 4 Seals

TYPE	DESCRIPTION
<b>B</b>	<b>NBR (Buna)</b> o-ring seals, std configuration
<b>V</b>	<b>FPM (Viton)</b> o-ring seals, contact Sales Dept.

#### 5 Valve body

TYPE	CODE	DESCRIPTION
<b>SAE 10/3-G 3/8</b>	3CC1030C11	Aluminium body for cavity 10 valve, G 3/8 std thread
<b>SAE 12/3-G 1/2</b>	3CC1230D11	Aluminium body for cavity 12 valve, G 1/2 std thread
<b>SAE 16/3-G 3/4</b>	3CC1630E11	Aluminium body for cavity 16 valve, G 3/4 std thread

Note: aluminium body can stand up to 210 bar (3050 psi)

For steel bodies or different threading see from page 217

**RP10A pressure drop vs. flow**

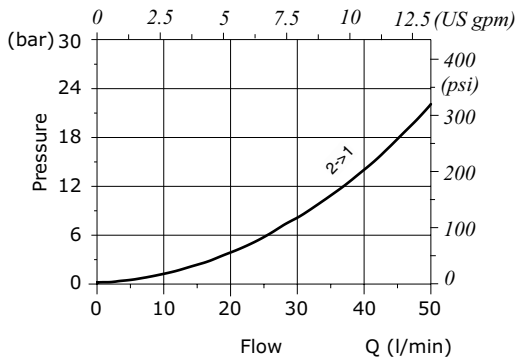

**RP10A reducing/relieving pressure vs. flow**

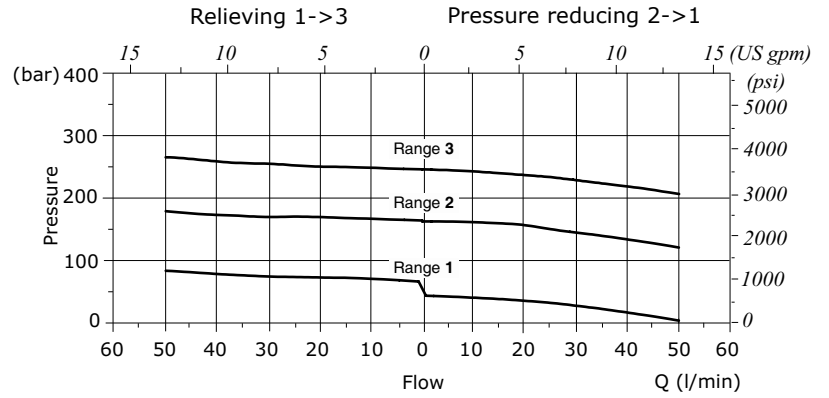

**RP12A pressure drop vs. flow**

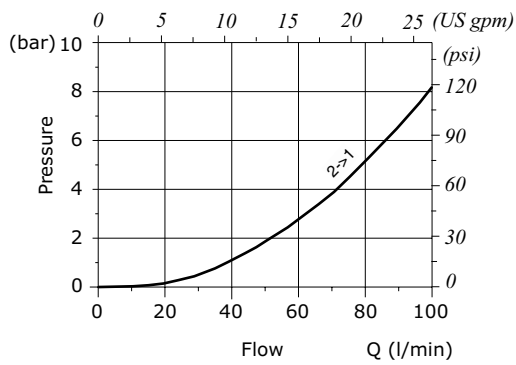

**RP12A reducing/relieving pressure vs. flow**

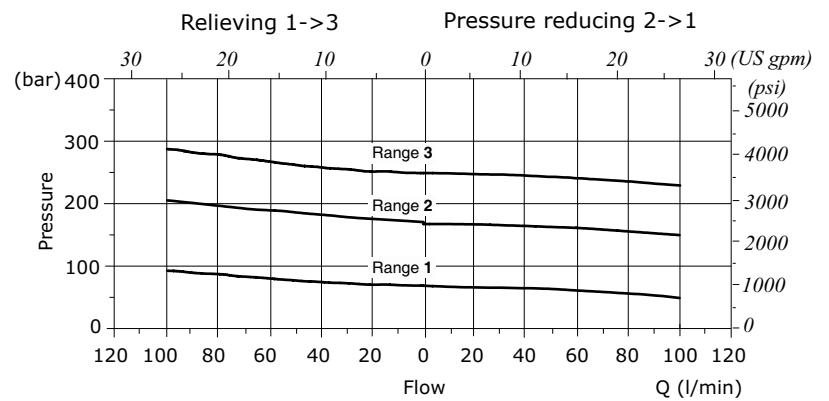

**RP16A pressure drop vs. flow**

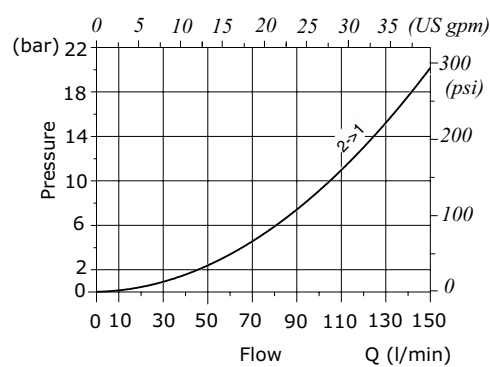

**RP16A reducing/relieving pressure vs. flow**

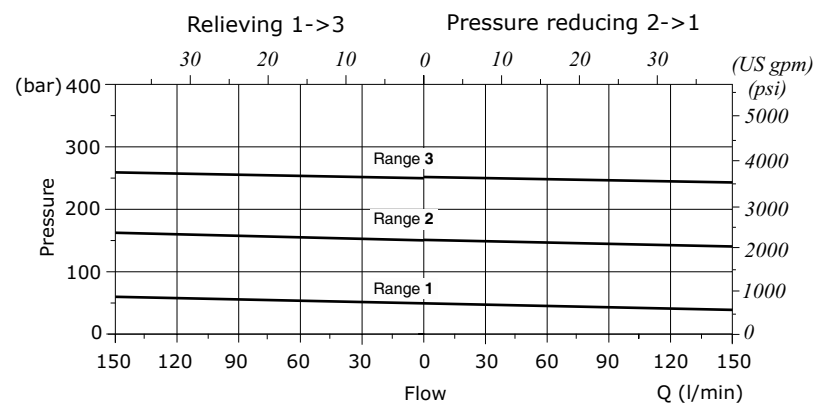







## RP..W type pressure reducing valves - 3 way

- Solenoid proportional type, pilot operated
- With relieving
- Spool type
- From SAE10 to SAE16 cavities

Technical specifications and diagrams are measured with mineral oil of 46 cSt viscosity at 40°C (104°F) temperature.

	RP10W	RP12W	RP16W
Nominal flow	50 l/min (13 US gpm)	100 l/min (26 US gpm)	150 l/min (40 US gpm)
Max. pressure	350 bar (5100 psi) - in 3=210 bar (3045 psi)		
Oil leakage	-		
Fluid	mineral based oil		
Viscosity	10-200 cSt		
Max level of contamination	18/16/13 ISO4406		
Fluid temperature	with NBR seals with FPM seals	from -20°C (-4°F) to 80°C (176°F) from -20°C (-4°F) to 100°C (212°F)	
Environmental temp. for working conditions	from -20°C (-4°F) to 50°C (122°F)		
Cavity	SAE 10/3	SAE 12/3	SAE 16/3
Coil type*	MP35		
Nominal voltages	12 VDC - 24 VDC		
Power rating	11.2 W (12 VDC) - 11.4 W (24 VDC)		
Max control current	12 V -> 1.25 A - 24 V -> 0.68 A		
Dither frequency	150 Hz		
Hysteresis	≤4%		
Weight	0.680 kg (1.50 lb)	0.820 kg (1.81 lb)	0.930 kg (2.05 lb)

NOTE - For different conditions, please contact Walvoil Sales Dpt. - For coils further features see from page 206.

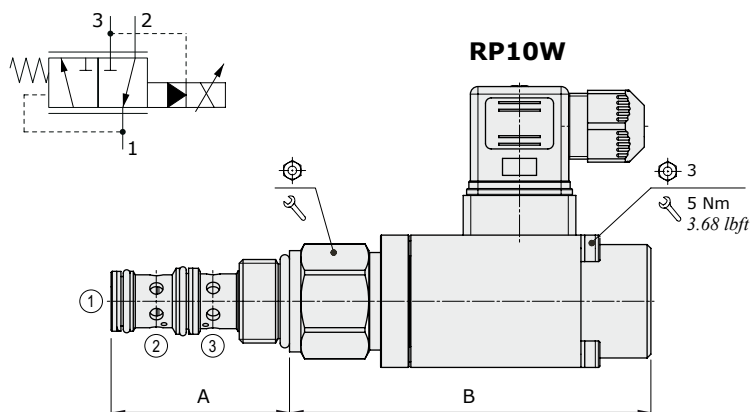

Valve type	A		B		⌀	Torque	Torque
	mm	in	mm	in			
RP10W	47.2	1.86	95.6	3.76	27	50	37
RP12W	73.5	2.89	93.5	3.68	32	70	52
RP16W	75	2.95	92	3.62	41	100	74

### Ordering codes and description composition

#### RP10W/121B

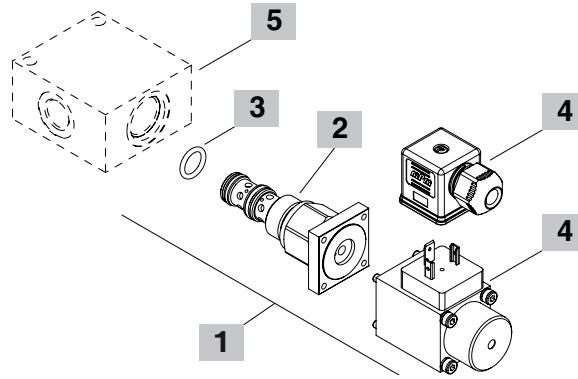
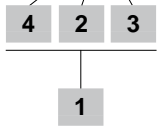

#### 1 Cartridges

TYPE	CODE	DESCRIPTION
<b>SAE cavity 10/3</b>		
RP10W/121B	ORP10002020	Pressure range <b>1</b> , 12VDC
RP10W/122B	ORP10002021	Pressure range <b>2</b> , 12VDC
RP10W/123B	ORP10002022	Pressure range <b>3</b> , 12VDC
RP10W/124B	ORP10002023	Pressure range <b>4</b> , 12VDC
<b>SAE cavity 12/3</b>		
RP12W/021B	ORP12002007	Pressure range <b>1</b> , 12VDC
RP12W/022B	ORP12002009	Pressure range <b>2</b> , 12VDC
RP12W/024B	ORP12002005	Pressure range <b>3</b> , 12VDC
<b>SAE cavity 16/3</b>		
RP16W/021B	ORP16002004	Pressure range <b>1</b> , 12VDC
RP16W/022B	ORP16002008	Pressure range <b>2</b> , 12VDC
RP16W/023B	ORP16002009	Pressure range <b>3</b> , 12VDC
RP16W/024B	ORP16002001	Pressure range <b>4</b> , 12VDC

#### 2 Pressure range

TYPE	DESCRIPTION
<b>1</b>	Pressure range 5÷50 bar (72.5÷725 psi)
<b>2</b>	Pressure range 50÷200 bar (725÷2900 psi)
<b>3</b>	Pressure range 80÷350 bar (1160÷5075 psi)
<b>4</b>	Pressure range 20÷100 bar (290÷1450 psi) Pressure range 10÷80 bar (145÷1160 psi) only for RP12W/024B

#### 3 Seals

TYPE	DESCRIPTION
<b>B</b>	<b>NBR (Buna)</b> o-ring seals, std configuration
<b>V</b>	<b>FPM (Viton)</b> o-ring seals, contact Sales Dept.

#### 4 Coils and connectors

TYPE	CODE	DESCRIPTION
<b>2) MP35 12VDC</b>	5SL4000120	12VDC-ISO4400 coil
<b>ISO4400</b>	4CN1009995	Connector
<b>4) MP35 24VDC</b>	4SL4000240	24VDC-ISO4400 coil
<b>ISO4400</b>	4CN1009995	Connector

For complete coils and connectors list see from page 206

#### 5 Valve body

TYPE	CODE	DESCRIPTION
<b>SAE 10/3-G 3/8</b>	3CC1030C11	Aluminium body for cavity 10 valve, G 3/8 std thread
<b>SAE 12/3-G 1/2</b>	3CC1230D11	Aluminium body for cavity 12 valve, G 1/2 std thread
<b>SAE 16/3-G 3/4</b>	3CC1630E11	Aluminium body for cavity 16 valve, G 3/4 std thread

Note: aluminium body can stand up to 210 bar (3050 psi)  
For steel bodies or different threading see from page 217

**RP10W pressure drop vs. flow 2->1**

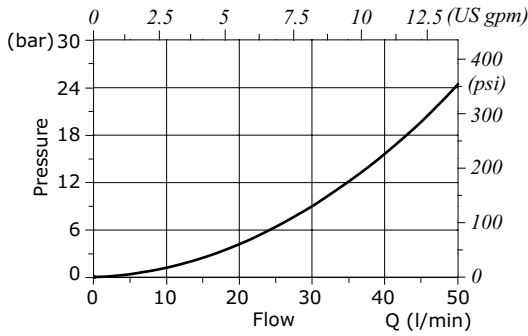

**RP10W pressure drop vs. flow 1->3 with de-energized coil**

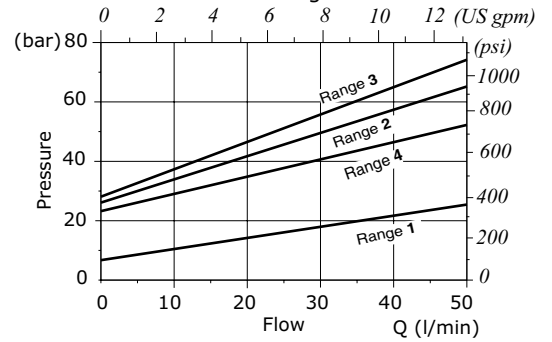

**RP10W reducing/relieving pressure vs. flow for % of control current - Pressure range 2**

**RP10W pressure reducing vs. control current**

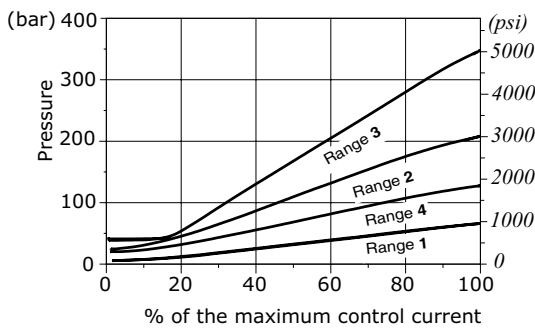

**Relieving 1->3 Pressure reducing 2->1**

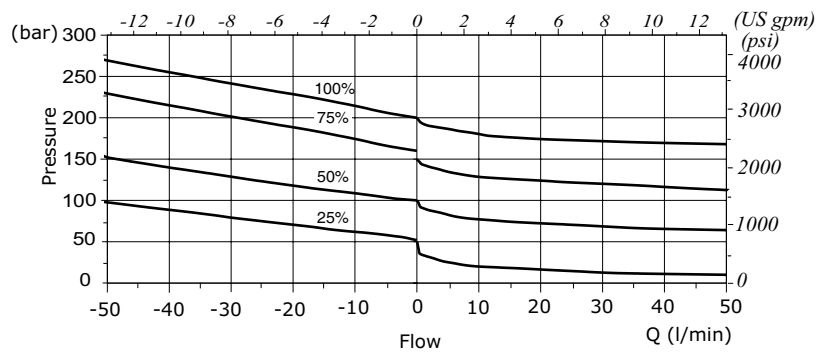

**RP12W pressure drop vs. flow 2->1**

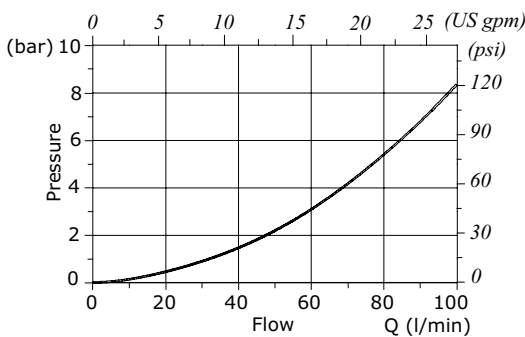

**RP12W pressure drop vs. flow 1->3 with de-energized coil**

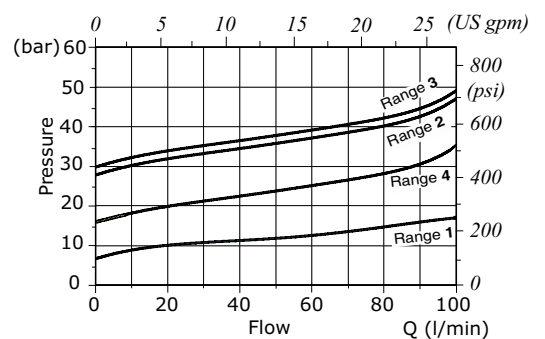

Rating diagrams

RP12W pressure reducing vs. control current

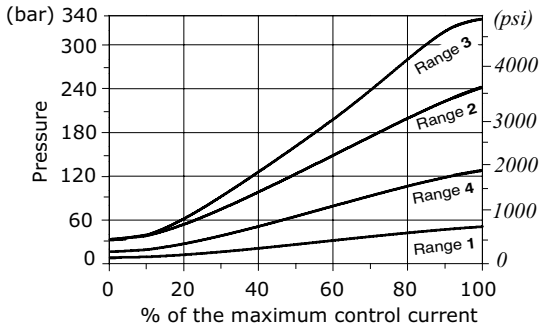

RP12W reducing/relieving pressure vs. flow

for % of control current - Pressure range 2 -

Relieving 1->3 Pressure reducing 2->1

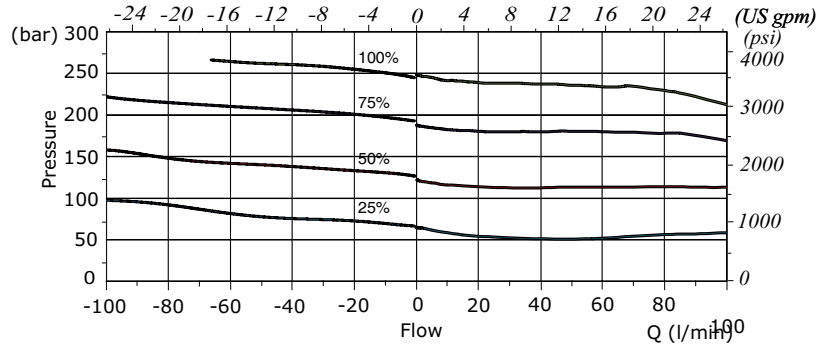

RP16W pressure drop vs. flow 2->1

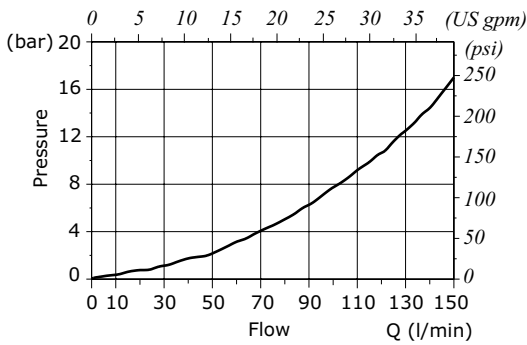

RP16W pressure drop vs. flow 1->3

with de-energized coil

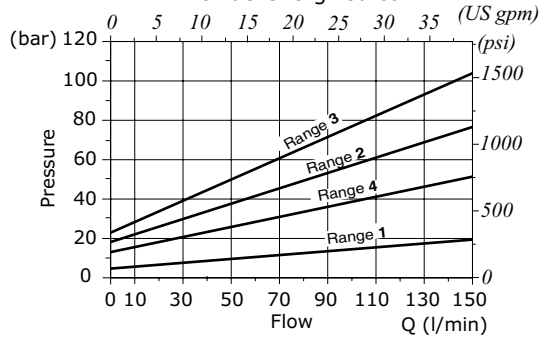

RP16W pressure reducing vs. control current

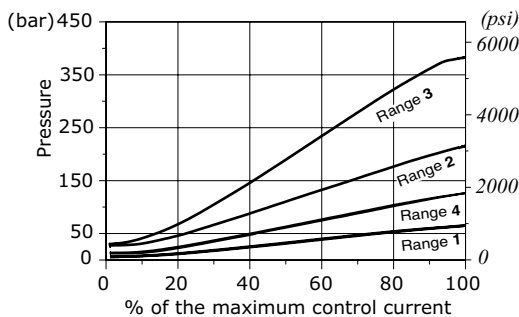

RP16W reducing/relieving pressure vs. flow

for % of control current - Pressure range 2 -

Relieving 1->3 Pressure reducing 2->1

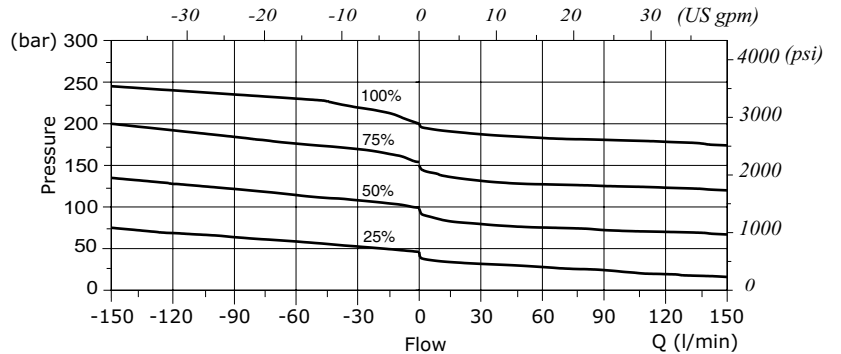



## RP08X type pressure reducing valves - 3 way

- Solenoid proportional type, pilot operated
- With relieving (NO)
- Spool type

Technical specifications and diagrams are measured with mineral oil of 46 cSt viscosity at 40°C (104°F) temperature.

RP08X		
Nominal flow		15 l/min (4 US gpm)
Max. pressure		350 bar (5100 psi)
Oil leakage		-
Fluid		mineral based oil
Viscosity		10-200 cSt
Max level of contamination		18/16/13 ISO4406
Fluid temperature	with NBR seals	from -20°C (-4°F) to 80°C (176°F)
	with FPM seals	from -20°C (-4°F) to 100°C (212°F)
Environmental temp. for working conditions		from -20°C (-4°F) to 50°C (122°F)
Cavity		SAE 08/3
Coil type*		BDP19
Nominal voltages		12 VDC - 24 VDC
Power rating		13 W (12 VDC) - 13.25 W (24 VDC)
Max control current		12 V -> 1.9 A - 24 V -> 0.9 A
Dither frequency		150 Hz
Hysteresis		≤4%
Weight		0.56 kg (1.23 lb)

NOTE - For different conditions, please contact Walvoil Sales Dpt. - For coils further features see from page 206.

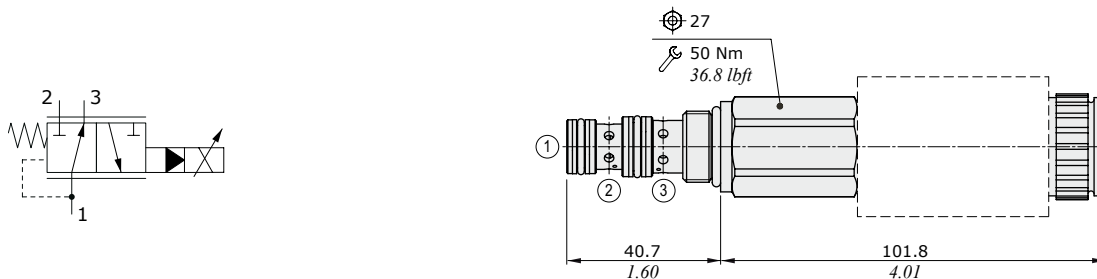

### Ordering codes and description composition

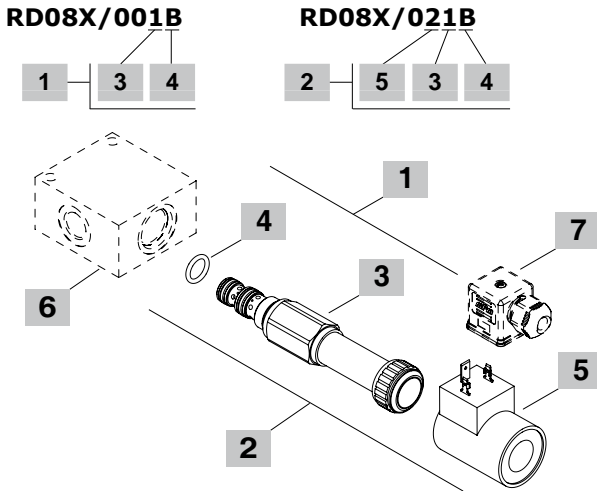

#### 1 Cartridges

TYPE	CODE	DESCRIPTION
<b>RP08X/001B</b>	ORP08002010	Pressure range <b>1</b>
<b>RP08X/002B</b>	ORP08002011	Pressure range <b>2</b>
<b>RP08X/003B</b>	ORP08002012	Pressure range <b>3</b>
<b>RP08X/004B</b>	ORP08002013	Pressure range <b>4</b>

#### 2 Complete cartridges

TYPE	CODE	DESCRIPTION
<b>RP08X/021B</b>	ORP08002007	Pressure range <b>1</b> , 12VDC
<b>RP08X/022B</b>	ORP08002001	Pressure range <b>2</b> , 12VDC
<b>RP08X/023B</b>	ORP08002002	Pressure range <b>3</b> , 12VDC
<b>RP08X/024B</b>	ORP08002003	Pressure range <b>4</b> , 12VDC

#### 3 Pressure range

TYPE	DESCRIPTION
<b>1</b>	Pressure range 10÷50 bar (145÷725 psi)
<b>2</b>	Pressure range 50÷200 bar (725÷2900 psi)
<b>3</b>	Pressure range 80÷350 bar (1160÷5075 psi)
<b>4</b>	Pressure range 20÷100 bar (290÷1450 psi)

#### 4 Seals

TYPE	DESCRIPTION
<b>B</b>	<b>NBR (Buna)</b> o-ring seals, std configuration
<b>V</b>	<b>FPM (Viton)</b> o-ring seals, contact Sales Dept.

#### 5 Coils

TYPE	CODE	DESCRIPTION
<b>2) BDP19 12VDC</b>	4SL5000120	12VDC-ISO4400 coil
<b>4) BDP19 24VDC</b>	4SL5000240	24VDC-ISO4400 coil

For complete coils list see page 206

#### 6 Valve body

TYPE	CODE	DESCRIPTION
<b>SAE 08/3-G 3/8</b>	3CC0830C11	Aluminium body for cavity 10 valve, G 3/8 std thread

Note: aluminium body can stand up to 210 bar (3050 psi)  
For steel bodies or different threading see from page 217

#### 7 Connector

TYPE	CODE	DESCRIPTION
<b>ISO4400</b>	4CN1009995	Connector

For complete connectors list see from page 206

### Rating diagram

Pressure drop vs. flow 2->1  
with de-energized coil

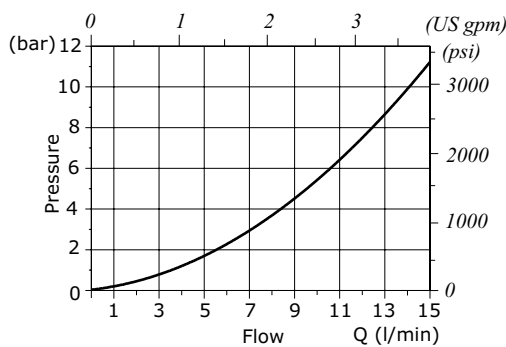

Pressure drop vs. flow 1->3

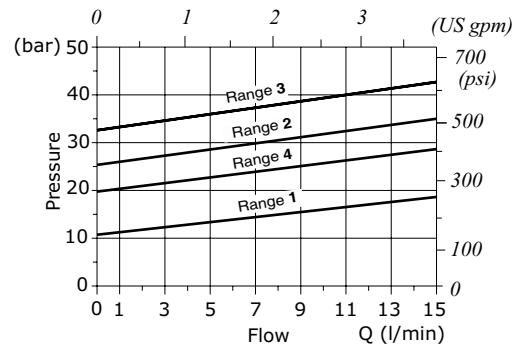

Pressure reducing vs. control current

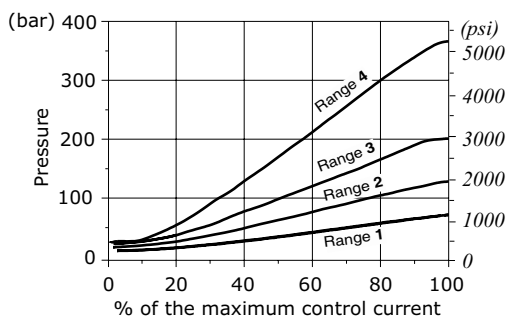

Reducing/relieving pressure vs. flow  
for % of control current - Pressure range 2

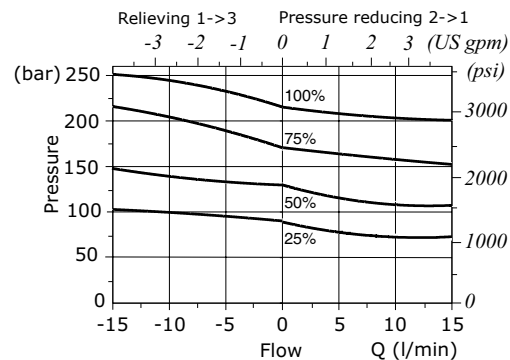



## SW..A type sequence valves - 2 way

- Pressure release type
- Pilot operated
- Spool type
- From SAE10 to SAE16 cavities

Technical specifications and diagrams are measured with mineral oil of 46 cSt viscosity at 40°C (104°F) temperature.

		SW10A	SW12D	SW16A
Nominal flow		60 l/min (16 US gpm)	100 l/min (26 US gpm)	180 l/min (48 US gpm)
Max. pressure		350 bar (5100 psi)		
Oil leakage	80% of max. pressure setting	22 cm <sup>3</sup> /min (1.34 in <sup>3</sup> /min)	50 cm <sup>3</sup> /min (3.05 in <sup>3</sup> /min)	100 cm <sup>3</sup> /min (6.1 in <sup>3</sup> /min)
Fluid		mineral based oil		
Viscosity		10-200 cSt		
Max level of contamination		20/18/14 ISO4406		
Fluid temperature	with NBR seals with FPM seals	from -20°C (-4°F) to 80°C (176°F) from -20°C (-4°F) to 100°C (212°F)		
Environmental temp. for working conditions		from -20°C (-4°F) to 50°C (122°F)		
Cavity		SAE 10/2	SAE 12/2	SAE 16/2
Weight		0.20 kg (0.44 lb)	0.30 kg (0.66 lb)	0.44 kg (0.97 lb)

NOTE - For different conditions, please contact Walvoil Sales Dpt.

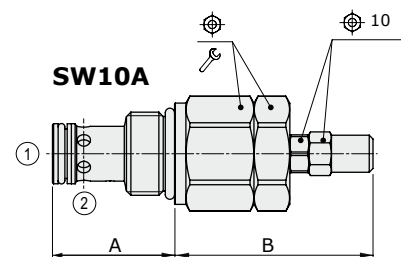
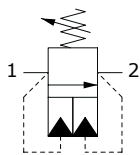

Valve type	A		B		⌀	Nm	lbft
	mm	in	mm	in			
SW10A	32.3	1.27	52.5	2.07	27	50	37
SW12D	46	1.81	52.5	2.07	32	80	59
SW16A	45.2	1.78	53	2.09	41	100	74

### Ordering codes and description composition

#### SW10A/OS2B

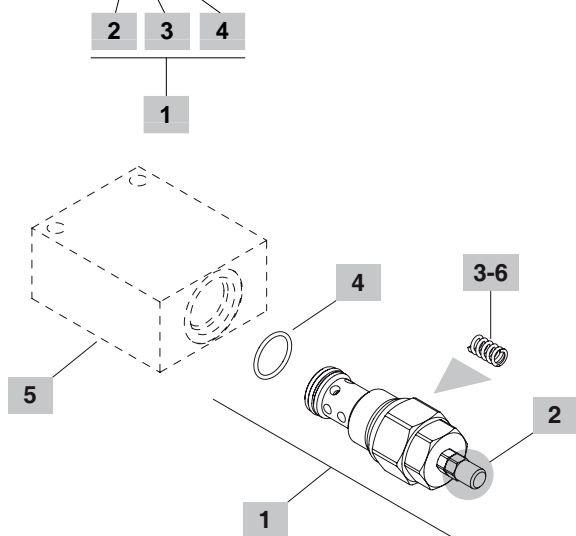

#### 1 Cartridges

TYPE	CODE	DESCRIPTION
<b>SAE cavity 10/2</b>		
SW10A/OS2B	OSW10002000	Pressure range 2
<b>SAE cavity 12/2</b>		
SW12D/OS2B	OSW12002005	Pressure range 2
<b>SAE cavity 16/2</b>		
SW16A/OS2B	OSW16002000	Pressure range 2

#### 2 Adjustments

TYPE	DESCRIPTION
S	Screw

#### 3 Pressure range

Standard setting is referred to at 5 l/min (1.32 US gpm) flow

TYPE	DESCRIPTION
1	Pressure range 10÷80 bar (145÷1160 psi); Std. setting 30 bar (435 psi), pressure increase by steps of 10 bar (145 psi) per screw turn
2	Pressure range 50÷220 bar (725÷3200 psi); Std. setting 150 bar (2200 psi), pressure increase by steps of 36 bar (520 psi) per screw turn
3	Pressure range 150÷350 bar (2200÷5100 psi); Std. setting 250 bar (3600 psi), pressure increase by steps of 90 bar (1300 psi) per screw turn

#### 4 Seals

TYPE	DESCRIPTION
B	<b>NBR (Buna)</b> o-ring seals, std configuration
V	<b>FPM (Viton)</b> o-ring seals, contact Sales Dept.

#### 5 Valve body

TYPE	CODE	DESCRIPTION
<b>SAE 10/2-G 3/8</b>	3CC1020C11	Aluminium body for cavity 10 valve, G 3/8 std thread
<b>SAE 12/2-G 1/2</b>	3CC1220D11	Aluminium body for cavity 12 valve, G 1/2 std thread
<b>SAE 16/2-G 3/4</b>	3CC1020C11	Aluminium body for cavity 16 valve, G 3/4 std thread

Note: aluminium body can stand up to 210 bar (3050 psi)  
For steel bodies or different threading see from page 215

#### 6 Springs

TYPE	CODE	DESCRIPTION
1	3ML1081400	Pressure range 1 - white band
2	3ML1081401	Pressure range 2 - no band
3	3ML1081402	Pressure range 3 - red band

### Rating diagrams

#### SW10A pressure vs. flow

std. setting at 5 l/min (1.32 US gpm)

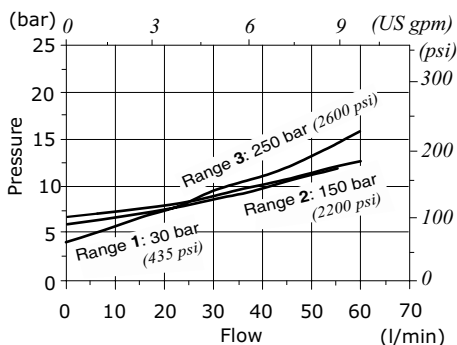

#### SW12A pressure vs. flow

std. setting at 5 l/min (1.32 US gpm)

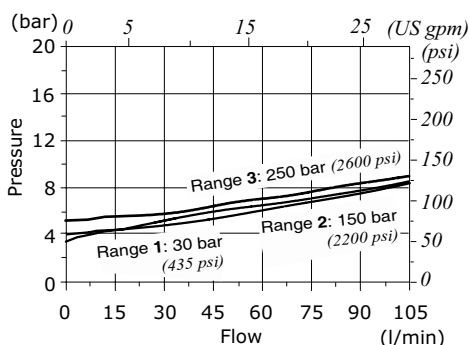

#### SW16A pressure vs. flow

std. setting at 5 l/min (1.32 US gpm)

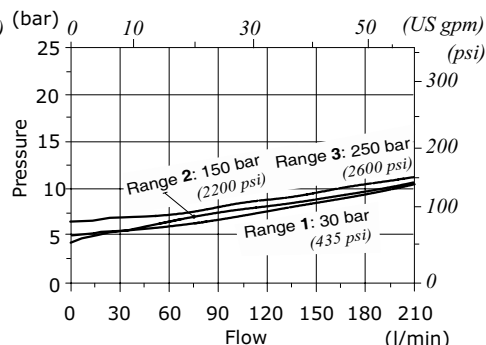





## SE..A type sequence valves - 3 way

- Direct acting
- External pilot
- Poppet type
- From SAE08 to SAE10 cavities

Technical specifications and diagrams are measured with mineral oil of 46 cSt viscosity at 40°C (104°F) temperature.

	SE08A	SE10A
Nominal flow	5 l/min (1.32 US gpm)	20 l/min (5.3 US gpm)
Max. pressure	210 bar (3050 psi)	
Oil leakage	80% of max. pressure setting	0.25 cm <sup>3</sup> /min (0.015 in <sup>3</sup> /min)
Fluid	mineral based oil	
Viscosity	10-200 cSt	
Max level of contamination	20/18/14 ISO4406	
Fluid temperature	with NBR seals with FPM seals	from -20°C (-4°F) to 80°C (176°F) from -20°C (-4°F) to 100°C (212°F)
Environmental temp. for working conditions	from -20°C (-4°F) to 50°C (122°F)	
Cavity	SAE 08/3	SAE 10/3
Weight	0.28 kg (0.62 lb)	0.47 kg (1.04 lb)

NOTE - For different conditions, please contact Walvoil Sales Dpt.

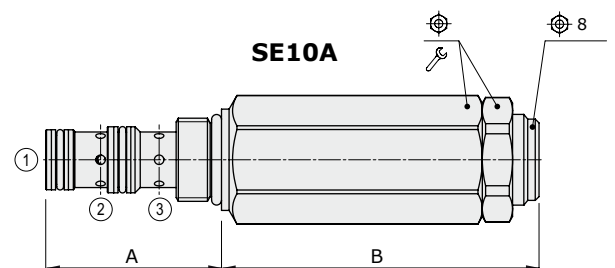
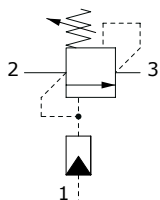

Valve type	A		B		⌀	Nm	lbft
	mm	in	mm	in			
SE08A	41	1.61	69	2.72	27	30	22
SE10A	47	1.85	95	3.74	30	50	37

### Ordering codes and description composition

#### SE08A/1S1B

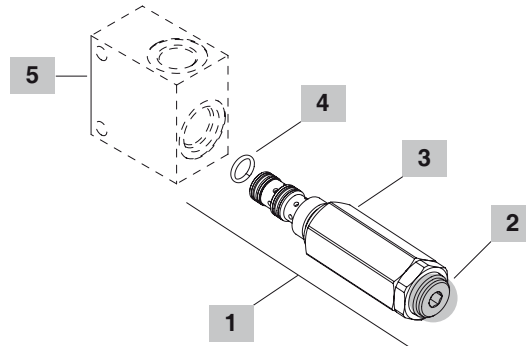
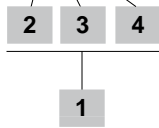

#### 1 Cartridges

TYPE	CODE	DESCRIPTION
<b>SAE cavity 08/3</b>		
SE08A/1S1B	OSE08002003	With pressure range 1
SE08A/1S2B	OSE08002002	With pressure range 2
SE08A/1S3B	OSE08002001	With pressure range 3
SE08A/1S4B	OSE08002000	With pressure range 4
<b>SAE cavity 10/3</b>		
SE10A/1S1B	OSE10002001	With pressure range 1
SE10A/1S2B	OSE10002002	With pressure range 2
SE10A/1S3B	OSE10002000	With pressure range 3
SE10A/1S4B	OSE10002003	With pressure range 4

#### 2 Adjustments

TYPE	DESCRIPTION
S	Screw

#### 3 Pressure settings

Standard setting is referred to at 1 l/min (0.26 US gpm) flow

TYPE	DESCRIPTION
1	Range 5÷50 bar (72.5÷725 psi); Std. setting 30 bar (435 psi)
2	Range 20÷100 bar (290÷1450 psi); Std. setting 50 bar (725 psi)
3	Range 50÷150 bar (725÷2175 psi); Std. setting 100 bar (1450 psi)
4	Range 100÷250 bar (1450÷3600 psi); Std. setting 180 bar (2600 psi)

#### 4 Seals

TYPE	DESCRIPTION
B	NBR (Buna) o-ring seals, std configuration
V	FPM (Viton) o-ring seals, contact Sales Dept.

#### 5 Valve body

TYPE	CODE	DESCRIPTION
SAE 08/3-G 1/4	3CC0830B11	Aluminium body for cavity 08 valve, G 1/4 std thread
SAE 10/3-G 3/8	3CC1030C11	Aluminium body for cavity 10 valve, G 3/8 std thread

For steel bodies or different threading see from page 217

### Rating diagrams

SE08A pressure drop vs. flow 2->3

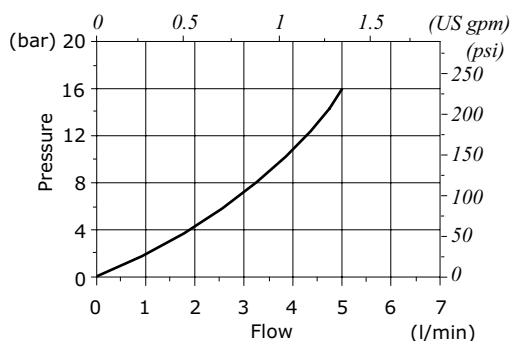

SE10A pressure drop vs. flow 2->3

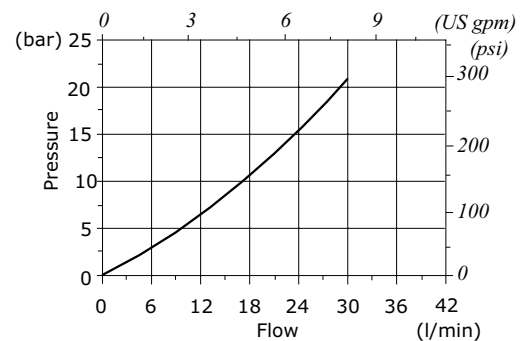



## SP10A type sequence valve - 3 way

- Pilot operated
- Spool type
- Not affected by back pressure

Technical specifications and diagrams are measured with mineral oil of 46 cSt viscosity at 40°C (104°F) temperature.

### SP10A

Nominal flow		50 l/min (13 US gpm)
Max. pressure		350 bar (5100 psi)
Oil leakage	at 210 bar (3050 psi)	25 cm <sup>3</sup> /min (1.52 in <sup>3</sup> /min)
Fluid		mineral based oil
Viscosity		10-200 cSt
Max level of contamination		20/18/14 ISO4406
Fluid temperature	with NBR seals with FPM seals	from -20°C (-4°F) to 80°C (176°F) from -20°C (-4°F) to 100°C (212°F)
Environmental temp. for working conditions		from -20°C (-4°F) to 50°C (122°F)
Cavity		SAE 10/3
Weight		0.21 kg (0.46 lb)

NOTE - For different conditions, please contact Walvoil Sales Dpt.

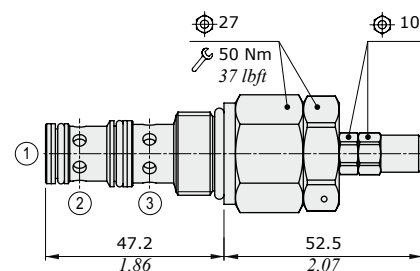
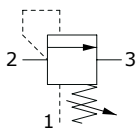

## Ordering codes and description composition

### SP10A/1S3B

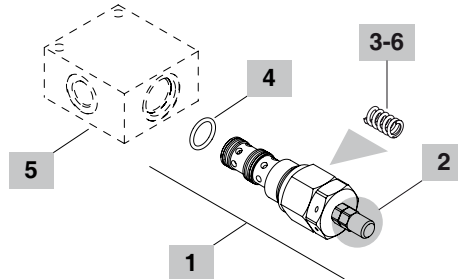
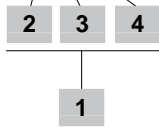

#### 1 Cartridges

TYPE	CODE	DESCRIPTION
<b>SAE cavity 10/3</b>		
SP10A/1S3B	OSP10002001	Pressure range 3

#### 2 Adjustments

TYPE	DESCRIPTION
S	Screw

#### 3 Pressure range

Standard setting is referred to at 5 l/min (1.32 US gpm) flow

TYPE	DESCRIPTION
1	Pressure range 10÷80 bar (145÷1150 psi); Std. setting 20 bar (290 psi), pressure increase by steps of 10 bar (145 psi) per screw turn
2	Pressure range 50÷220 bar (725÷3200 psi); Std. setting 150 bar (2175 psi), pressure increase by steps of 46 bar (660 psi) per screw turn
3	Pressure range 150÷350 bar (2200÷5100 psi); Std. setting 250 bar (3600 psi), pressure increase by steps of 110 bar (1600 psi) per screw turn

#### 4 Seals

TYPE	DESCRIPTION
B	<b>NBR (Buna)</b> o-ring seals, std configuration
V	<b>FPM (Viton)</b> o-ring seals, contact Sales Dept.

#### 5 Valve body

TYPE	CODE	DESCRIPTION
SAE 10/3-G 3/8	3CC1030C11	Aluminium body for cavity 10 valve, G 3/8 std thread

Note: aluminium body can stand up to 210 bar (3050 psi)  
For steel bodies or different threading see from page 217

#### 6 Springs

TYPE	CODE	DESCRIPTION
1	3ML1081400	Pressure range 1 - white band
2	3ML1081401	Pressure range 2 - no band
3	3ML1081402	Pressure range 3 - red band

## Rating diagrams

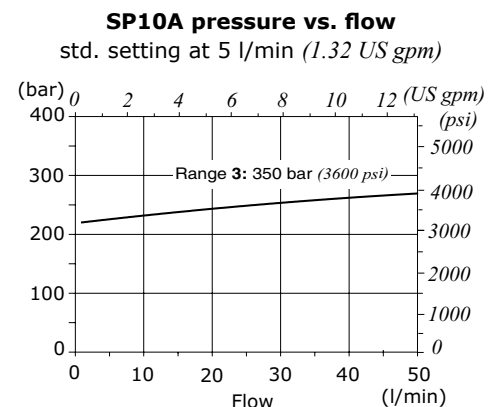
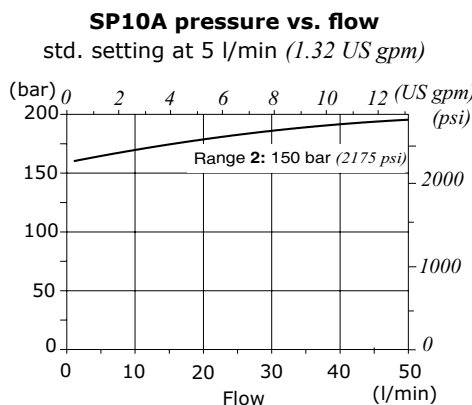
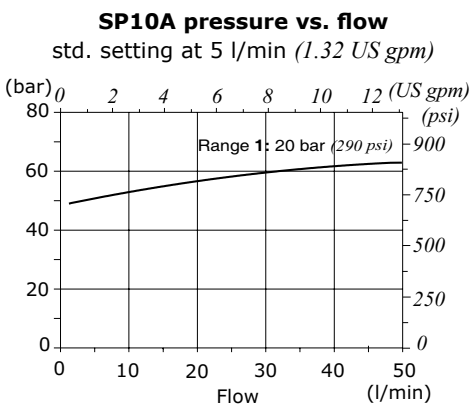



## SG12A type sequence valve - 4 way

- Direct acting
- Poppet type
- External pilot and drain

Technical specifications and diagrams are measured with mineral oil of 46 cSt viscosity at 40°C (104°F) temperature.

### SG12A

Nominal flow		50 l/min (13 US gpm)
Max. pressure		300 bar (4350 psi)
Oil leakage		-
Fluid		mineral based oil
Viscosity		10-200 cSt
Max level of contamination		20/18/14 ISO4406
Fluid temperature	with NBR seals	from -20°C (-4°F) to 80°C (176°F)
	with FPM seals	from -20°C (-4°F) to 100°C (212°F)
Environmental temp. for working conditions		from -20°C (-4°F) to 50°C (122°F)
Cavity		SAE 12/4
Weight		0.52 kg (1.15 lb)

NOTE - For different conditions, please contact Walvoil Sales Dpt.

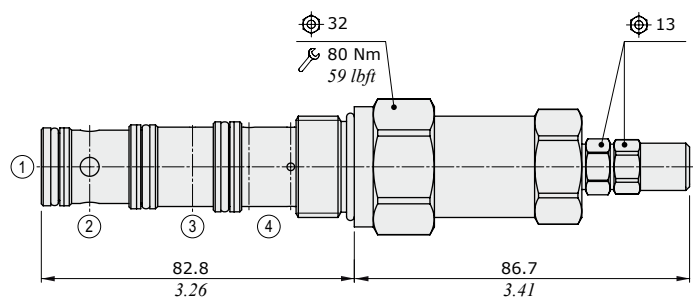
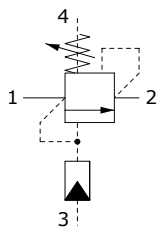

## Ordering codes and description composition

### SG12A/1S1B

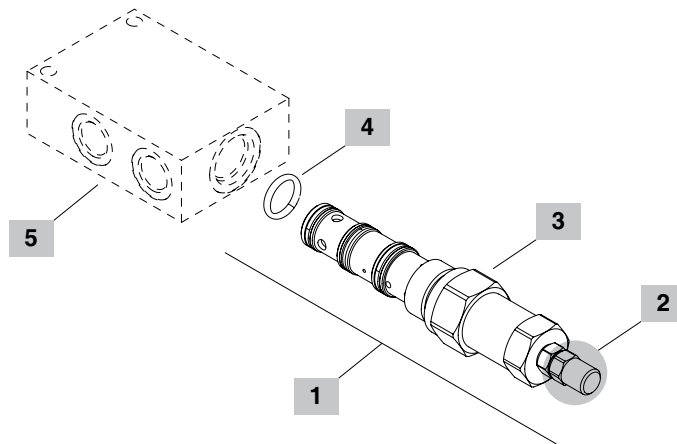
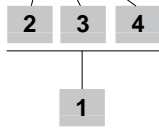

#### 1 Cartridges

TYPE	CODE	DESCRIPTION
<b>SAE cavity 12/4</b>		
<b>SG12A/1S1B</b>	OSG12002000	Cartridge pres. sett. <b>1</b>
<b>SG12A/1S2B</b>	OSG12002002	Cartridge pres. sett. <b>2</b>
<b>SG12A/1S3B</b>	OSG12002001	Cartridge pres. sett. <b>3</b>

#### 2 Adjustments

TYPE	DESCRIPTION
<b>S</b>	Screw

#### 3 Pressure settings

Standard setting is referred to at 1 l/min (0.26 US gpm) flow

TYPE	DESCRIPTION
<b>1</b>	Range 20÷100 bar (290÷1450 psi); Std. setting 50 bar (725 psi)
<b>2</b>	Range 50÷200 bar (725÷2900 psi); Std. setting 150 bar (2200 psi)
<b>3</b>	Range 100÷300 bar (1450÷4350 psi); Std. setting 250 bar (3600 psi)

#### 4 Seals

TYPE	DESCRIPTION
<b>B</b>	<b>NBR (Buna)</b> o-ring seals, std configuration
<b>V</b>	<b>FPM (Viton)</b> o-ring seals, contact Sales Dept.

#### 5 Valve body

TYPE	CODE	DESCRIPTION
<b>SAE 12/4-G 1/2</b>	3CC1240D11	Aluminium body for cavity 12 valve, G 1/2 std thread

Note: aluminium body can stand up to 210 bar (3050 psi)  
For steel bodies or different threading see from page 219

## Rating diagrams

SG12A pressure drop vs. flow 1->2

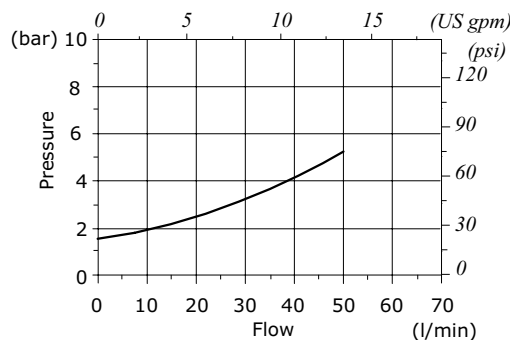



## UC..A type check valves - 2 way

- Poppet type
- From SAE08 to SAE16 cavities

Technical specifications and diagrams are measured with mineral oil of 46 cSt viscosity at 40°C (104°F) temperature.

	UC08A	UC10A	UC12A	UC16A
Nominal flow	up to 20 l/min (5.3 US gpm)	up to 35 l/min (9.2 US gpm)	up to 50 l/min (13 US gpm)	up to 100 l/min (26 US gpm)
Max. pressure	350 bar (5100 psi)			
Oil leakage	at 100 bar (1450 psi)	0.25 cm <sup>3</sup> /min (0.015 in <sup>3</sup> /min)	0.25 cm <sup>3</sup> /min (0.015 in <sup>3</sup> /min)	0.25 cm <sup>3</sup> /min (0.015 in <sup>3</sup> /min)
Fluid	mineral based oil			
Viscosity	10-200 cSt			
Max level of contamination	20/18/14 ISO4406			
Fluid temperature	with NBR seals with FPM seals	from -20°C (-4°F) to 80°C (176°F) from -20°C (-4°F) to 100°C (212°F)		
Environmental temp. for working conditions	from -20°C (-4°F) to 50°C (122°F)			
Cavity	SAE 08/2	SAE 10/2	SAE 12/2	SAE 16/2
Weight	0.080 kg (0.18 lb)	0.090 kg (0.20 lb)	0.180 kg (0.40 lb)	0.370 kg (0.81 lb)

NOTE - For different conditions, please contact Walvoil Sales Dpt.

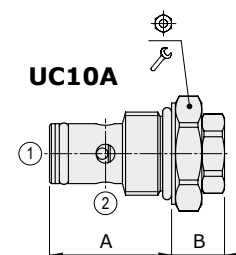

Valve type	A		B				Nm	lbft
	mm	in	mm	in				
UC08A	27.6	1.09	15.5	0.61	24	30	22	
UC10A	32.3	1.27	12.5	0.49	27	50	37	
UC12A	46	1.81	14	0.55	32	80	59	
UC16A	45.2	1.78	25	0.98	41	100	73	

## Ordering codes and description composition

### UC08A/001B

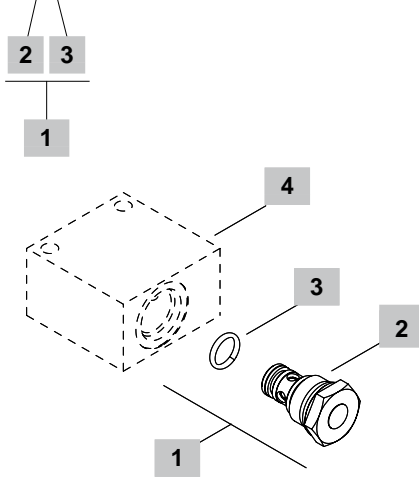

### 2 Opening pressure from 1 to 2

TYPE	DESCRIPTION
1	0.5 bar (7.3 psi)
2	2.5 bar (36.2 psi)
3	5 bar (72.5 psi)

### 3 Seals

TYPE	DESCRIPTION
B	<b>NBR (Buna)</b> Std configuration without addition
V	For valve with <b>FPM (Viton)</b> o-ring seals, contact Sales Dpt.

### 4 Valve body

TYPE	CODE	DESCRIPTION
<b>SAE 08/2-G 3/8</b>	3CC0820C11	Aluminium body for cavity 08 valve, G3/8 std thread
<b>SAE 10/2-G 3/8</b>	3CC1020C11	Aluminium body for cavity 10 valve, G3/8 std thread
<b>SAE 12/2-G 1/2</b>	3CC1220D11	Aluminium body for cavity 12 valve, G1/2 std thread
<b>SAE 16/2-G 3/4</b>	3CC1620E11	Aluminium body for cavity 16 valve, G3/4 std thread

Note: aluminium body can stand up to 210 bar (3050 psi)  
For steel bodies or different threading see from page 215

### 1 Cartridges

TYPE	CODE	DESCRIPTION
<b>SAE cavity 08/2</b>		
<b>UC08A/001B</b>	0UC08002001	Opening pressure 0.5 bar (7.3 psi)
<b>SAE cavity 10/2</b>		
<b>UC10A/001B</b>	0UC10002000	Opening pressure 0.5 bar (7.3 psi)
<b>SAE cavity 12/2</b>		
<b>UC12A/001B</b>	0UC12002000	Opening pressure 0.5 bar (7.3 psi)
<b>SAE cavity 16/2</b>		
<b>UC16A/001B</b>	0UC16002001	Opening pressure 0.5 bar (7.3 psi)

## Rating diagrams

UC08A pressure drop vs flow

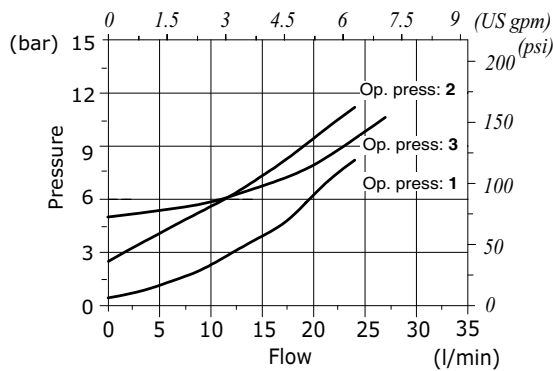

UC10A pressure drop vs flow

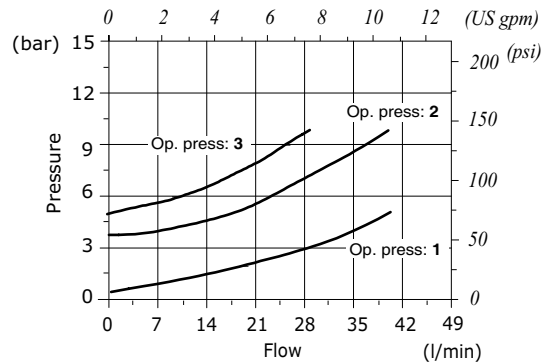

UC12A pressure drop vs flow

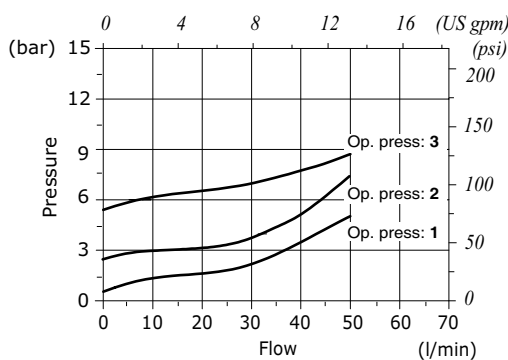

UC16A pressure drop vs flow

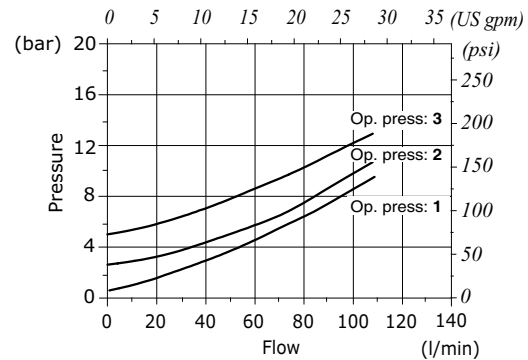





## UT..A type shuttle valves - 3 way

- Shuttle valve
- Poppet type
- From SAE08 to SAE10 cavities

Technical specifications and diagrams are measured with mineral oil of 46 cSt viscosity at 40°C (104°F) temperature.

	UT08A	UT10A
Nominal flow	15 l/min (4 US gpm)	up to 20 l/min (5.3 US gpm)
Max. pressure	350 bar (5100 psi)	
Oil leakage	-	
Fluid	mineral based oil	
Viscosity	10-200 cSt	
Max level of contamination	20/18/14 ISO4406	
Fluid temperature	with NBR seals with FPM seals	from -20°C (-4°F) to 80°C (176°F) from -20°C (-4°F) to 100°C (212°F)
Environmental temp. for working conditions	from -20°C (-4°F) to 50°C (122°F)	
Cavity	SAE 08/3	SAE 10/3
Weight	0.080 kg (0.18 lb)	0.100 kg (0.22 lb)

NOTE - For different conditions, please contact Walvoil Sales Dpt.

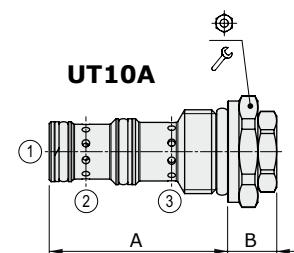
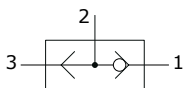

Valve type	A		B		Torque symbol	Nm	lbft
	mm	in	mm	in			
UT08A	40.8	1.60	12.5	0.49	24	30	22
UT10A	47.2	1.86	13	0.51	27	50	36

## Ordering codes and description composition

UT08A/000B

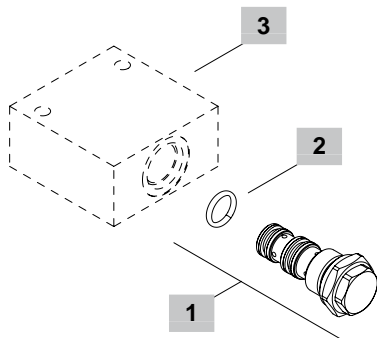

### 1 Cartridges

TYPE	CODE	DESCRIPTION
<b>SAE cavity 08/3</b>		
UT08A/000B	0UT08002000	Valve assembly
<b>SAE cavity 10/3</b>		
UT10A/000B	0UT10002000	Valve assembly

### 2 Seals

TYPE	DESCRIPTION
<b>B</b>	<b>NBR (Buna)</b> Std configuration without addition
<b>V</b>	For valve with <b>FPM (Viton)</b> o-ring seals, contact Sales Dept.

### 3 Valve body

TYPE	CODE	DESCRIPTION
<b>SAE 08/3-G 1/4</b>	3CC0830B11	Aluminium body for cavity 08 valve, G1/4 std thread
<b>SAE 10/3-G 3/8</b>	3CC1030C11	Aluminium body for cavity 10 valve, G3/8 std thread

Note: aluminium body can stand up to 210 bar (3050 psi)  
For steel bodies or different threading see from page 217

## Rating diagrams

UT08A pressure drop vs flow

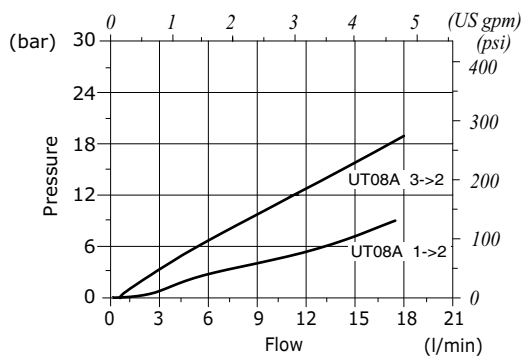

UT10A pressure drop vs flow

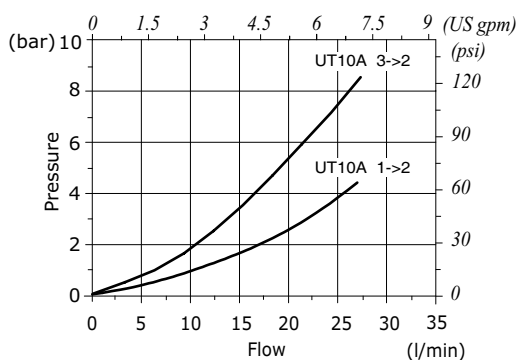



## BC... type pilot operated check valves - 3 way

- Poppet type
- From SAE08 to SAE10 cavities

Technical specifications and diagrams are measured with mineral oil of 46 cSt viscosity at 40°C (104°F) temperature.

	<b>BC08A</b>	<b>BC10A-B</b>	<b>BC10C</b>	<b>BC12A-B</b>	<b>BC16A-B</b>
Nominal flow	15 l/min (4 US gpm)	30 l/min (8 US gpm)	60 l/min (16 US gpm)	50 l/min (13 US gpm)	100 l/min (26 US gpm)
Max. pressure	350 bar (5100 psi)				
Oil leakage	at 100 bar (1450 psi)	0.25 cm <sup>3</sup> /min (0.015 in <sup>3</sup> /min)	0.25 cm <sup>3</sup> /min (0.015 in <sup>3</sup> /min)	0.25 cm <sup>3</sup> /min (0.015 in <sup>3</sup> /min)	0.25 cm <sup>3</sup> /min (0.015 in <sup>3</sup> /min)
Fluid	mineral based oil				
Viscosity	10-200 cSt				
Max level of contamination	20/18/14 ISO4406				
Fluid temperature	with NBR seals		from -20°C (-4°F) to 80°C (176°F)		
	with FPM seals		from -20°C (-4°F) to 100°C (212°F)		
Environmental temp. for working conditions	from -20°C (-4°F) to 50°C (122°F)				
Cavity	SAE 08/3	SAE 10/3	SAE 10/3	SAE 12/3	SAE 16/3
Weight	0.080 kg (0.18 lb)	0.100 kg (0.22 lb)	0.111 kg (0.24 lb)	0.230 kg (0.51 lb)	0.440 kg (0.97 lb)

NOTE - For different conditions, please contact Walvoil Sales Dpt.

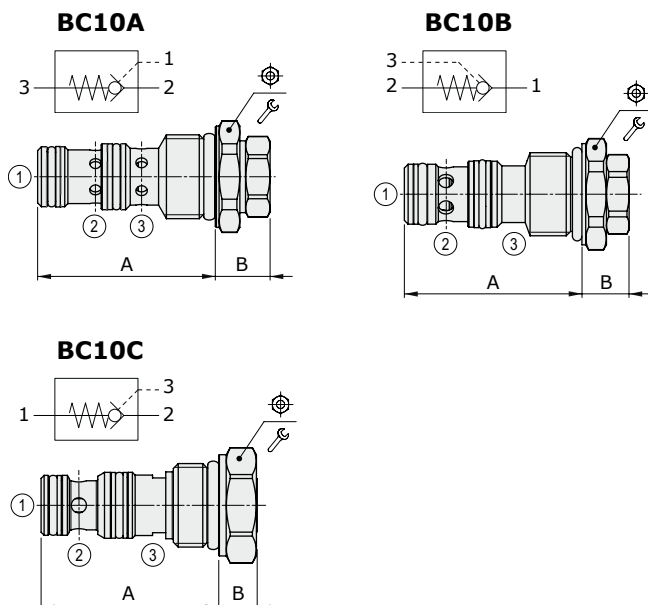

Valve type	A		B					
	mm	in	mm	in				
BC..A	SAE 08/3	40.8	1.61	15.5	0.61	24	30	22
	SAE 10/3	47	1.85	11	0.43	27	50	36
	SAE 12/3	73.5	2.89	14	0.55	32	80	59
	SAE 16/3	75.4	2.97	25	0.98	41	100	73
BC..B	SAE 10/3	47	1.85	6.5	0.25	27	50	36
	SAE 12/3	73.5	2.89	14	0.55	32	80	59
	SAE 16/3	99	3.90	24	0.94	41	100	73
BC..C	SAE 10/3	47	1.85	10.2	0.40	27	50	36

## Ordering codes and description composition

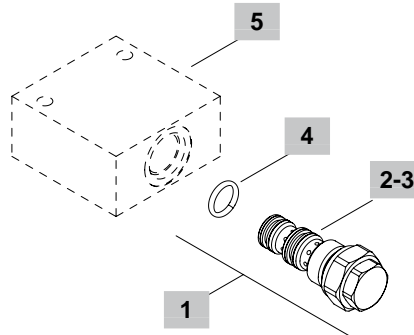
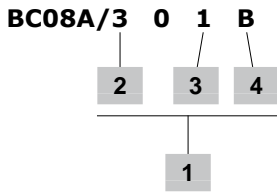

### 1 Cartridges

TYPE	CODE	DESCRIPTION
<b>SAE cavity 08/3</b>		
BC08A/301B	OBC08002000	Pilot ratio 1:2.5 Opening press. 2 to 3 = 5 bar (72.5 psi)
<b>SAE cavity 10/3</b>		
BC10A/301B	OBC10002001	Pilot ratio 1:3 Opening press. 2 to 3 = 5 bar (72.5 psi)
BC10B/301B	OBC10002008	Pilot ratio 1:2 Opening press. 1 to 2 = 5 bar (72.5 psi)
BC10C/401B	OBC10002011	Pilot ratio 1:4 Opening press. 2 to 1 = 5 bar (72.5 psi)
<b>SAE cavity 12/3</b>		
BC12A/301B	OBC12002000	Pilot ratio 1:3 Opening press. 2 to 3 = 5 bar (72.5 psi)
BC12B/301B	OBC12002005	Pilot ratio 1:3 Opening press. 1 to 2 = 5 bar (72.5 psi)
<b>SAE cavity 16/3</b>		
BC16A/301B	OBC16002000	Pilot ratio 1:2.5 Opening press. 2 to 3 = 5 bar (72.5 psi)
BC16B/301B	OBC16002004	Pilot ratio 1:2.5 Opening press. 1 to 2 = 5 bar (72.5 psi)

### 2 Pilot ratio

TYPE	DESCRIPTION
<b>For BC..A</b>	
BC08A/3	1:2.5
BC10A/3	1:3
BC12A/3	1:3
BC16A/3	1:2.5
<b>For BC..B</b>	
BC10B/3	1:2
BC12B/3	1:3
BC16B/3	1:2.5
<b>For BC..C</b>	
BC10B/3	1:4

### 3 Opening pressure from 2 to 3

TYPE	DESCRIPTION
<b>For BC..A from 2 to 3</b>	
1	5 bar (72.5 psi) with sealed piston
2	2.5 bar (36.2 psi) without sealed piston
<b>For BC..B from 1 to 2</b>	
1	5 bar (72.5 psi) with sealed piston
<b>For BC..C from 2 to 1</b>	
1	5 bar (72.5 psi) with seal

### 4 Seals

TYPE	DESCRIPTION
B	<b>NBR (Buna)</b> Std configuration without addition
V	For valve with <b>FPM (Viton)</b> o-ring seals, contact Sales Dept.

### 5 Valve body

TYPE	CODE	DESCRIPTION
<b>SAE 08/3-G 3/8</b>	3CC0830C11	Aluminium body for cavity 08 valve, G3/8 std thread
<b>SAE 10/3-G 3/8</b>	3CC1030C11	Aluminium body for cavity 10 valve, G3/8 std thread
<b>SAE 12/3-G 3/8</b>	3CC1230D11	Aluminium body for cavity 12 valve, G1/2 std thread
<b>SAE 16/3-G 3/8</b>	3CC1630E11	Aluminium body for cavity 16 valve, G3/4 std thread

Note: aluminium body can stand up to 210 bar (3050 psi)  
For steel bodies or different threading see from page 217

**Rating diagrams**

**BC08A pressure drop vs flow**

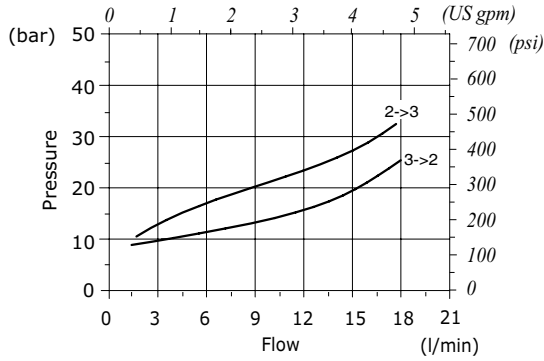

**BC10A pressure drop vs flow**

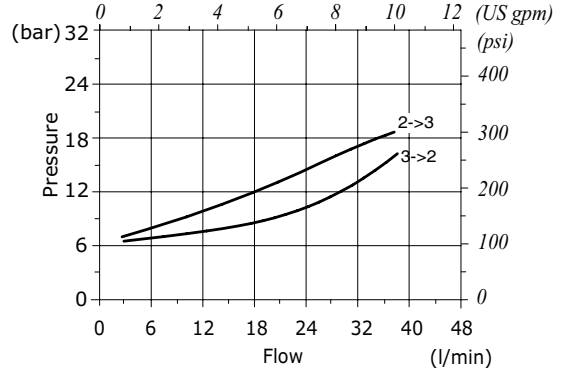

**BC12A pressure drop vs flow**

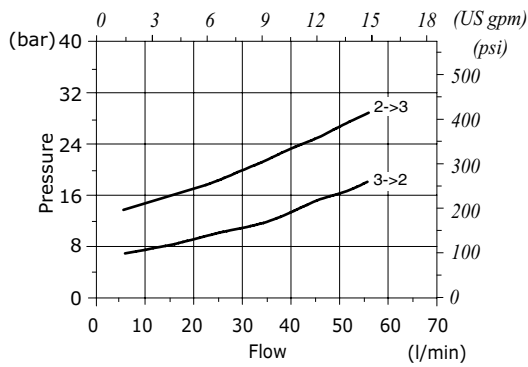

**BC16A pressure drop vs flow**

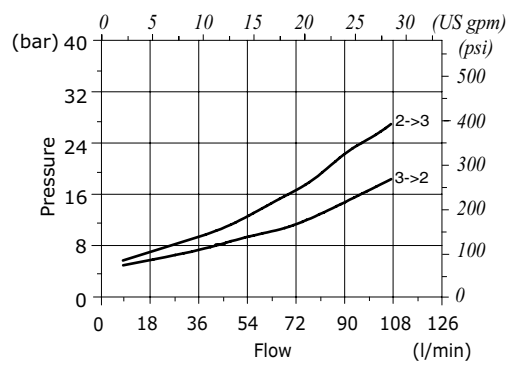

**BC10B pressure drop vs flow**

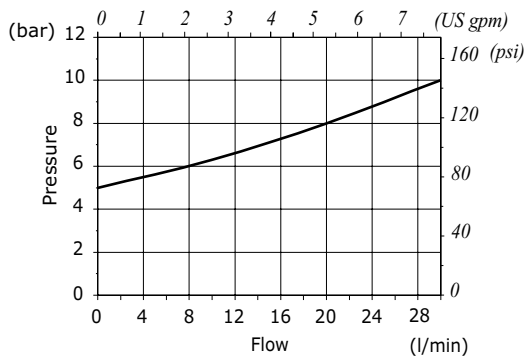

**BC12B pressure drop vs flow**

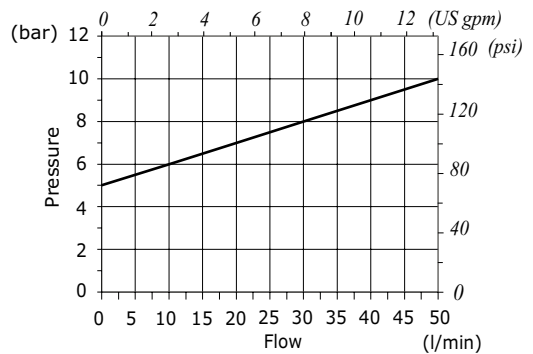

## Rating diagrams

**BC16B pressure drop vs flow**

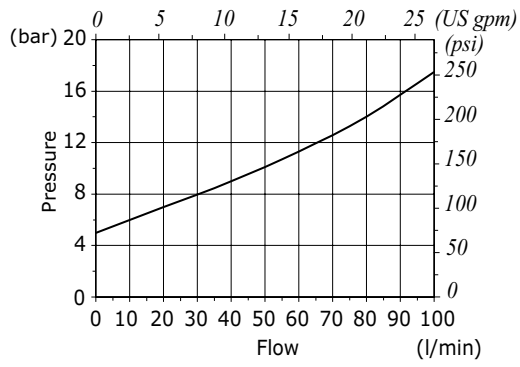

**BC10C pressure drop vs flow**

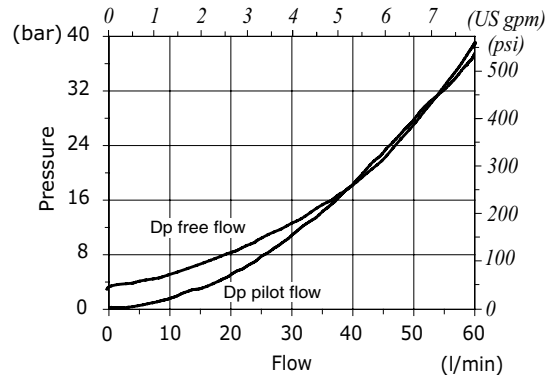



## CA..A type counterbalance valves - 3 way

- For open center
- Line mounting
- From SAE10 to SAE16 cavities

Technical specifications and diagrams are measured with mineral oil of 46 cSt viscosity at 40°C (104°F) temperature.

	CA10A	CA12A	CA16A
Nominal flow	30 l/min (7.9 US gpm)	60 l/min (16 US gpm)	90 l/min (23.8 US gpm)
Max. pressure	350 bar (5100 psi)		
Oil leakage	80% of max. pressure setting	0.25 cm <sup>3</sup> /min (0.015 in <sup>3</sup> /min)	0.25 cm <sup>3</sup> /min (0.015 in <sup>3</sup> /min)
Fluid	mineral based oil		
Viscosity	10-200 cSt		
Max level of contamination	20/18/14 ISO4406		
Fluid temperature	with NBR seals with FPM seals	from -20°C (-4°F) to 80°C (176°F) from -20°C (-4°F) to 100°C (212°F)	
Environmental temp. for working conditions	from -20°C (-4°F) to 50°C (122°F)		
Cavity	SAE 10/3	SAE 12/3	SAE 16/3
Weight	0.280 kg (0.62 lb)	0.280 kg (0.62 lb)	0.670 kg (1.48 lb)

NOTE - For different conditions, please contact Walvoil Sales Dpt.

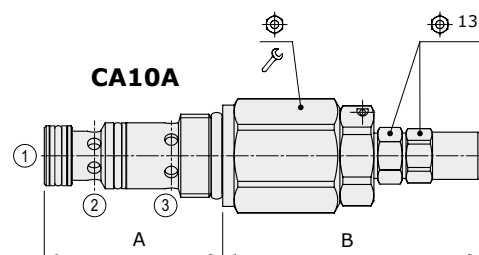
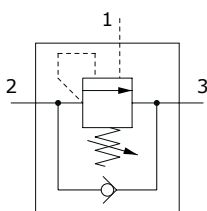

Valve type	A		B			Nm	lbft	
	mm	in	mm	in				
CA10A/	4S	47.2	1.86	68.5	2.70	27	50	37
	4W	47.2	1.86	68.5	2.70	27	50	37
CA12A/	4S	73.5	2.89	62.5	2.46	32	80	59
	4W	73.5	2.89	62.5	2.46	32	80	59
CA16A/	4S	75	2.95	69.9	2.74	41	100	74
	4W	75	2.95	69.9	2.74	41	100	74

### Ordering codes and description composition

#### CA10A/4S2B

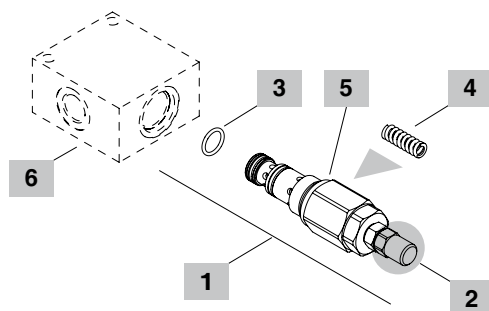
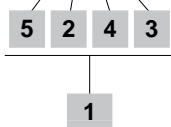

#### 1 Cartridges

TYPE	CODE	DESCRIPTION
<b>SAE cavity 10/3</b>		
CA10A/4S2B	0CA10002007	Screw type adjustment, pilot ratio 1:4 pressure range <b>2</b>
<b>SAE cavity 12/3</b>		
CA12A/4S2B	0CA12002000	Screw type adjustment, pilot ratio 1:4 pressure range <b>2</b>
<b>SAE cavity 16/3</b>		
CA16A/4S2B	0CA16002001	Screw type adjustment, pilot ratio 1:4 pressure range <b>2</b>

#### 2 Adjustments

TYPE	DESCRIPTION
<b>S</b>	Screw
<b>W</b>	Copped adjustment

#### 3 Seals

TYPE	DESCRIPTION
<b>B</b>	<b>NBR (Buna)</b> Std configuration without addition
<b>V</b>	For valve with <b>FPM (Viton)</b> o-ring seals, contact Sales Dept.

#### 4 Pressure range

Standard setting is referred to 5 l/min (1.32 US gpm) flow

TYPE	CODE	DESCRIPTION
<b>For CA10A valve</b>		
<b>1</b>	3ML1092502 red band	Setting range 50-220 bar (725-3200 psi)
<b>2</b>	3ML1092300 red band	Setting range 180-350 bar (2600-5100 psi)
<b>3</b>	3ML1102800 red band	Setting range 300-700 bar (4350-10150 psi)
<b>For CA12A valve</b>		
<b>1</b>	3ML1133201 blue band	Setting range 50-220 bar (725-3200 psi)
<b>2</b>	3ML1133200 red band	Setting range 180-350 bar (2600-5100 psi)
<b>3</b>	3ML1133500 yellow band	Setting range 300-700 bar (4350-10150 psi)
<b>For CA16A valve</b>		
<b>1</b>	3ML1164000 blue band	Setting range 50-220 bar (725-3200 psi)
<b>2</b>	3ML1164001 red band	Setting range 180-350 bar (2600-5100 psi)
<b>3</b>	3ML1164002 yellow band	Setting range 300-700 bar (4350-10150 psi)

#### 5 Pilot ratio

TYPE	DESCRIPTION
<b>4</b>	1:4

#### 6 Valve body

TYPE	CODE	DESCRIPTION
<b>SAE 10/3-G 3/8</b>	3CC1030C11	Aluminium body for cavity 10, valve G3/8 std thread
<b>SAE 12/3-G 1/2</b>	3CC1230D11	Aluminium body for cavity 12 valve, G1/2 std thread
<b>SAE 16/3-G 3/4</b>	3CC1630E11	Aluminium body for cavity 16 valve, G3/4 std thread

Note: aluminium body can stand up to 210 bar (3050 psi)  
For steel bodies or different threading see from page 217



**Rating diagrams**

**CA10A pressure drop vs flow**

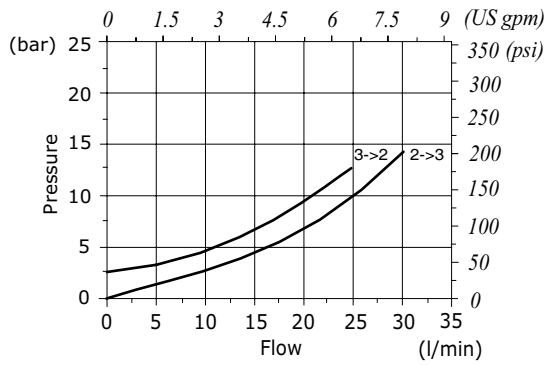

**CA12A pressure drop vs flow**

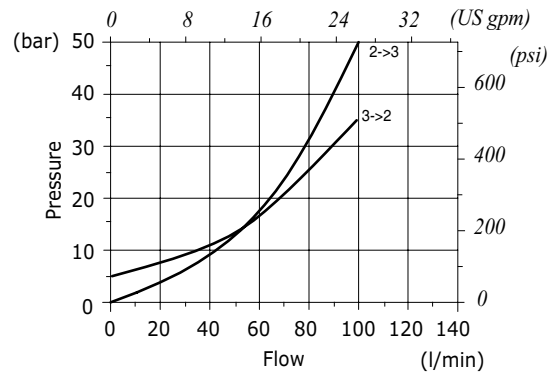

**CA16A pressure drop vs flow**

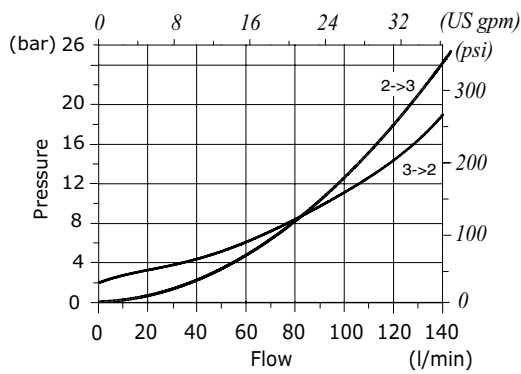





## CC..A type counterbalance valves - 3 way

- For closed center
- Line mounting
- Non affected by back pressure
- From SAE10 to SAE20 cavities

Technical specifications and diagrams are measured with mineral oil of 46 cSt viscosity at 40°C (104°F) temperature.

	CC10A	CC12A	CC16A	CC20A
Nominal flow	30 l/min (7.9 US gpm)	60 l/min (16 US gpm)	90 l/min (24 US gpm)	150 l/min (39.6 US gpm)
Max. pressure	350 bar (5100 psi)			
Oil leakage	80% of max. pressure setting	0.25 cm <sup>3</sup> /min (0.015 in <sup>3</sup> /min)	0.25 cm <sup>3</sup> /min (0.015 in <sup>3</sup> /min)	0.25 cm <sup>3</sup> /min (0.015 in <sup>3</sup> /min)
Fluid	mineral based oil			
Viscosity	10-200 cSt			
Max level of contamination	20/18/14 ISO4406			
Fluid temperature	with NBR seals with FPM seals	from -20°C (-4°F) to 80°C (176°F) from -20°C (-4°F) to 100°C (212°F)		
Environmental temp. for working conditions	from -20°C (-4°F) to 50°C (122°F)			
Cavity	SAE 10/3	SAE 12/3	SAE 16/3	SAE 20/3
Weight	0.280 kg (0.62 lb)	0.380 kg (0.84 lb)	0.720 kg (1.59 lb)	1.200 kg (2.64 lb)

NOTE - For different conditions, please contact Walvoil Sales Dpt.

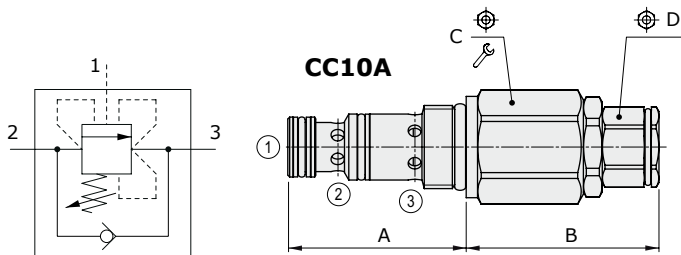

Valve type	A		B		C		D		
	mm	in	mm	in	Nm	lbft			
CC10A/	4S	47.2	1.86	51	2.01	27	50	37	19
	W	47.2	1.86	51	2.01	27	50	37	19
CC12A/	4S	73.5	2.89	60	2.36	32	80	59	24
	4W	73.5	2.89	60	2.36	32	80	59	24
CC16A/	4S	75	2.95	69	2.72	41	100	74	27
	4W	75	2.95	69	2.72	41	100	74	27
CC20A/	4S	99.5	3.92	83.5	3.29	46	100	74	36
	4W	99.5	3.92	83.5	3.29	46	100	74	36

### Ordering codes and description composition

#### CC10A/4S2B

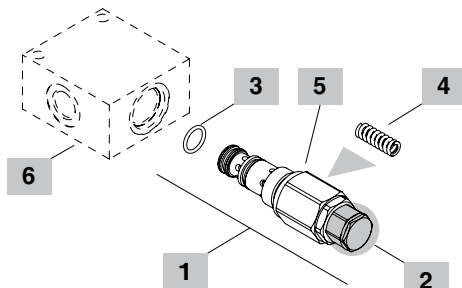
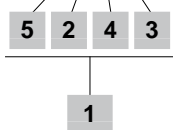

#### 1 Cartridges

TYPE	CODE	DESCRIPTION
<b>SAE cavity 10/3</b>		
CC10A/4S2B	OCC10002001	Screw type adjustment, pilo ratio 1:4 pressure range <b>2</b>
<b>SAE cavity 12/3</b>		
CC12A/4S2B	OCC12002000	Screw type adjustment, pilo ratio 1:4 pressure range <b>2</b>
<b>SAE cavity 16/3</b>		
CC16A/4S2B	OCC16002001	Screw type adjustment, pilo ratio 1:4 pressure range <b>2</b>
<b>SAE cavity 20/3</b>		
CC20A/4S0B	OCC20002001	Screw type adjustment. Setting range 20-85 bar (290-1230 psi) and standard setting 50 bar (725) at 5 l/min (1.3 US gpm)
CC20A/4S1B	OCC20002000	Screw type adjustment. Pilot ratio 1:4 Setting range 50-220 bar (725-3200 psi) and standard setting 150 bar (2170) at 5 l/min (1.3 US gpm)
CC20A/4S2B	OCC20002002	Screw type adjustment. Pilot ratio 1:4 Setting range 100-300 bar (1450-4350 psi) and std. setting 150 bar (2170) at 5 l/min (1.3 US gpm)

#### 2 Adjustments

TYPE	DESCRIPTION
<b>S</b>	Screw
<b>W</b>	Copped adjustment

#### 3 Seals

TYPE	DESCRIPTION
<b>B</b>	<b>NBR (Buna)</b> Std configuration without addition
<b>V</b>	For valve with <b>FPM (Viton)</b> o-ring seals, contact Sales Dept.

#### 4 Pressure setting springs

Standard setting is referred to 5 l/min (1.32 US gpm) flow

TYPE	CODE	DESCRIPTION
<b>For CC10A valve</b>		
<b>1</b>	3ML1092502	Setting range 50-220 bar (725-3200 psi) red band
<b>2</b>	3ML1092300	Setting range 180-350 bar (2600-5100 psi) red band
<b>3</b>	3ML1102800	Setting range 300-700 bar (4350-10150 psi) red band
<b>For CC12A valve</b>		
<b>1</b>	3ML1133201	Setting range 50-220 bar (725-3200 psi) blue band
<b>2</b>	3ML1133200	Setting range 180-350 bar (2600-5100 psi) red band
<b>3</b>	3ML1133500	Setting range 300-700 bar (4350-10150 psi) yellow band
<b>For CC16A valve</b>		
<b>1</b>	3ML1164000	Setting range 50-220 bar (725-3200 psi) blue band
<b>2</b>	3ML1164001	Setting range 180-350 bar (2600-5100 psi) red band
<b>3</b>	3ML1164002	Setting range 300-700 bar (4350-10150 psi) yellow band

#### 5 Pilot ratio

TYPE	DESCRIPTION
<b>4</b>	1:4

#### 6 Valve body

TYPE	CODE	DESCRIPTION
<b>SAE 10/3-G 3/8</b>	3CC1030C11	Aluminium body for cavity 10 valve, G3/8 std thread
<b>SAE 12/3-G 1/2</b>	3CC1230D11	Aluminium body for cavity 12 valve, G1/2 std thread
<b>SAE 16/3-G 3/4</b>	3CC1630E11	Aluminium body for cavity 16 valve, G3/4 std thread
<b>SAE 20/3-G 1</b>	3CC2030F21	Steel body for cavity 20 valve, G1 std thread

Note: aluminium body can stand up to 210 bar (3050 psi)  
For steel bodies or different threading see from page 217

**Rating diagrams**

**CC10A pressure drop vs flow**

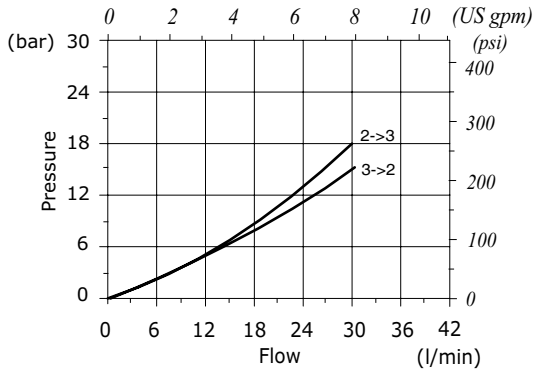

**CC12A pressure drop vs flow**

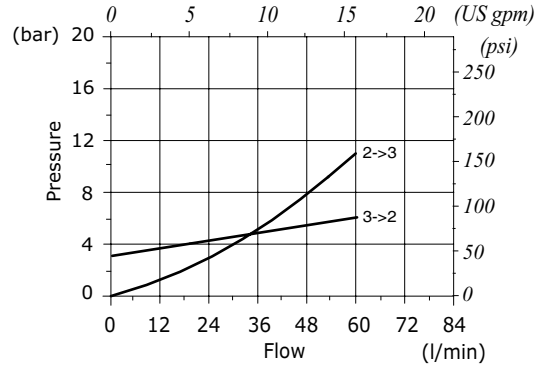

**CC16A pressure drop vs flow**

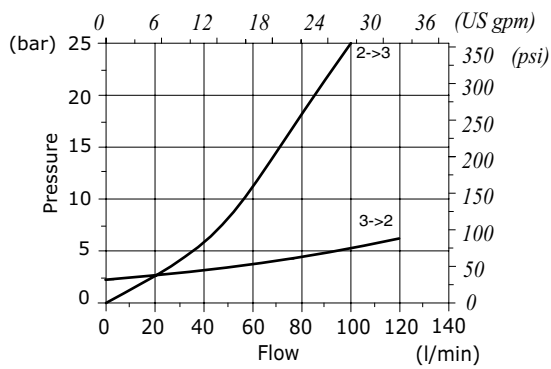

**CC20A pressure drop vs flow**

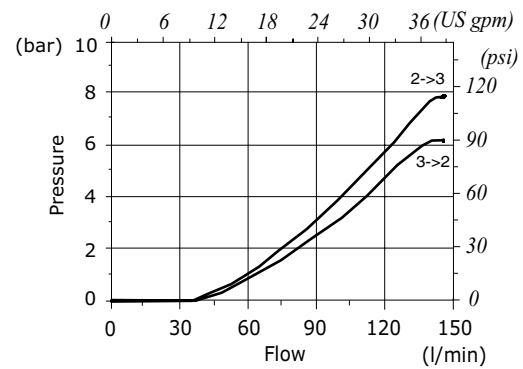





## NB..A type flow restrictor - 2 way

- Adjustable type
- From SAE08 to SAE16 cavities

Technical specifications and diagrams are measured with mineral oil of 46 cSt viscosity at 40°C (104°F) temperature.

	NB08A	NB10A	NB12A	NB16A
Nominal flow	15 l/min (3.9 US gpm)	30 l/min (7.9 US gpm)	60 l/min (16 US gpm)	100 l/min (26 US gpm)
Max. pressure	350 bar (5100 psi)			
Fluid	mineral based oil			
Viscosity	10-200 cSt			
Max level of contamination	20/18/14 ISO4406			
Fluid temperature	with NBR seals with FPM seals	from -20°C (-4°F) to 80°C (176°F) from -20°C (-4°F) to 100°C (212°F)		
Environmental temp. for working conditions	from -20°C (-4°F) to 50°C (122°F)			
Cavity	SAE 08/2	SAE 10/2	SAE 12/2	SAE 16/2
Weight	0.180 kg (0.40 lb)	0.200 kg (0.44 lb)	0.280 kg (0.62 lb)	0.500 kg (1.10 lb)

NOTE - For different conditions, please contact Walvoil Sales Dpt.

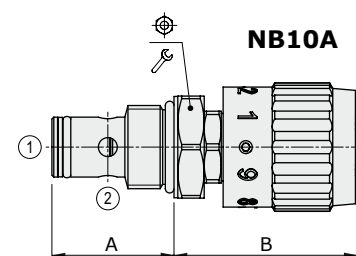
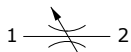

Valve type	A		B		⊕	🔧	Nm	lbft
	mm	in	mm	in				
NB08A/AM	27.6	1.09	52	2.05	24	30	22	
NB10A/AM	32.3	1.27	48	1.89	27	50	36	
NB12A/AM	46	1.81	49.2	1.94	32	80	59	
NB16A/AM	45.2	1.79	68.8	2.71	41	100	73	

For dimensions with different type of adjustment see page 212

### Ordering codes and description composition

#### NB08A/AM0B

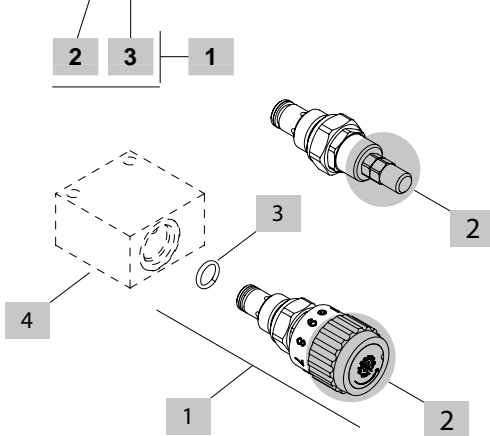

#### 2 Adjustments

TYPE	DESCRIPTION
<b>S</b>	Screw
<b>M</b>	Handknob calibrated
<b>W</b>	Copped adjustment

#### 3 Seals

TYPE	DESCRIPTION
<b>B</b>	<b>NBR (Buna)</b> Std configuration without addition
<b>V</b>	For valve with <b>FPM (Viton)</b> o-ring seals, contact Sales Dept.

#### 4 Valve body

TYPE	CODE	DESCRIPTION
<b>SAE 08/2-G 3/8</b>	3CC0820C11	Aluminium body for cavity 08 valve, G3/8 std thread
<b>SAE 10/2-G 3/8</b>	3CC1020C11	Aluminium body for cavity 10 valve, G3/8 std thread
<b>SAE 12/2-G 1/2</b>	3CC1220D11	Aluminium body for cavity 12 valve, G1/2 std thread
<b>SAE 16/2-G 3/4</b>	3CC1620E11	Aluminium body for cavity 16 valve, G3/4 std thread

Note: aluminium body can stand up to 210 bar (3050 psi)  
For steel bodies or different threading see from page 215

#### 1 Cartridges

TYPE	CODE	DESCRIPTION
<b>SAE cavity 08/2</b>		
<b>NB08A/AM0B</b>	0NB08002000	Handknob adjustment
<b>NB08A/AS0B</b>	0NB08002001	Screw type adjustment
<b>SAE cavity 10/2</b>		
<b>NB10A/AM0B</b>	0NB10002003	Handknob adjustment
<b>NB10A/AS0B</b>	0NB10002001	Screw type adjustment
<b>SAE cavity 12/2</b>		
<b>NB12A/AM0B</b>	0NB12002002	Handknob adjustment
<b>NB12A/AS0B</b>	0NB12002001	Screw type adjustment
<b>SAE cavity 16/2</b>		
<b>NB16A/AM0B</b>	0NB16002000	Handknob adjustment

### Rating diagrams

**NB08A: pressure drop vs flow 1->2 - 2->1, fully open**

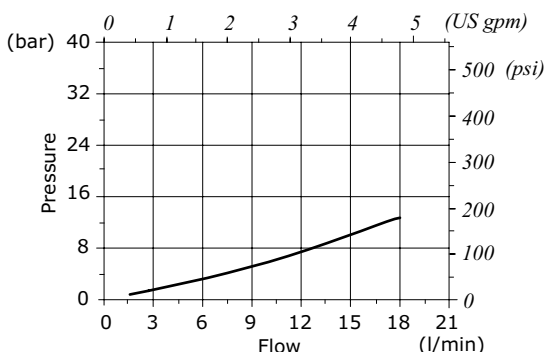

**NB10A: pressure drop vs flow 1->2 - 2->1, fully open**

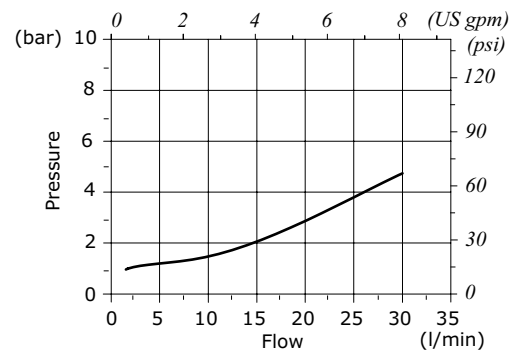

**NB12A: pressure drop vs flow 1->2 - 2->1, fully open**

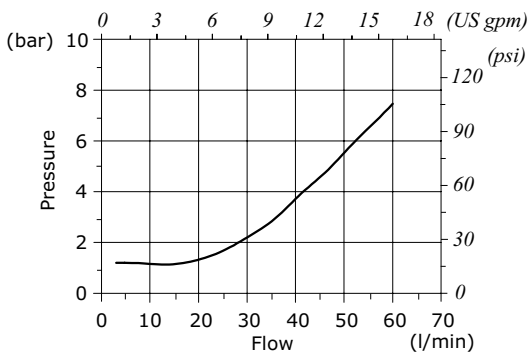

**NB16A: pressure drop vs flow 1->2 - 2->1, fully open**

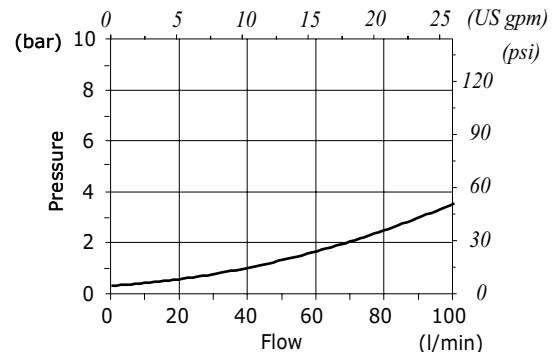





## NU..A type flow restrictor - 2 way

- Adjustable type
- Free return line
- From SAE08 to SAE16 cavities

Technical specifications and diagrams are measured with mineral oil of 46 cSt viscosity at 40°C (104°F) temperature.

	NU08A	NU10A	NU12A	NU16A
Nominal flow	15 l/min (3.9 US gpm)	30 l/min (7.9 US gpm)	60 l/min (16 US gpm)	100 l/min (26 US gpm)
Max. pressure	350 bar (5100 psi)			
Fluid	mineral based oil			
Viscosity	10-200 cSt			
Max level of contamination	20/18/14 ISO4406			
Fluid temperature	with NBR seals with FPM seals	from -20°C (-4°F) to 80°C (176°F) from -20°C (-4°F) to 100°C (212°F)		
Environmental temp. for working conditions	from -20°C (-4°F) to 50°C (122°F)			
Cavity	SAE 08/2	SAE 10/2	SAE 12/2	SAE 16/2
Weight	0.240 kg (0.53 lb)	0.290 kg (0.64 lb)	0.400 kg (0.88 lb)	0.550 kg (1.21 lb)

NOTE - For different conditions, please contact Walvoil Sales Dpt.

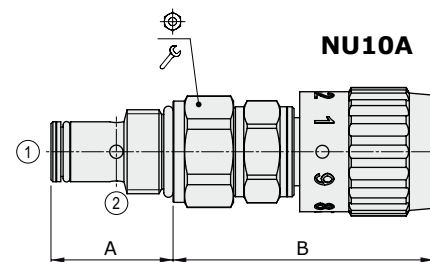
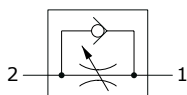

Valve type	A		B		⊕	🔑	Nm	lbf·ft
	mm	in	mm	in				
NU08A/AM	27.6	1.09	66.5	2.62	24	30	22	
NU10A/AM	32.3	1.27	68	2.68	27	50	36	
NU12A/AM	46	1.81	69	2.72	32	80	59	
NU16A/AM	45.2	1.79	66.9	2.63	41	100	73	

For dimensions with different type of adjustment see page 212

### Ordering codes and description composition

#### NU08A/AM1B

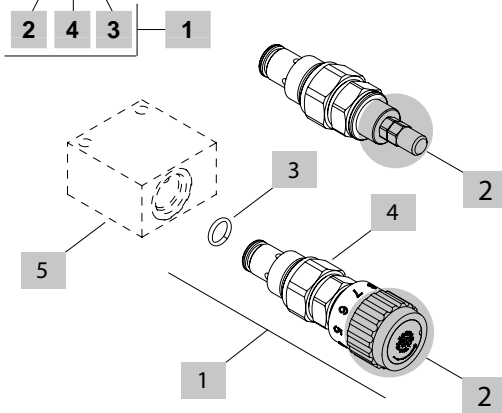

#### 1 Cartridges

TYPE	CODE	DESCRIPTION
<b>SAE cavity 08/2</b>		
NU08A/AM1B	0NU08002000	Handknob adjustment
NU08A/AS1B	0NU08002001	Screw type adjustment
<b>SAE cavity 10/2</b>		
NU10A/AM1B	0NU10002000	Handknob adjustment
NU10A/AS1B	0NU10002001	Screw type adjustment
<b>SAE cavity 12/2</b>		
NU12A/AM1B	0NU12002000	Handknob adjustment
NU12A/AS1B	0NU12002001	Screw type adjustment
<b>SAE cavity 16/2</b>		
NU16A/AM1B	0NU16002000	Handknob adjustment

#### 2 Adjustments

TYPE	DESCRIPTION
<b>S</b>	Screw
<b>M</b>	Handknob calibrated
<b>W</b>	Copped adjustment

#### 3 Seals

TYPE	DESCRIPTION
<b>B</b>	<b>NBR (Buna)</b> Std configuration without addition
<b>V</b>	For valve with <b>FPM (Viton)</b> o-ring seals, contact Sales Dept.

#### 4 Opening pressure check valve from 1 to 2

TYPE	DESCRIPTION
<b>1</b>	0.5 bar (7.3 psi)

#### 5 Valve body

TYPE	CODE	DESCRIPTION
<b>SAE 08/2-G 3/8</b>	3CC0820C11	Aluminium body for cavity 08 valve, G3/8 std thread
<b>SAE 10/2-G 3/8</b>	3CC1020C11	Aluminium body for cavity 10 valve, G3/8 std thread
<b>SAE 12/2-G 1/2</b>	3CC1220D11	Aluminium body for cavity 12 valve, G1/2 std thread
<b>SAE 16/2-G 3/4</b>	3CC1620E11	Aluminium body for cavity 16 valve, G3/4 std thread

Note: aluminium body can stand up to 210 bar (3050 psi)  
For steel bodies or different threading see from page 215

### Rating diagrams

NU08A pressure drop vs flow

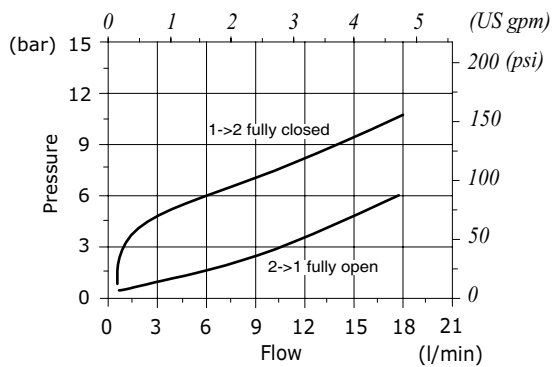

NU10A pressure drop vs flow

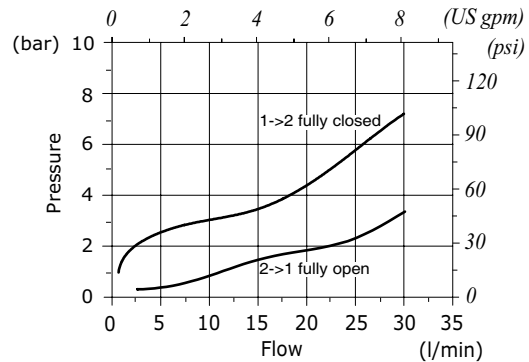

NU12A pressure drop vs flow

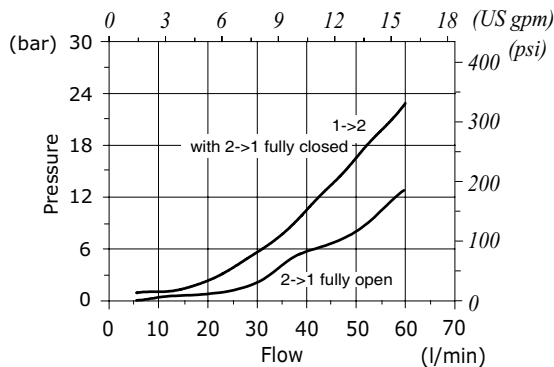

NU16A pressure drop vs flow

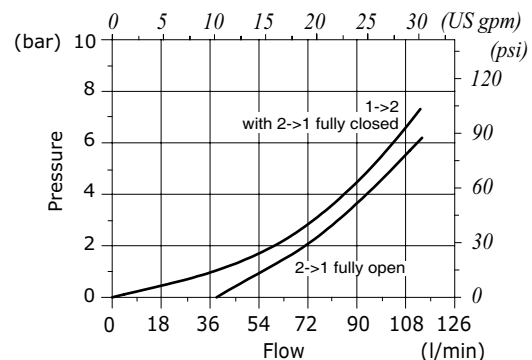



## NT..A type flow restrictor - 2 way

- Adjustable type
- With reverse free flow check
- From SAE08 to SAE16 cavities

Technical specifications and diagrams are measured with mineral oil of 46 cSt viscosity at 40°C (104°F) temperature.

	NT08A	NT10A	NT12A	NT16A
Nominal flow	15 l/min (3.9 US gpm)	30 l/min (7.9 US gpm)	60 l/min (16 US gpm)	100 l/min (26 US gpm)
Max. pressure	350 bar (5100 psi)			
Fluid	mineral based oil			
Viscosity	10-200 cSt			
Max level of contamination	20/18/14 ISO4406			
Fluid temperature	with NBR seals with FPM seals	from -20°C (-4°F) to 80°C (176°F) from -20°C (-4°F) to 100°C (212°F)		
Environmental temp. for working conditions	from -20°C (-4°F) to 50°C (122°F)			
Cavity	SAE 08/2	SAE 10/2	SAE 12/2	SAE 16/2
Weight	0.240 kg (0.53 lb)	0.290 kg (0.64 lb)	0.400 kg (0.88 lb)	0.550 kg (1.21 lb)

NOTE - For different conditions, please contact Walvoil Sales Dpt.

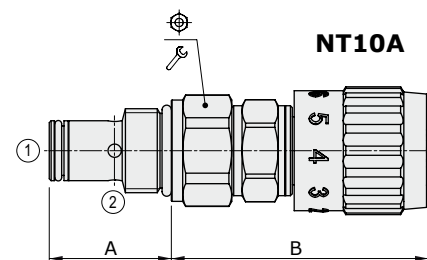
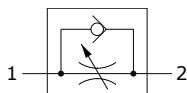

Valve type	A		B		⊕	⌘	Nm	lbf·ft
	mm	in	mm	in				
NT08A/AM	27.6	1.09	67.5	2.66	24	30	22	
NT10A/AM	32.3	1.27	68	2.68	27	50	36	
NT12A/AM	46	1.81	69	2.72	32	80	59	
NT16A/AM	45.2	1.79	68.9	2.71	41	100	74	

For dimensions with different type of adjustment see page 212

### Ordering codes and description composition

#### NT08A/AM1B

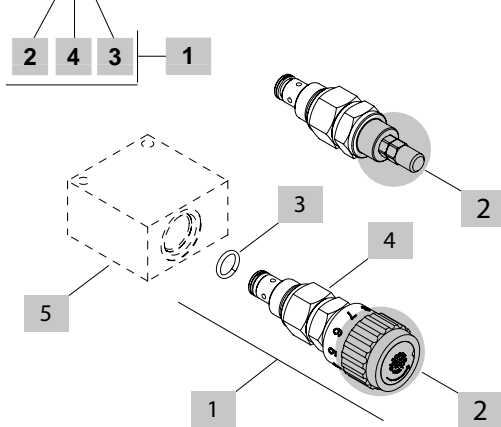

#### 1 Cartridges

TYPE	CODE	DESCRIPTION
<b>SAE cavity 08/2</b>		
NT08A/AM1B	ONT08002000	Handknob adjustment
NT08A/AS1B	ONT08002001	Screw type adjustment
<b>SAE cavity 10/2</b>		
NT10A/AM1B	ONT10002000	Handknob adjustment
NT10A/AS1B	ONT10002001	Screw type adjustment
<b>SAE cavity 12/2</b>		
NT12A/AM1B	ONT12002000	Handknob adjustment
NT12A/AS1B	ONT12002001	Screw type adjustment
<b>SAE cavity 16/2</b>		
NT16A/AM1B	ONT16002000	Handknob adjustment

#### 2 Adjustments

TYPE	DESCRIPTION
<b>S</b>	Screw
<b>M</b>	Handknob calibrated
<b>W</b>	Copped adjustment

#### 3 Seals

TYPE	DESCRIPTION
<b>B</b>	<b>NBR (Buna)</b> Std configuration without addition
<b>V</b>	For valve with <b>FPM (Viton)</b> o-ring seals, contact Sales Dept.

#### 4 Opening pressure check valve from 1 to 2

TYPE	DESCRIPTION
<b>1</b>	0.5 bar (7.3 psi)

#### 5 Valve body

TYPE	CODE	DESCRIPTION
<b>SAE 08/2-G 3/8</b>	3CC0820C11	Aluminium body for cavity 08 valve, G3/8 std thread
<b>SAE 10/2-G 3/8</b>	3CC1020C11	Aluminium body for cavity 10 valve, G3/8 std thread
<b>SAE 12/2-G 1/2</b>	3CC1220D11	Aluminium body for cavity 12 valve, G1/2 std thread
<b>SAE 16/2-G 3/4</b>	3CC1620E11	Aluminium body for cavity 16 valve, G3/4 std thread

Note: aluminium body can stand up to 210 bar (3050 psi)  
For steel bodies or different threading see from page 215

### Rating diagrams

NT08A pressure drop vs flow

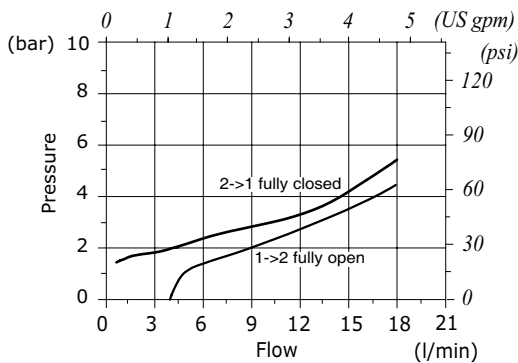

NT10A pressure drop vs flow

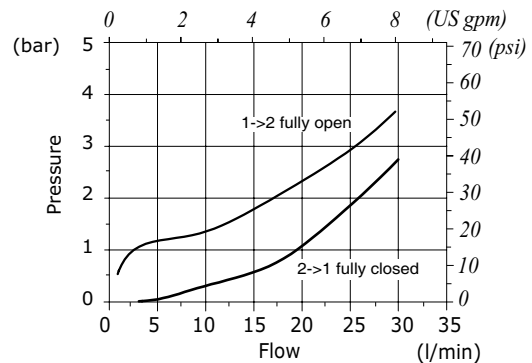

NT12A pressure drop vs flow

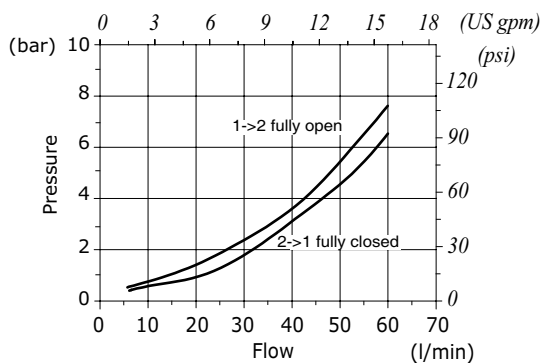

NT16A pressure drop vs flow

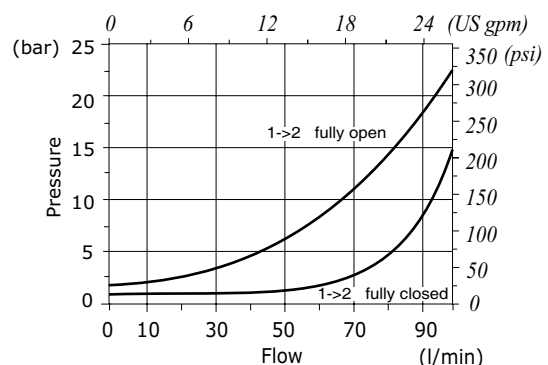



## EE..X type flow restrictor - 2 way

- Solenoid proportional type
- To be combined with an external compensator
- SAE10 and SAE12 cavities

Technical specifications and diagrams are measured with mineral oil of 46 cSt viscosity at 40°C (104°F) temperature.

	EE10X	EE12X	
Nominal flow <sup>(1)</sup>	with 10 bar (145 psi) stand-by	40 l/min (10.6 US gpm)	60 l/min (15.8 US gpm)
Max. pressure		315 bar (4600 psi)	315 bar (4600 psi)
Oil leakage	at 150 bar (2175 psi)	150 cm <sup>3</sup> /min (9.1 in <sup>3</sup> /min)	200 cm <sup>3</sup> /min (9.1 in <sup>3</sup> /min)
Fluid		mineral based oil	
Viscosity		12-200 cSt	
Max level of contamination		18/16/13 ISO4406	
Fluid temperature	with NBR seals with FPM seals	from -20°C (-4°F) to 80°C (176°F)	from -20°C (-4°F) to 100°C (212°F)
Environmental temp. for working conditions		from -20°C (-4°F) to 50°C (122°F)	
Cavity		SAE 10/2	SAE 12/2
Coil type <sup>(2)</sup>		BQP19 or BH	
Nominal voltages		12 VDC - 24 VDC ± 10%	
Power rating		22,8 W (12 VDC)	22,5 W (24 VDC)
Max control current		12 V -> 1.25 A - 24 V -> 0.63 A (BQP19)	12 V -> 1.70 A - 24 V -> 0.85 A (BH)
Dither frequency		150 Hz	
Weight		0.3 kg (0.66 lb) kg	

NOTE - For different conditions, please contact Walvoil Sales Dpt. - <sup>(1)</sup> Values are checked with cartridge in parallel with compensator - <sup>(2)</sup> For coils further features see from page 206.

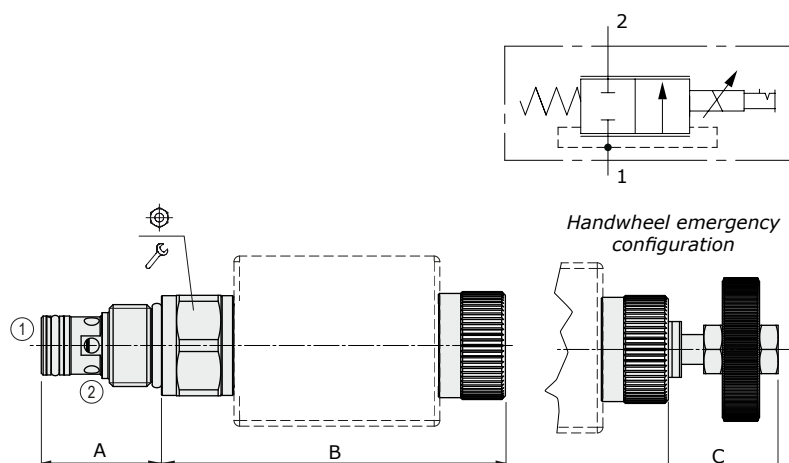

Valve type	A		B		C				Nm	lbft
	mm	in	mm	in	mm	in				
EE10X	32.3	1.27	92.4	3.64	29.5	1.16	27	50	37	
EE12X	45	1.77	94.9	3.74	29.5	1.16	32	80	59	

For dimensions with different type of emergency see page 213

### Ordering codes and description composition

#### EE10X/22NB

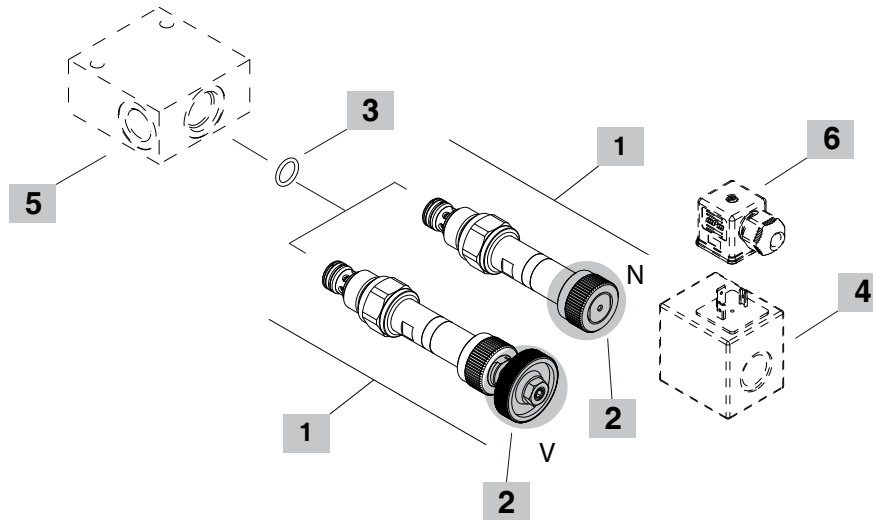
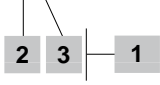

#### 1 Cartridges

TYPE	CODE	DESCRIPTION
<b>SAE cavity 10/2</b>		
<b>EE10X/22NB</b>	0EE10002009	Without emergency
<b>EE10X/22VB</b>	0EE10002008	Handwheel emergency
<b>SAE cavity 12/2</b>		
<b>EE12X/20NB</b>	0EE12002007	Without emergency
<b>EE12X/20VB</b>	0EE12002009	Handwheel emergency

#### 2 Emergency

TYPE	DESCRIPTION
<b>N</b>	Without emergency
<b>V</b>	Handknob emergency

#### 3 Seals

TYPE	DESCRIPTION
<b>B</b>	<b>NBR (Buna)</b> Std configuration without addition
<b>V</b>	For valve with <b>FPM (Viton)</b> o-ring seals, contact Sales Dept.

#### 4 Coils

TYPE	CODE	DESCRIPTION
<b>BQP19 12VDC</b>	4SL5000126	Coil 12VDC-ISO4400

For complete coils list see from page 206  
It is possible also combine coils BH

#### 5 Valve body

TYPE	CODE	DESCRIPTION
<b>SAE 10/2-G 3/8</b>	3CC1020C11	Aluminium body for cavity 10 valve, G3/8 std thread
<b>SAE 12/2-G 1/2</b>	3CC1220D11	Aluminium body for cavity 12 valve, G1/2 std thread

Note: aluminium body can stand up to 210 bar (3050 psi)  
For steel bodies or different threading see from page 215

#### 6 Connector

TYPE	CODE	DESCRIPTION
<b>ISO4400</b>	4CN1009995	Connector

For complete connectors list see from page 206

**Rating diagrams**

**EE10X**  
flow regulating vs. % max. control current

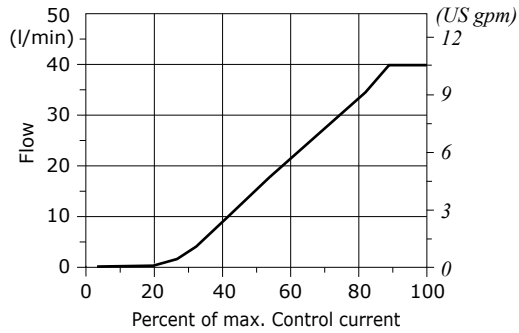

**EE10X**  
\*pressure compensation diagram 1→2

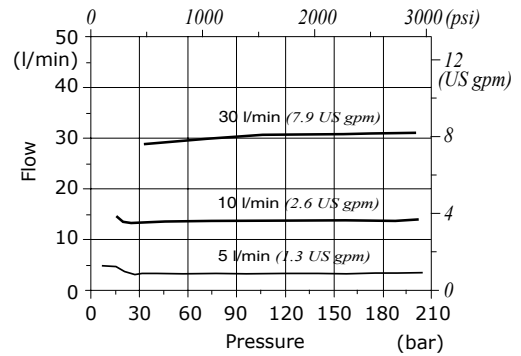

**EE12X**  
flow regulating vs. % max. control current

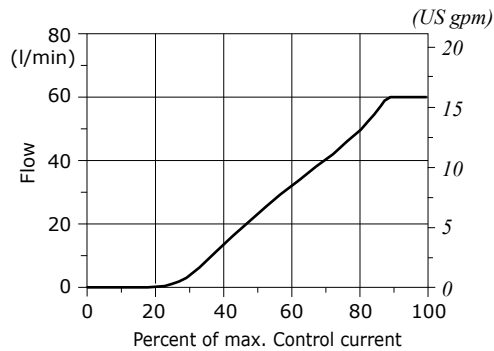

**EE12X**  
\*\*pressure compensation diagram 1→2

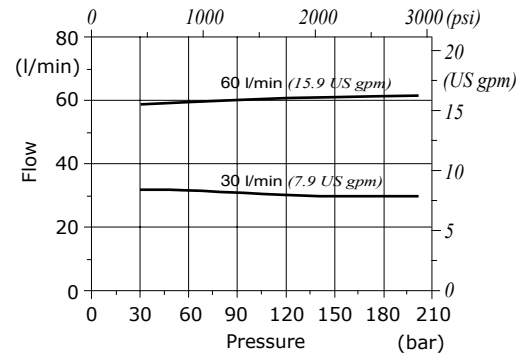

\*Compensation diagram were detected with the cartridge combined with a VPR/3/ET 38-12 compensator with 10 bar (145 psi) stand by  
\*\*Compensation diagram were detected with the cartridge combined with a VPR/3/ET 38-12 compensator with 7 bar (102 psi) stand by







## EC..T type flow restrictor - 2 way

- Solenoid proportional type
- To be combined with an external compensator
- From SAE08 to SAE16 cavities

Technical specifications and diagrams are measured with mineral oil of 46 cSt viscosity at 40°C (104°F) temperature.

		EC08T	EC10T	EC12T	EC16T
Nominal flow <sup>(1)</sup>	with 5 bar (72.5 psi) stand-by	35 l/min (9.2 US gpm)	44 l/min (11.6 US gpm)	55 l/min (15.5 US gpm)	70 l/min (18.5 US gpm)
	with 10 bar (145 psi) stand-by	44 l/min (11.6 US gpm)	58 l/min (15.3 US gpm)	70 l/min (18.5 US gpm)	97 l/min (25.6 US gpm)
Max. pressure		350 bar (5100 psi)			
Oil leakage	at 350 bar (5100 psi)	0.25 cm <sup>3</sup> /min (0.015 in <sup>3</sup> /min)	0.25 cm <sup>3</sup> /min (0.015 in <sup>3</sup> /min)	0.25 cm <sup>3</sup> /min (0.015 in <sup>3</sup> /min)	0.35 cm <sup>3</sup> /min (0.021 in <sup>3</sup> /min)
Fluid		mineral based oil			
Viscosity		12-200 cSt			
Max level of contamination		18/16/13 ISO4406			
Fluid temperature	with NBR seals with FPM seals	from -20°C (-4°F) to 80°C (176°F) from -20°C (-4°F) to 100°C (212°F)			
Environmental temp. for working conditions		from -20°C (-4°F) to 50°C (122°F)			
Cavity		SAE 08/2	SAE 10/2	SAE 12/2	SAE 16/2
Coil type <sup>(2)</sup>		BH			
Nominal voltages		12 VDC - 24 VDC ± 10%			
Power rating		22.8 W (12 VDC) 22.5 W (24 VDC)			
Max control current		12 V -> 1.70 A - 24 V -> 0.85 A (BH)			
Dither frequency		from 100 Hz to 120 Hz			
Weight		0.275 kg (0.61 lb)	0.310 kg (0.68 lb)	0.390 kg (0.86 lb)	0.490 kg (1.08 lb)

NOTE - For different conditions, please contact Walvoil Sales Dpt. - <sup>(1)</sup> Values are checked with cartridge in parallel with compensator  
<sup>(2)</sup> For coils further features see from page 206.

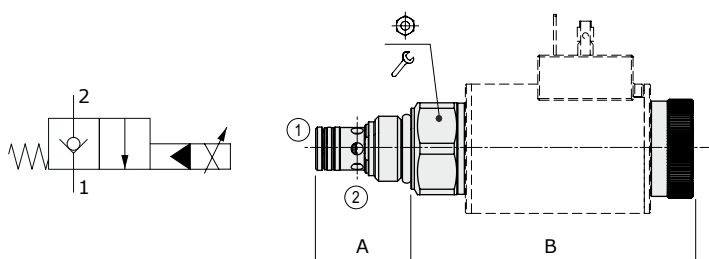

Valve type	A		B		⌀	Nm	lbf <sup>ft</sup>
	mm	in	mm	in			
EC08T	28.1	1.11	83	3.27	27	50	37
EC10T	32.5	1.28	83	3.27	27	50	37
EC12T	45	1.77	82.5	3.25	32	85	63
EC16T	45.6	1.80	81	3.19	32	85	63

For dimensions with different type of emergency see page 213

### Ordering codes and description composition

#### EC10T/A0NB

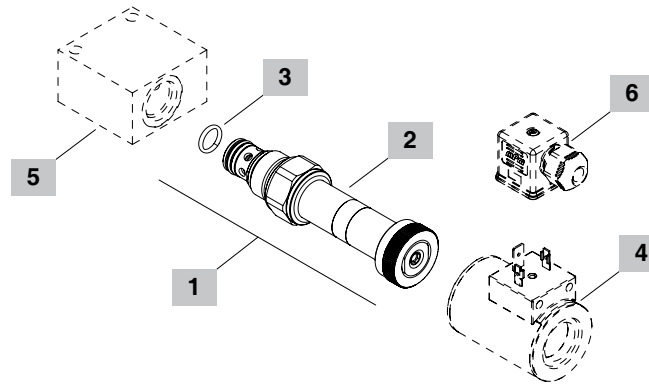
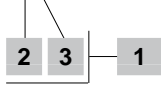

#### 1 Cartucce

TYPE	CODE	DESCRIPTION
<b>SAE cavity 08/2</b>		
EC08T/A0NB	0EC08002056	Without emergency
EC08T/A0TB	0EC08002058	Screw type emergency
EC08T/A0QB	0EC08002073	"Push&twist" emergency
<b>SAE cavity 10/2</b>		
EC10T/A0NB	0EC10002025	Without emergency
EC10T/A0TB	0EC10002027	Screw type emergency
EC10T/A0QB	0EC10002029	"Push&twist" emergency
<b>SAE cavity 12/2</b>		
EC12T/A0NB	0EC12002018	Without emergency
EC12T/A0TB	0EC12002019	Screw type emergency
EC12T/A0QB	0EC12002020	"Push&twist" emergency
<b>SAE cavity 16/2</b>		
EC16T/A0NB	0EC16002033	Without emergency
EC16T/A0TB	0EC16002035	Screw type emergency
EC16T/A0QB	0EC16002038	"Push&twist" emergency

#### 2 Emergenze

TYPE	DESCRIPTION
N	Without emergency
T	Screw type emergency
Q	"Push&twist" emergency

#### 3 Seals

TYPE	DESCRIPTION
B	<b>NBR (Buna)</b> Std configuration without addition
V	For valve with <b>FPM (Viton)</b> o-ring seals, contact Sales Dept.

#### 4 Bobine

TYPE	CODE	DESCRIPTION
BH 12VDC	4SLD001200	Coil 12VDC-ISO4400

For complete coils list see from page 206  
It is possible also combine coils BQP19

#### 5 Valve body

TYPE	CODE	DESCRIPTION
SAE 08/2-G 3/8	3CC0820C11	Aluminium body for cavity 08 valve, G3/8 std thread
SAE 10/2-G 3/8	3CC1020C11	Aluminium body for cavity 10 valve, G3/8 std thread
SAE 12/2-G 1/2	3CC1220D11	Aluminium body for cavity 12 valve, G1/2 std thread
SAE 16/2-G 3/4	3CC1620E11	Aluminium body for cavity 16 valve, G3/4 std thread

Note: aluminium body can stand up to 210 bar (3050 psi)  
For steel bodies or different threading see from page 215

#### 6 Connector

TYPE	CODE	DESCRIPTION
ISO4400	4CN1009995	Connector

For complete connectors list see from page 206

**EC08T  
pressure drop**

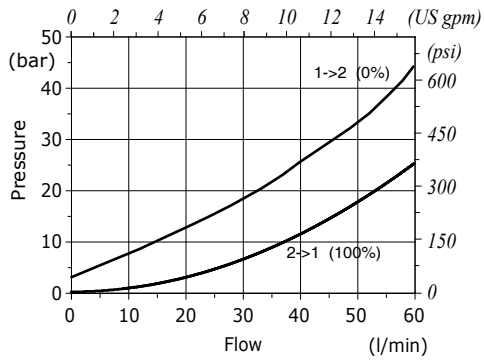

**EC08T  
pressure drop**

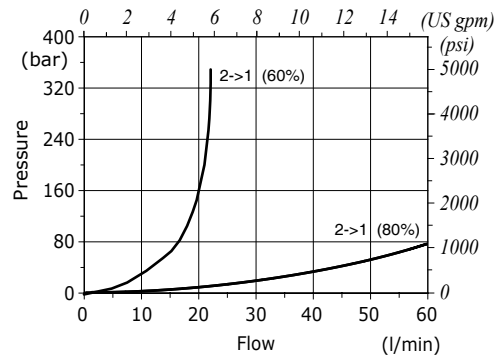

**EC08T  
flow regulating vs. % max. control current**

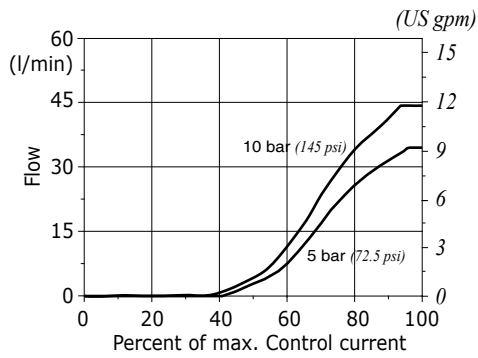

**EC10T  
pressure drop**

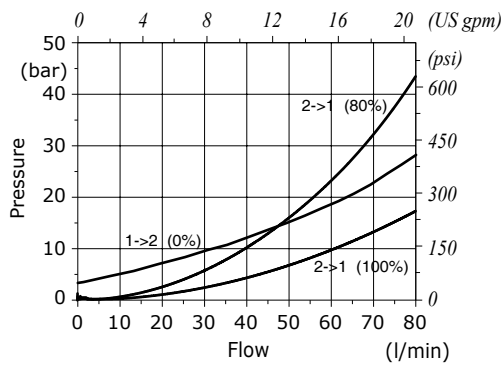

**EC10T  
pressure drop**

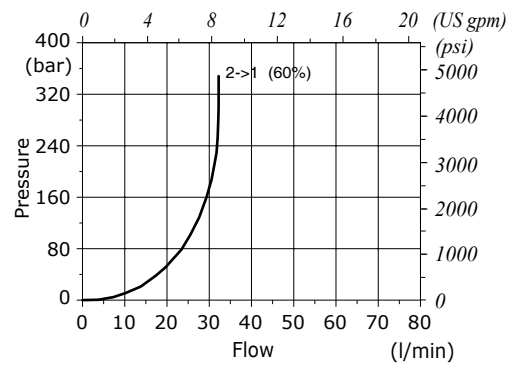

**EC10T  
flow regulating vs. % max. control current**

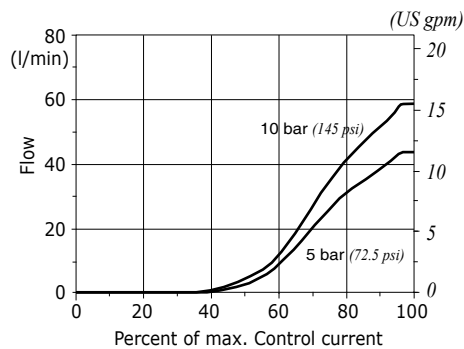

Rating diagrams

**EC12T  
pressure drop**

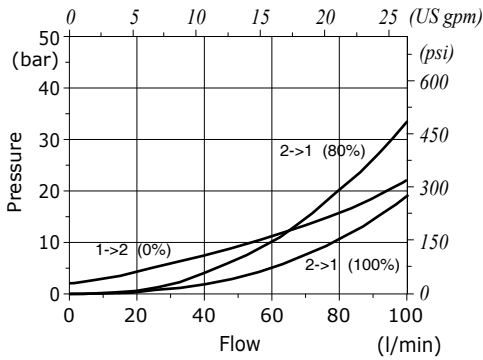

**EC12T  
pressure drop**

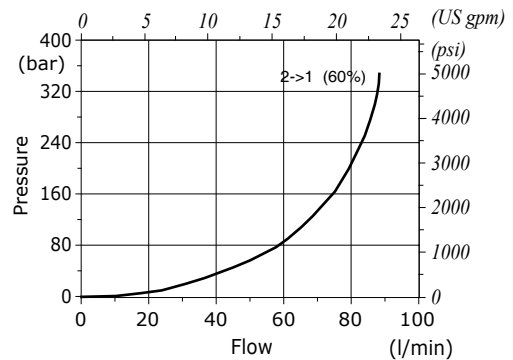

**EC12T  
flow regulating vs. % max. control current**

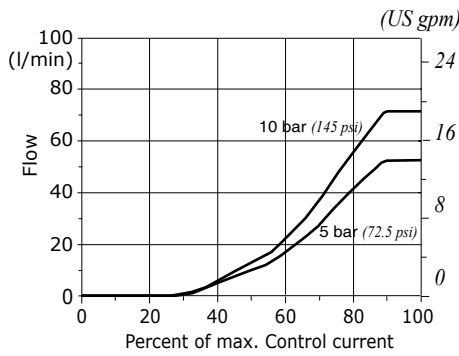

**EC16T  
pressure drop**

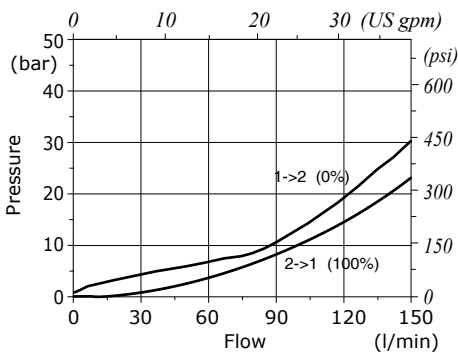

**EC6T  
pressure drop**

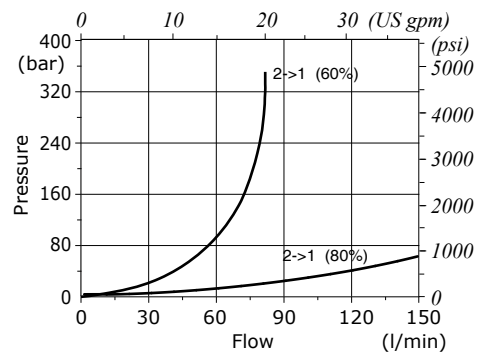

**EC16T  
flow regulating vs. % max. control current**

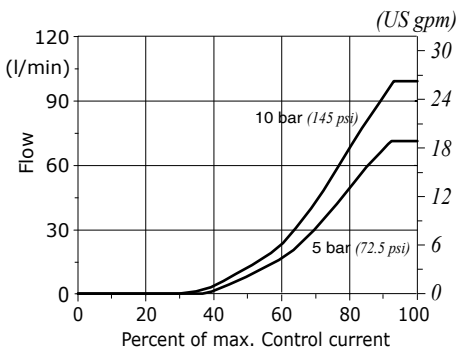



## PW..A type flow control pressure compensated valves - 2 way

- With reverse free flow check
- From SAE08 to SAE16 cavities

Technical specifications and diagrams are measured with mineral oil of 46 cSt viscosity at 40°C (104°F) temperature.

	<b>PW08A</b>	<b>PW10A</b>	<b>PW12A</b>	<b>PW16A</b>
Nominal flow	10 l/min (2.6 US gpm)	30 l/min (7.9 US gpm)	50 l/min (13 US gpm)	90 l/min (24 US gpm)
Max. pressure	350 bar (5100 psi)			
Fluid	mineral based oil			
Viscosity	10-200 cSt			
Max level of contamination	20/18/14 ISO4406			
Fluid temperature	with NBR seals with FPM seals	from -20°C (-4°F) to 80°C (176°F) from -20°C (-4°F) to 100°C (212°F)		
Environmental temp. for working conditions	from -20°C (-4°F) to 50°C (122°F)			
Cavity	SAE 08/2 A	SAE 10/2 A	SAE 12/2 A	SAE 16/2 A
Weight	0.22 kg (0.48 lb)	0.30 kg (2.20 lb)	0.72 kg (1.58 lb)	0.98 kg (2.16 lb)

NOTE - For different conditions, please contact Walvoil Sales Dpt.

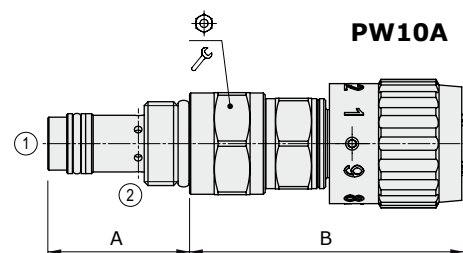
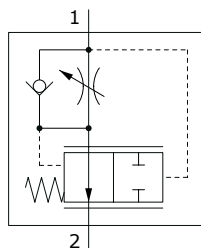

Valve type	A		B		⊕	🔧	Nm	lbft
	mm	in	mm	in				
<b>PW08A/AM</b>	36.6	1.44	64.5	2.54	24	30	22	
<b>PW10A/AM</b>	37.5	1.48	71.9	2.83	27	50	36	
<b>PW12A/AM</b>	58.5	2.30	64.5	2.54	32	80	59	
<b>PW16A/AM</b>	68	2.68	86	3.39	41	100	74	

For dimensions with different type of adjustment see page 212

Ordering codes and description composition

PW08A/AM1B

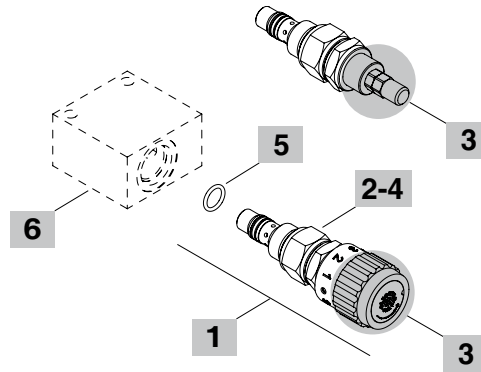
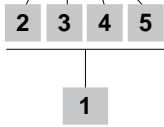

1 Cartridges			4 Pressure drop from 2 to 1		
TYPE	CODE	DESCRIPTION	TYPE	DESCRIPTION	
<b>SAE cavity 08/2 A</b>			1	0.5 bar (7.3 psi)	
PW08A/AM1B	0PW08002000	Handknob adjustment			
PW08A/AS1B	0PW08002003	Screw type adjustment			
<b>SAE cavity 10/2 A</b>					
PW10A/AM1B	0PW10002000	Handknob adjustment			
PW10A/AS1B	0PW10002001	Screw type adjustment			
<b>SAE cavity 12/2 A</b>					
PW12A/AM1B	0PW12002000	Handknob adjustment			
PW12A/AS1B	0PW12002001	Screw type adjustment			
<b>SAE cavity 16/2 A</b>					
PW16A/AM1B	0PW16002000	Handknob adjustment			
PW16A/AS1B	0PW16002001	Screw type adjustment			
2 Pressure drop from 1 to 2			5 Seals		
TYPE	DESCRIPTION		TYPE	DESCRIPTION	
A	12 bar (170 psi)		B	<b>NBR (Buna)</b> Std configuration without addition	
			V	For valve with <b>FPM (Viton)</b> o-ring seals, contact Sales Dept.	
3 Adjustments			6 Valve body		
TYPE	DESCRIPTION		TYPE	CODE	DESCRIPTION
S	Screw		<b>SAE 08/2-G 3/8</b>	3CC0820C11	Aluminium body for cavity 08 valve, G3/8 std thread
M	Handknob		<b>SAE 10/2-G 3/8</b>	3CC1020C11	Aluminium body for cavity 10 valve, G3/8 std thread
			<b>SAE 12/2-G 1/2</b>	3CC1220D11	Aluminium body for cavity 12 valve, G1/2 std thread
			<b>SAE 16/2-G 3/4</b>	3CC1620E11	Aluminium body for cavity 16 valve, G3/4 std thread
			Note: aluminium body can stand up to 210 bar (3050 psi) For steel bodies or different threading see from page 215		

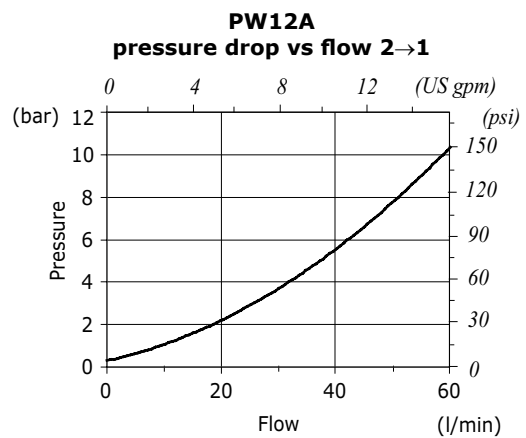
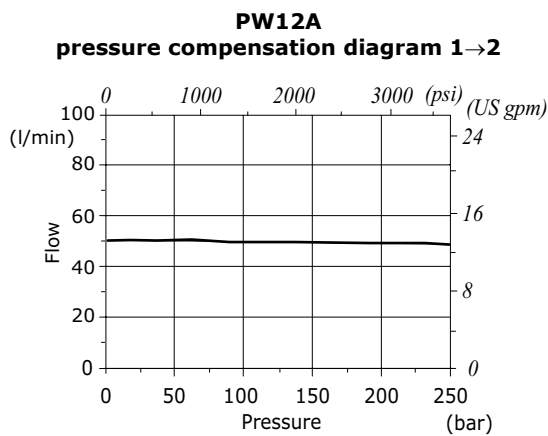
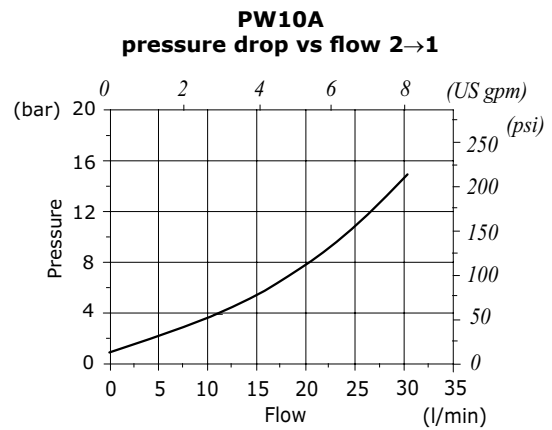
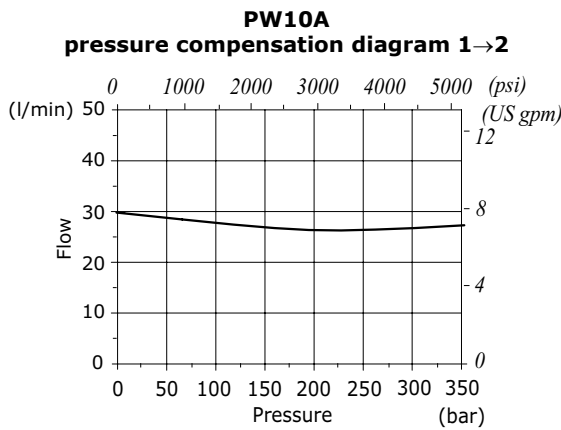
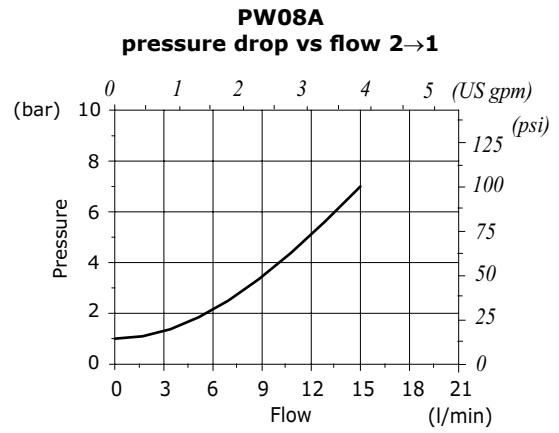
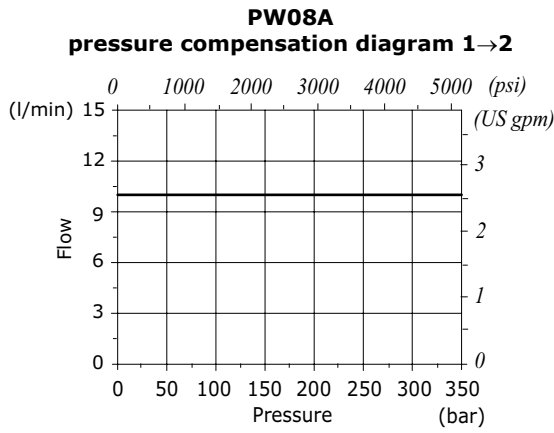

Rating diagrams

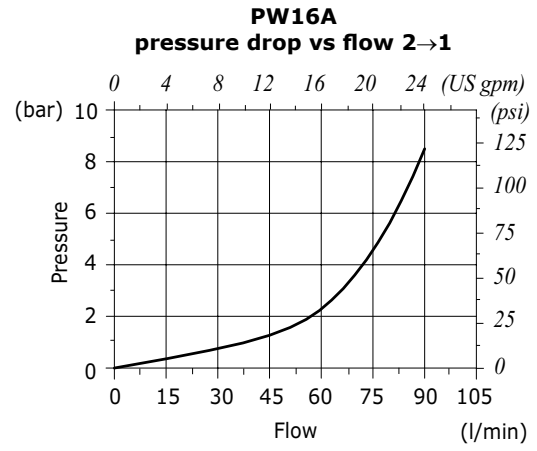
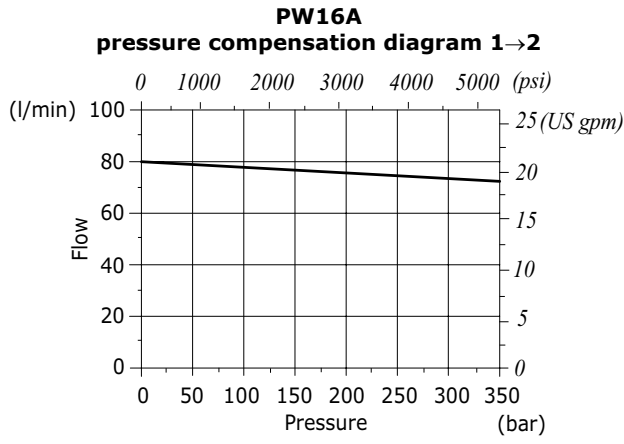





## PU..A type flow control pressure compensated valves - 2 way

- Line mounting
- From SAE08 to SAE16 cavities

Technical specifications and diagrams are measured with mineral oil of 46 cSt viscosity at 40°C (104°F) temperature.

	PU08A	PU10A	PU12A	PU16A
Nominal flow	15 l/min (3.9 US gpm)	30 l/min (7.9 US gpm)	50 l/min (13 US gpm)	90 l/min (24 US gpm)
Max. pressure	350 bar (5100 psi)			
Fluid	mineral based oil			
Viscosity	10-200 cSt			
Max level of contamination	20/18/14 ISO4406			
Fluid temperature	with NBR seals with FPM seals	from -20°C (-4°F) to 80°C (176°F) from -20°C (-4°F) to 100°C (212°F)		
Environmental temp. for working conditions	from -20°C (-4°F) to 50°C (122°F)			
Cavity	SAE 08/2 A	SAE 10/2 A	SAE 12/2 A	SAE 16/2 A
Weight	0.18 kg (0.40 lb)	0.20 kg (0.44 lb)	0.30 kg (0.66 lb)	0.55 kg (1.21 lb)

NOTE - For different conditions, please contact Walvoil Sales Dpt.

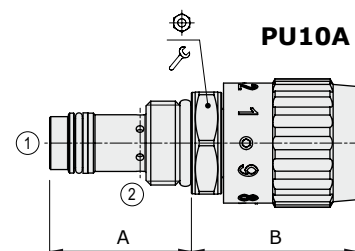
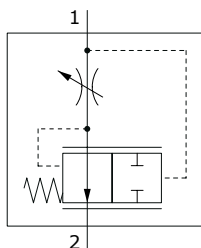

Valve type	A		B		⊕	🔧	Nm	lbft
	mm	in	mm	in				
PU08A/AM	33.6	1.32	48.5	1.91	24	30	22	
PU10A/AM	37.5	1.48	43	1.69	27	50	36	
PU12A/AM	58.5	2.30	44	1.73	32	80	59	
PU16A/AM	68	2.68	52	2.05	41	100	74	

For dimensions with different type of adjustment see page 212

**Ordering codes and description composition**

**PU08A/AM0B**

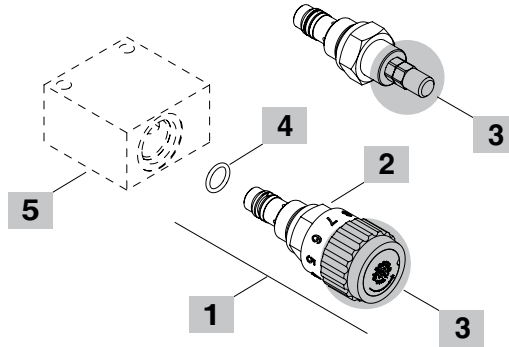
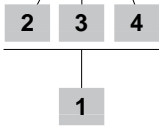

1 Cartridges			4 Seals		
TYPE	CODE	DESCRIPTION	TYPE	DESCRIPTION	
<b>SAE cavity 08/2 A</b>			<b>B</b>	<b>NBR (Buna)</b> Std configuration without addition	
<b>PU08A/AM0B</b>	0PU08002000	Handknob adjustment	<b>V</b>	For valve with <b>FPM (Viton)</b> o-ring seals, contact Sales Dept.	
<b>PU08A/AS0B</b>	0PU08002003	Screw type adjustment			
<b>SAE cavity 10/2 A</b>			<b>5 Valve body</b>		
<b>PU10A/AM0B</b>	0PU10002001	Handknob adjustment	TYPE	CODE	DESCRIPTION
<b>PU10A/AS0B</b>	0PU10002000	Screw type adjustment	<b>SAE 08/2-G 3/8</b>	3CC0820C11	Aluminium body for cavity 08 valve, G3/8 std thread
<b>SAE cavity 12/2 A</b>			<b>SAE 10/2-G 3/8</b>	3CC1020C11	Aluminium body for cavity 10 valve, G3/8 std thread
<b>PU12A/AM0B</b>	0PU12002000	Handknob adjustment	<b>SAE 12/2-G 1/2</b>	3CC1220D11	Aluminium body for cavity 12 valve, G1/2 std thread
<b>PU12A/AS0B</b>	0PU12002003	Screw type adjustment	<b>SAE 16/2-G 3/4</b>	3CC1620E11	Aluminium body for cavity 16 valve, G3/4 std thread
<b>SAE cavity 16/2 A</b>			Note: aluminium body can stand up to 210 bar (3050 psi) For steel bodies or different threading see from page 215		
<b>PU16A/AM0B</b>	0PU16002000	Handknob adjustment			
<b>PU16A/AS0B</b>	0PU16002007	Screw type adjustment			
2 Pressure drop from 1 to 2					
TYPE	DESCRIPTION				
<b>A</b>	12 bar (170 psi)				
3 Adjustments					
TYPE	DESCRIPTION				
<b>S</b>	Screw				
<b>M</b>	Handknob				

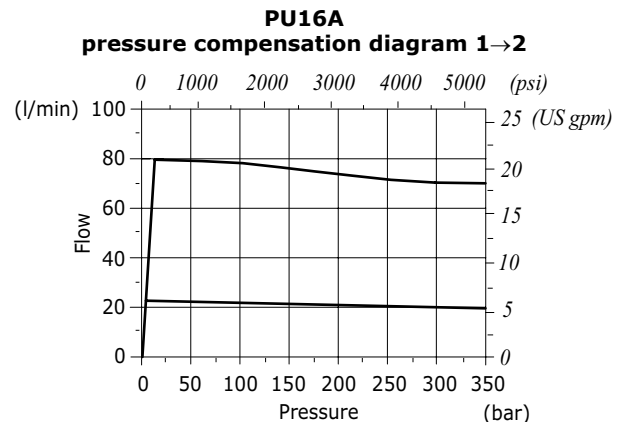
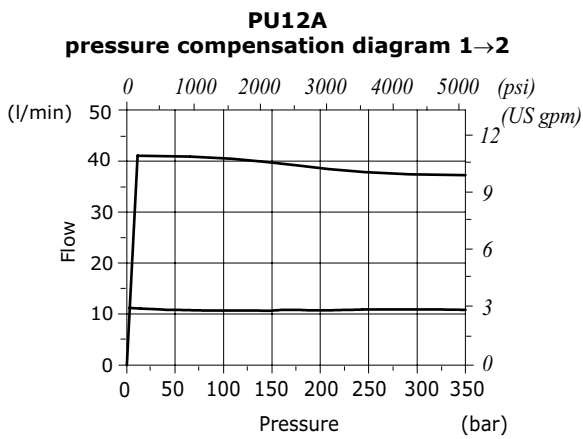
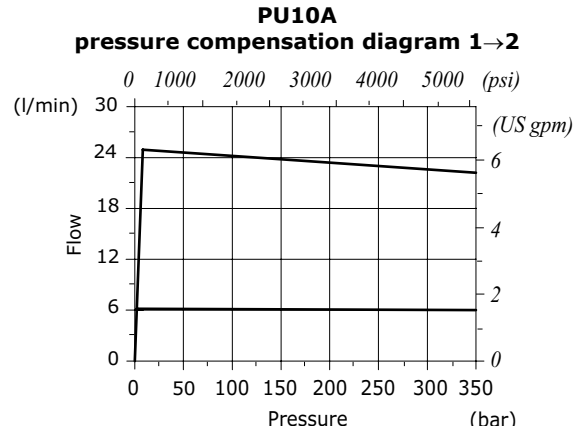
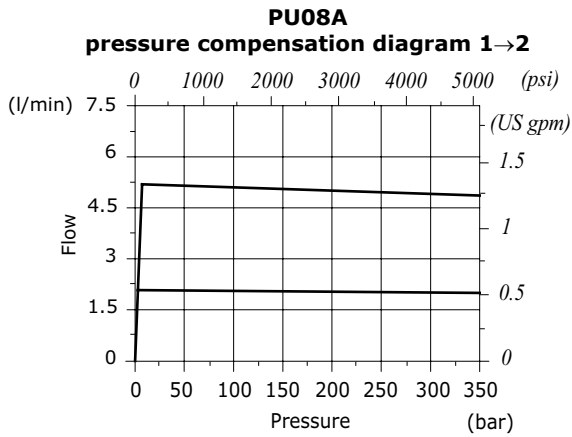





## PU..X type flow control pressure compensated valves - 2 way

- Solenoid proportional type
- From SAE08 to SAE16 cavities

Technical specifications and diagrams are measured with mineral oil of 46 cSt viscosity at 40°C (104°F) temperature.

		PU08X	PU10X	PU12X	PU16X
Nominal flow		10 l/min (2.6 US gpm)	30 l/min (7.9 US gpm)	50 l/min (13.2 US gpm)	90 l/min (23.8 US gpm)
Max. pressure		315 bar (4600 psi)			
Oil leakage	at 210 bar 3050 psi	80 cm <sup>3</sup> /min (8.9 in <sup>3</sup> /min)	150 cm <sup>3</sup> /min (9.2 in <sup>3</sup> /min)	250 cm <sup>3</sup> /min (15.3 in <sup>3</sup> /min)	400 cm <sup>3</sup> /min (24.4 in <sup>3</sup> /min)
Fluid		mineral based oil			
Viscosity		10-200 cSt			
Max level of contamination		18/16/13 ISO4406			
Fluid temperature	with NBR seals with FPM seals	from -20°C (-4°F) to 80°C (176°F) from -20°C (-4°F) to 100°C (212°F)			
Environmental temp. for working conditions		from -20°C (-4°F) to 50°C (122°F)			
Cavity		SAE 08/2 A	SAE 10/2 A	SAE 12/2 A	SAE 16/2 A
Coil type*		BH or BQP19			
Nominal voltages		12 VDC - 24V DC ± 10%			
Power rating		20.4 W (BH) - 15 W (BQP19)			
Max control current		12 V -> 1.70 A - 24 V -> 0.85 A (BH) 12 V -> 1.25 A - 24 V -> 0.63 A (BQP19)			
Dither frequency		150 Hz			
Hysteresis		8%			
Weight		0.34 kg (0.75 lb)	0.39 kg (0.86 lb)	0.51 kg (1.12 lb)	0.90 kg (1.98 lb)

NOTE - For different conditions, please contact Walvoil Sales Dpt. - For coils further features see from page 206.

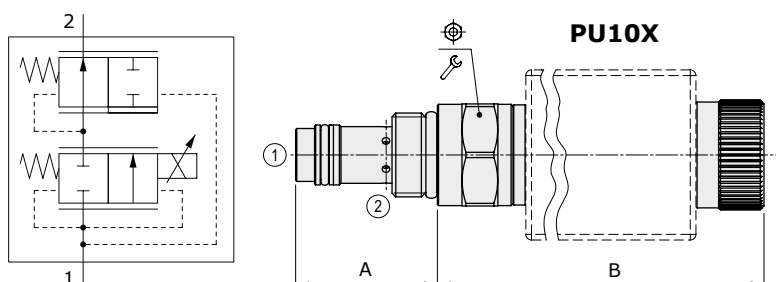

Valve type	A		B		⌀	⌀	Nm	lbf·ft
	mm	in	mm	in				
PU08X/A0N	36.6	1.44	94	3.70	24	30	22	
PU10X/A0N	37.5	1.48	96.4	3.79	27	50	37	
PU12X/A0N	58.5	2.30	97.4	3.83	32	75	55	
PU16X/A0N	68	2.68	121.4	4.78	41	95	70	

For dimensions with different type of emergency see page 213

**Ordering codes and description composition**

**PU08X/A0NB**

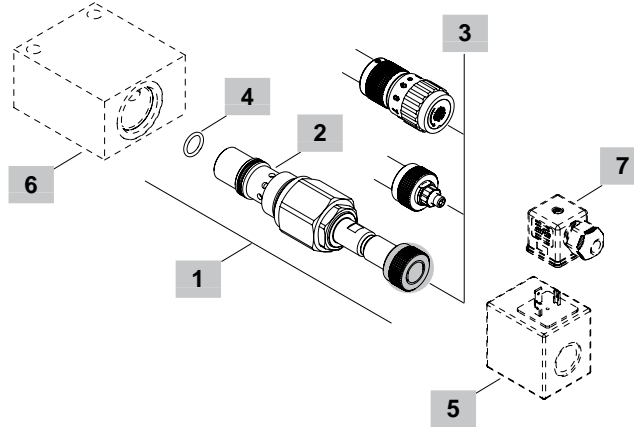
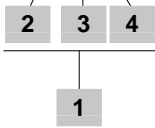

**1 Cartridges**

TYPE	CODE	DESCRIPTION
<b>SAE cavity 08/2 A</b>		
PU08X/A0NB	0PU08002012	Without emergency
PU08X/A0TB	0PU08002013	Screw type emergency
PU08X/A0VB	0PU08002014	Handknob emergency
<b>SAE cavity 10/2 A</b>		
PU10X/A0NB	0PU10002020	Without emergency
PU10X/A0TB	0PU10002021	Screw type emergency
PU10X/A0VB	0PU10002022	Handknob emergency
<b>SAE cavity 12/2 A</b>		
PU12X/A0NB	0PU12002007	Without emergency
PU12X/A0TB	0PU12002008	Screw type emergency
PU12X/A0VB	0PU12002009	Handknob emergency
<b>SAE cavity 16/2 A</b>		
PU16X/A0NB	0PU16002010	Without emergency
PU16X/A0TB	0PU16002011	Screw type emergency
PU16X/A0VB	0PU16002012	Handknob emergency

**2 Pressure drop from 1 to 2**

TYPE	DESCRIPTION
A	12 bar (170 psi)

**3 Emergency**

TYPE	DESCRIPTION
N	Without emergency
T	Screw type
V	Handknob

**4 Seals**

TYPE	DESCRIPTION
B	<b>NBR (Buna)</b> Std configuration without addition
V	For valve with <b>FPM (Viton)</b> o-ring seals, contact Sales Dept.

**5 Coils**

TYPE	CODE	DESCRIPTION
<b>BQP19 12VDC</b>	4SL5000126	12VDC-ISO4400 coil
<b>BH 12VDC</b>	4SLD001200	12VDC-ISO4400 coil

For complete coils list see from page 206

**6 Valve body**

TYPE	CODE	DESCRIPTION
<b>SAE 08/2-G 3/8</b>	3CC0820C11	Aluminium body for cavity 08 valve, G3/8 std thread
<b>SAE 10/2-G 3/8</b>	3CC1020C11	Aluminium body for cavity 10 valve, G3/8 std thread
<b>SAE 12/2-G 1/2</b>	3CC1220D11	Aluminium body for cavity 12 valve, G1/2 std thread
<b>SAE 16/2-G 3/4</b>	3CC1620E11	Aluminium body for cavity 16 valve, G3/4 std thread

Note: aluminium body can stand up to 210 bar (3050 psi)  
For steel bodies or different threading see from page 215

**7 Connector**

TYPE	CODE	DESCRIPTION
<b>ISO4400</b>	4CN1009995	Connector

For complete connectors list see from page 206

# Flow control valves

Flow control pressure compensated valves - 2 way

**PU..X type**

## Rating diagrams

**PU08X: pressure compensation diagram 1→2**  
for % of control current

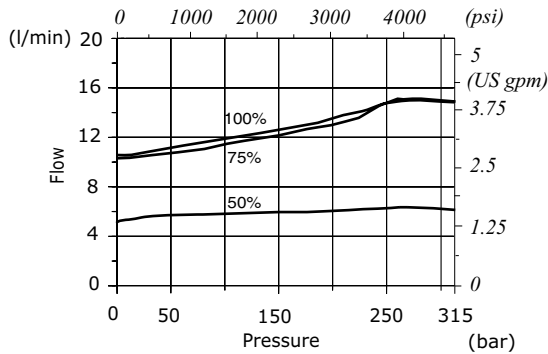

**PU08X**  
flow regulating vs. % max. control current

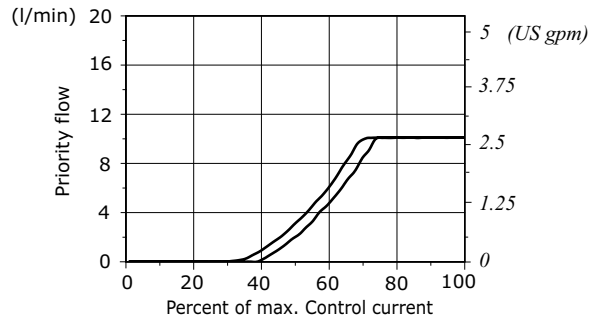

**PU10X: pressure compensation diagram 1→2**  
for % of control current

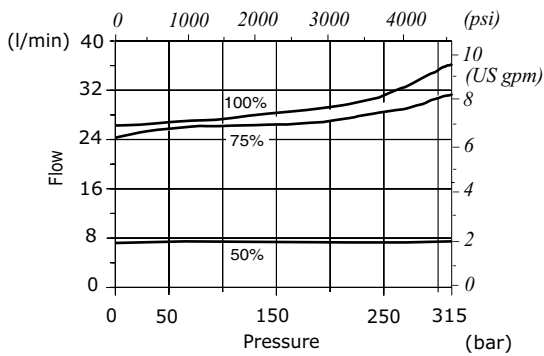

**PU10X**  
flow regulating vs. % max. control current

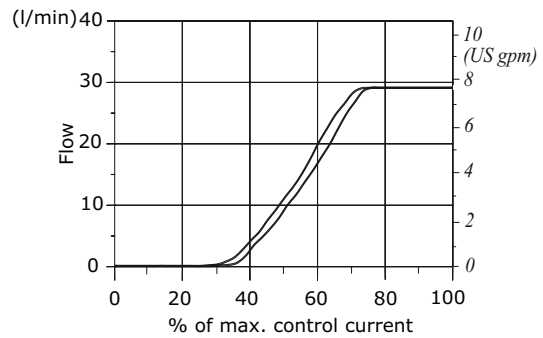

**PU12X: pressure compensation diagram 1→2**  
for % of control current

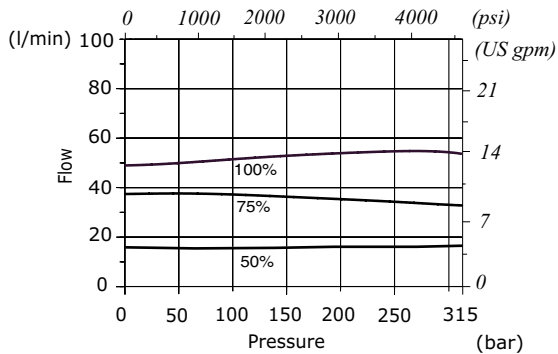

**PU12X**  
flow regulating vs. % max. control current

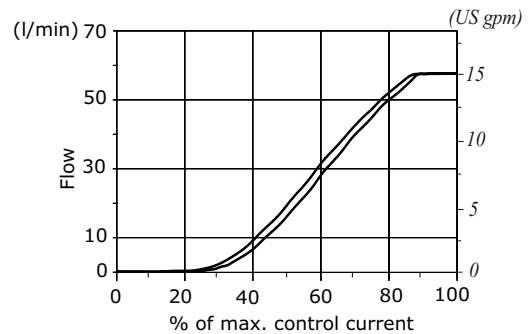

**PU16X: pressure compensation diagram 1→2**  
for % of control current

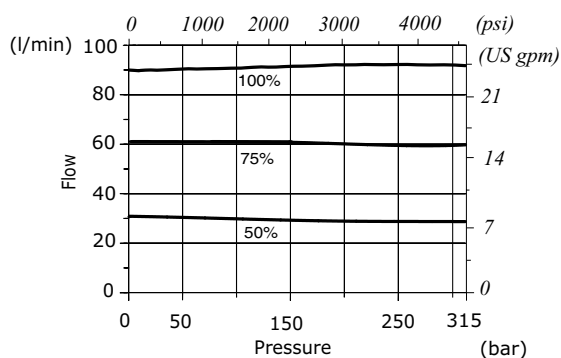

**PU16X**  
flow regulating vs. % max. control current

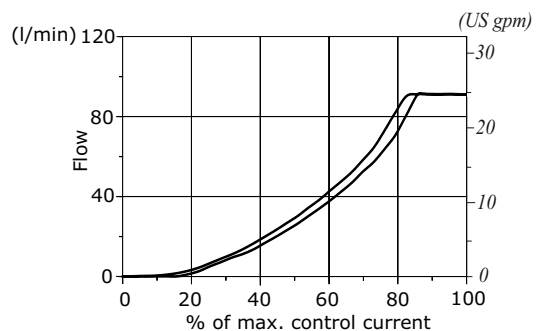







## PP..A type flow control pressure compensated valves - 3 way

- With exceeding flow to pressure
- From SAE08 to SAE16 cavities

Technical specifications and diagrams are measured with mineral oil of 46 cSt viscosity at 40°C (104°F) temperature.

	PP08A	PP10A	PP12A	PP16A
Nominal flow	Q1max= 20 l/min (5.2 US gpm)	50 l/min (13.2 US gpm)	90 l/min (23.8 US gpm)	150 l/min (39.6 US gpm)
	Q3max= 15 l/min (4 US gpm)	30 l/min (7.9 US gpm)	50 l/min (13 US gpm)	90 l/min (24 US gpm)
Max. pressure	350 bar (5100 psi)			
Fluid	mineral based oil			
Viscosity	10-200 cSt			
Max level of contamination	20/18/14 ISO4406			
Fluid temperature	with NBR seals	from -20°C (-4°F) to 80°C (176°F)		
	with FPM seals	from -20°C (-4°F) to 100°C (212°F)		
Environmental temp. for working conditions	from -20°C (-4°F) to 50°C (122°F)			
Cavity	SAE 08/3	SAE 10/3	SAE 12/3	SAE 16/3
Weight	0.15 kg (0.33 lb)	0.20 kg (0.44 lb)	0.42 kg (0.92 lb)	0.57 kg (1.26 lb)

NOTE - For different conditions, please contact Walvoil Sales Dpt.

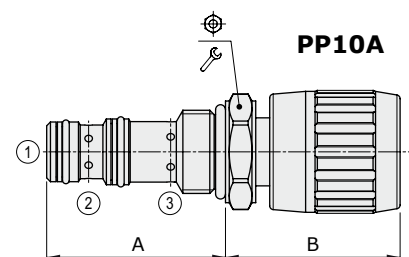
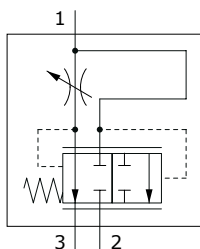

Valve type	A		B				Nm	lbft
	mm	in	mm	in				
PP08A/AM	41.1	1.62	49.5	1.95	24	30	22	
PP10A/AM	47.2	1.86	44	1.73	27	50	37	
PP12A/AM	73.5	2.89	45	1.77	32	80	59	
PP16A/AM	75	2.95	52	1.93	41	100	74	

For dimensions with different type of adjustment see page 212

Ordering codes and description composition

PP08A/AM0B

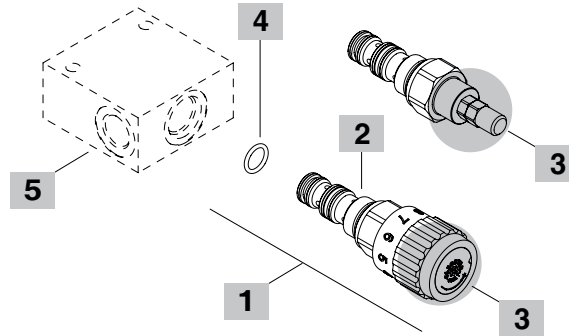
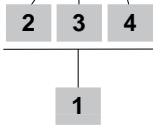

**1 Cartridges**

TYPE	CODE	DESCRIPTION
<b>SAE cavity 08/3</b>		
PP08A/AM0B	OPP08002000	Handknob adjustment
PP08A/AS0B	OPP08002004	Screw type adjustment
<b>SAE cavity 10/3</b>		
PP10A/AM0B	OPP10002000	Handknob adjustment
PP10A/AS0B	OPP10002005	Screw type adjustment
<b>SAE cavity 12/3</b>		
PP12A/AM0B	OPP12002000	Handknob adjustment
PP12A/AS0B	OPP12002004	Screw type adjustment
<b>SAE cavity 16/3</b>		
PP16A/AM0B	OPP16002001	Handknob adjustment
PP16A/AS0B	OPP16002006	Screw type adjustment

**2 Pressure drop from 1 to 2**

TYPE	DESCRIPTION
A	12 bar (170 psi)

**3 Adjustments**

TYPE	DESCRIPTION
S	Screw
M	Handknob

**4 Seals**

TYPE	DESCRIPTION
B	<b>NBR (Buna)</b> Std configuration without addition
V	For valve with <b>FPM (Viton)</b> o-ring seals, contact Sales Dept.

**5 Valve body**

TYPE	CODE	DESCRIPTION
<b>SAE 08/3-G 3/8</b>	3CC0830C11	Aluminium body for cavity 08 valve, G3/8 std thread
<b>SAE 10/3-G 3/8</b>	3CC1030C11	Aluminium body for cavity 10 valve, G3/8 std thread
<b>SAE 12/3-G 1/2</b>	3CC1230D11	Aluminium body for cavity 12 valve, G1/2 std thread
<b>SAE 16/3-G 3/4</b>	3CC1630E11	Aluminium body for cavity 16 valve, G3/4 std thread

Note: aluminium body can stand up to 210 bar (3050 psi)  
For steel bodies or different threading see from page 217

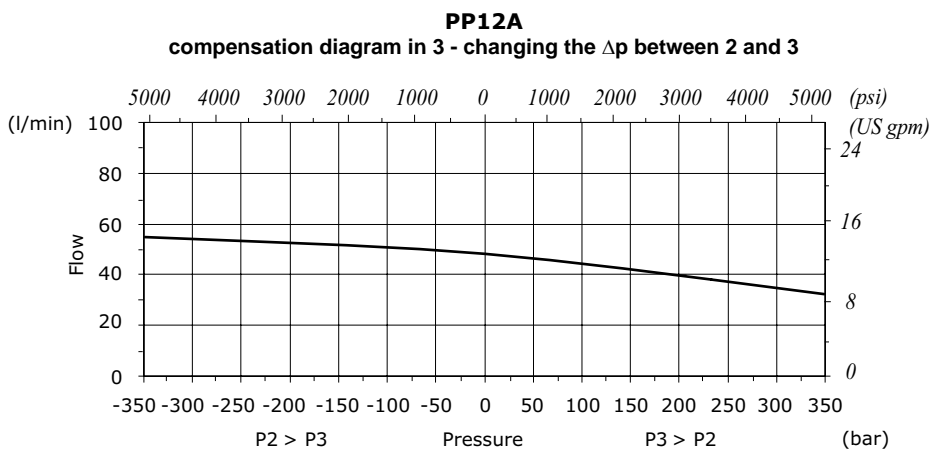
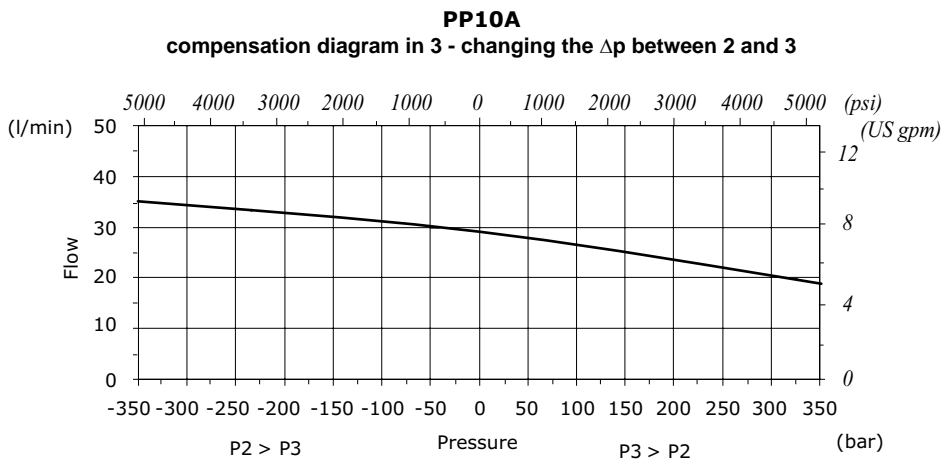
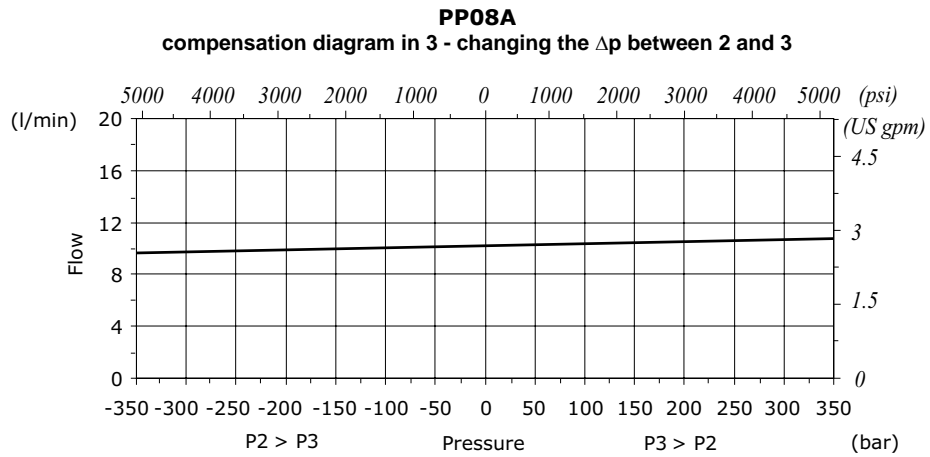

Rating diagrams

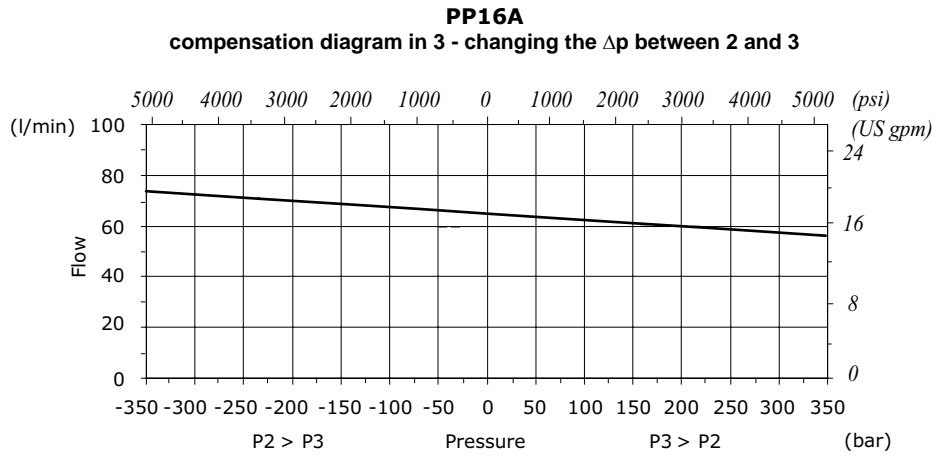



## PP..X type flow control pressure compensated valves - 3 way

- Solenoid proportional type
- With exceeding flow to pressure
- From SAE08 to SAE16 cavities

Technical specifications and diagrams are measured with mineral oil of 46 cSt viscosity at 40°C (104°F) temperature.

	PP08X	PP10X	PP12X	PP16X
Nominal flow	Q1max= 20 l/min (5.2 US gpm) Q3max= 15 l/min (3.9 US gpm)	50 l/min (13.2 US gpm) 30 l/min (8 US gpm)	90 l/min (23.8 US gpm) 60 l/min (16 US gpm)	150 l/min (39.6 US gpm) 90 l/min (23.8 US gpm)
Max. pressure	315 bar (4560 psi)			
Oil leakage	at 210 bar (3050 psi) 80 cm <sup>3</sup> /min (4.9 in <sup>3</sup> /min)	150 cm <sup>3</sup> /min (9.2 in <sup>3</sup> /min)	250 cm <sup>3</sup> /min (15.3 in <sup>3</sup> /min)	400 cm <sup>3</sup> /min (24.4 in <sup>3</sup> /min)
Fluid	mineral based oil			
Viscosity	10-200 cSt			
Max level of contamination	18/16/13 ISO4406			
Fluid temperature	with NBR seals with FPM seals	from -20°C (-4°F) to 80°C (176°F) from -20°C (-4°F) to 100°C (212°F)		
Environmental temp. for working conditions	from -20°C (-4°F) to 50°C (122°F)			
Cavity	SAE 08/3	SAE 10/3	SAE 12/3	SAE 16/3
Coil type*	BQP19 or BH			
Nominal voltages	12 VDC - 24 VDC ± 10%			
Power rating	20.4 W (BH) - 15 W (BQP19)			
Max control current	12 V -> 1.70 A - 24 V -> 0.85 A (BH) 12 V -> 1.25 A - 24 V -> 0.63 A (BQP19)			
Dither frequency	150 Hz			
Hysteresis	8%			
Weight	0.44 kg (0.97 lb)	0.49 kg (1.08 lb)	0.61 kg (1.34 lb)	1 kg (2.20 lb)

NOTE - For different conditions, please contact Walvoil Sales Dpt. - For coils further features see from page 206.

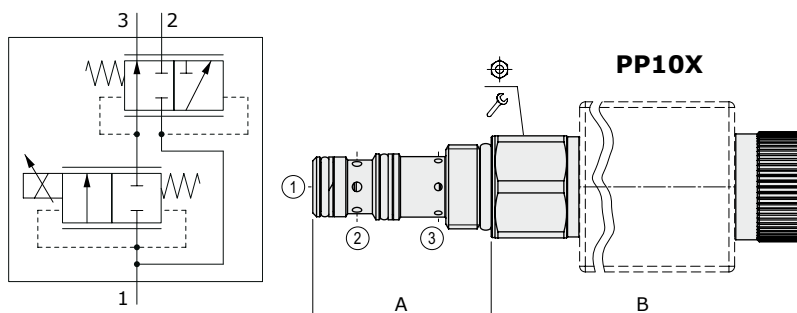

Valve type	A		B		⊕	⊕	Nm	lbft
	mm	in	mm	in				
PP08X/A0N	40.8	1.60	94	3.70	24	30	22	
PP10X/A0N	47.2	1.86	96.4	3.79	27	50	37	
PP12X/A0N	73.5	2.89	97.4	3.83	32	75	55	
PP16X/A0N	75.1	2.95	121.4	4.78	41	95	70	

For dimensions with different type of emergency see page 206

### Ordering codes and description composition

#### PP08X/A0NB

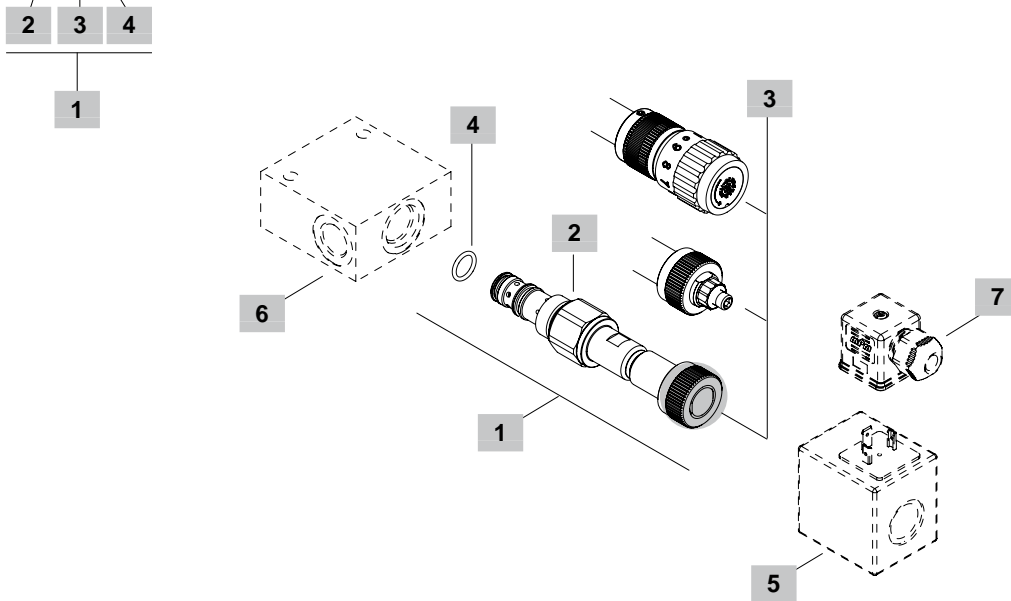

#### 1 Cartridges

TYPE	CODE	DESCRIPTION
<b>SAE cavity 08/3</b>		
PP08X/A0NB	0PP08002014	Without emergency
PP08X/A0TB	0PP08002015	Screw type emergency
PP08X/A0VB	0PP08002016	Handknob emergency
<b>SAE cavity 10/3</b>		
PP10X/A0NB	0PP10002031	Without emergency
PP10X/A0TB	0PP10002033	Screw type emergency
PP10X/A0VB	0PP10002035	Handknob emergency
<b>SAE cavity 12/3</b>		
PP12X/A0NB	0PP12002037	Without emergency
PP12X/A0TB	0PP12002039	Screw type emergency
PP12X/A0VB	0PP12002041	Handknob emergency
<b>SAE cavity 16/3</b>		
PP16X/A0NB	0PP16002013	Without emergency
PP16X/A0TB	0PP16002015	Screw type emergency
PP16X/A0VB	0PP16002014	Handknob emergency

#### 2 Pressure drop from 1 to 3

TYPE	DESCRIPTION
A	12 bar (170 psi)

#### 3 Emergency

TYPE	DESCRIPTION
N	Without emergency
T	Screw type
V	Handknob

#### 4 Seals

TYPE	DESCRIPTION
B	<b>NBR (Buna)</b> Std configuration without addition
V	For valve with <b>FPM (Viton)</b> o-ring seals, contact Sales Dept.

#### 5 Coils

TYPE	CODE	DESCRIPTION
BQP19 12VDC	4SL5000126	12VDC-ISO4400 coil
BH 12VDC	4SLD001200	12VDC-ISO4400 coil

For complete coils list see from page 206

#### 6 Valve body

TYPE	CODE	DESCRIPTION
SAE 08/3-G 3/8	3CC0830C11	Aluminium body for cavity 08 valve, G3/8 std thread
SAE 10/3-G 3/8	3CC1030C11	Aluminium body for cavity 10 valve, G3/8 std thread
SAE 12/3-G 1/2	3CC1230D11	Aluminium body for cavity 12 valve, G1/2 std thread
SAE 16/3-G 3/4	3CC1630E11	Aluminium body for cavity 16 valve, G3/4 std thread

Note: aluminium body can stand up to 210 bar (3050 psi)  
For steel bodies or different threading see from page 217

#### 7 Connector

TYPE	CODE	DESCRIPTION
ISO4400	4CN1009995	Connector

For complete connectors list see from page 206

**PP08X**  
**flow regulating vs. % max. control current**  
 $Q_{in} = \text{priority flow} + 30\%$

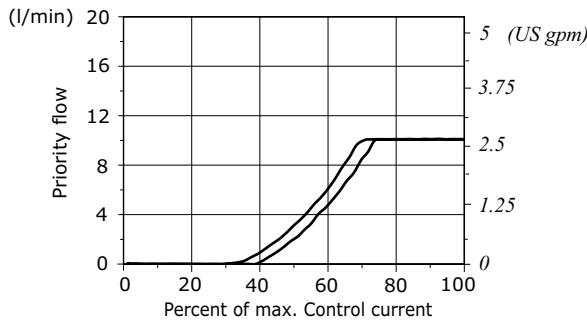

**PP08X**  
**pressure compensation diagram 2→3**  
 for % of control current

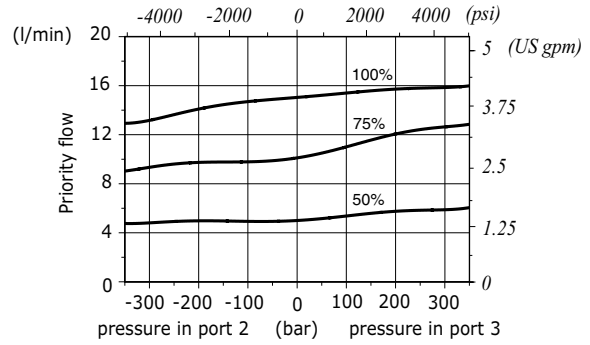

**PP08X**  
**pressure drop with de-energized coil**  
 from 1-→2

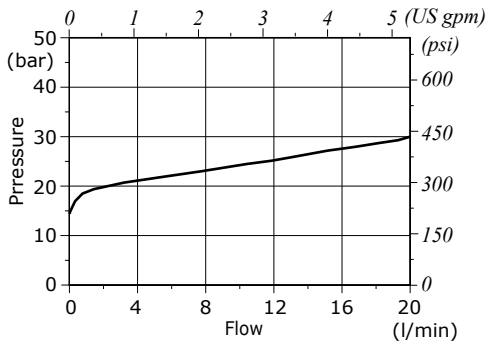

**PP10X**  
**flow regulating vs. % max. control current**  
 $Q_{in} = \text{priority flow} + 5\%$

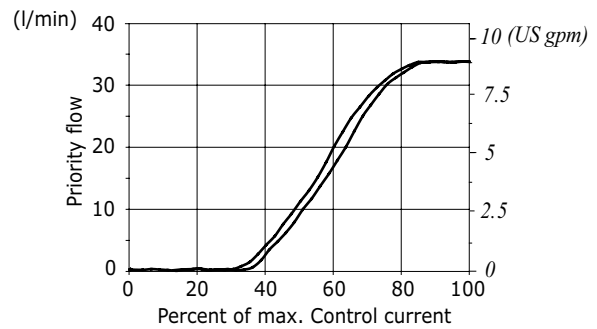

**PP10X**  
**pressure compensation diagram 2→3**  
 for % of control current

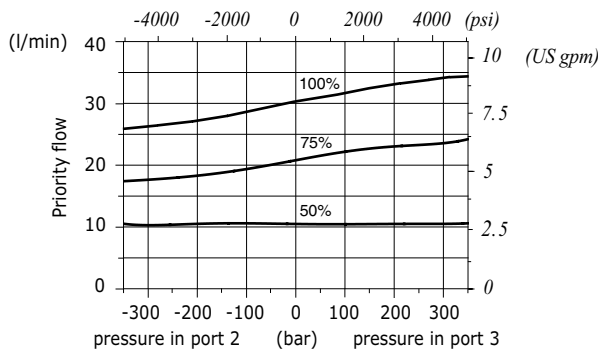

**PP10X**  
**pressure drop with de-energized coil**  
 from 1-→2

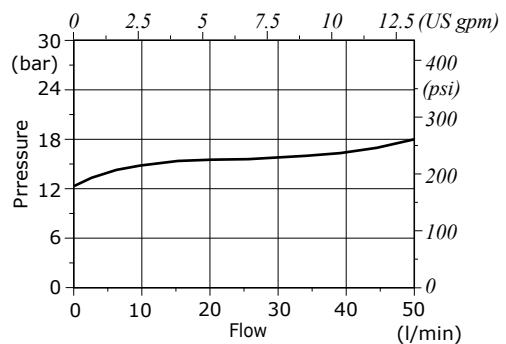

Rating diagrams

**PP12X**  
flow regulating vs. % max. control current  
 $Q_{in}$  = priority flow +15%

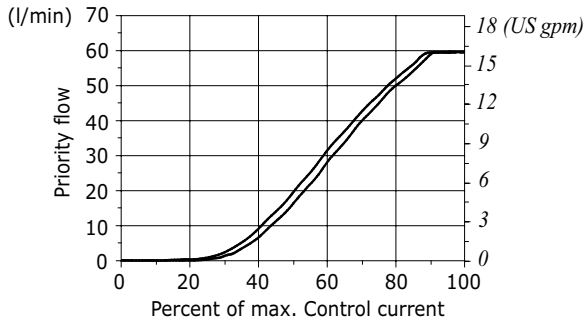

**PP12X**  
pressure compensation diagram 2→3  
for % of control current

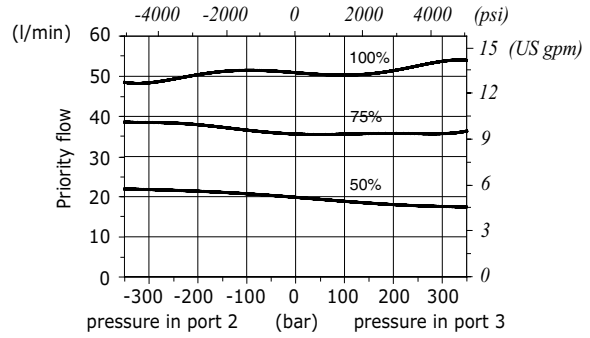

**PP12X**  
pressure drop with de-energized coil  
from 1->2

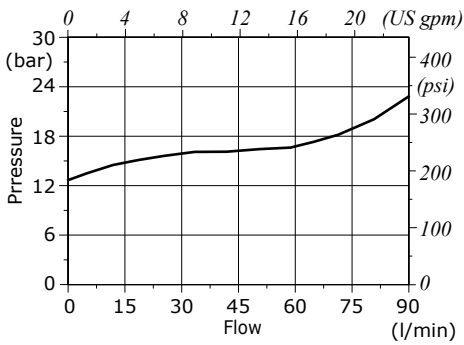

**PP16X**  
flow regulating vs. % max. control current  
 $Q_{in}$  = priority flow +10%

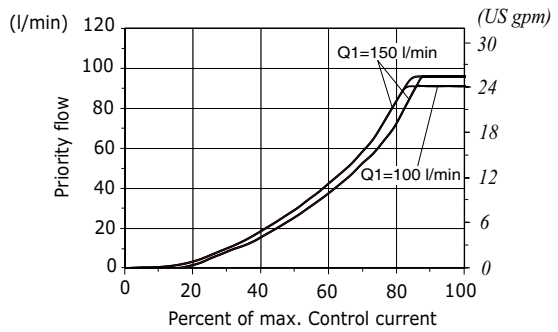

**PP16X**  
pressure compensation diagram 2→3  
for % of control current -  $Q_1=100$  l/min

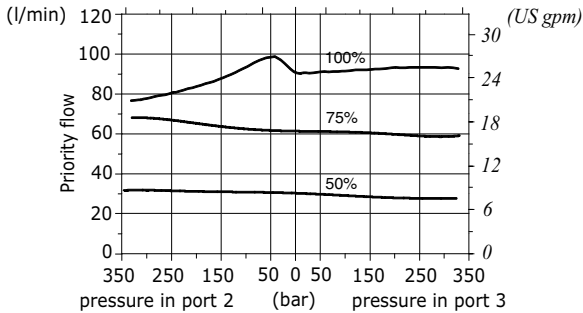

**PP16X**  
pressure drop with de-energized coil  
from 1->2

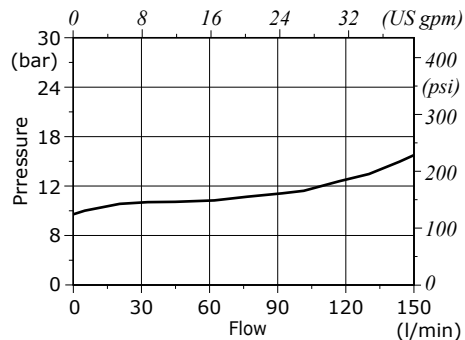





## PD... type flow control pressure compensated valves - 3 way

- Flow divider-combiners
- From SAE10 to SAE16 cavities

Technical specifications and diagrams are measured with mineral oil of 46 cSt viscosity at 40°C (104°F) temperature.

	PD10B/110B	PD10B/120B	PD10B/130B	PD10B/140B	PD10B/150B	PD12B/100B	PD16C/110B
Flow range	4-12 l/min (1-3 US gpm)	12-20 l/min (3-5 US gpm)	20-28 l/min (5-7 US gpm)	28-36 l/min (7-9 US gpm)	36-44 l/min (9-12 US gpm)	40-75 l/min (10-20 US gpm)	75-150 l/min (20-40 US gpm)
Max. pressure	210 bar (3045 psi)						
Maximum division error	± 5% of the oil flow in 1 or 3 and 120 bar -1750 psi- pressure difference between 1 and 3. (Division rate 50%÷50%)						
Fluid	mineral based oil						
Viscosity	10-200 cSt						
Max level of contamination	20/18/14 ISO4406						
Fluid temperature	with NBR seals		from -20°C (-4°F) to 80°C (176°F)				
	with FPM seals		from -20°C (-4°F) to 100°C (212°F)				
Environmental temp. for working conditions	from -20°C (-4°F) to 50°C (122°F)						
Cavity	SAE 10/4	SAE 10/4	SAE 10/4	SAE 10/4	SAE 10/4	SAE 12/4	SAE 16/4
Weight	0.20 kg (0.44 lb)	0.20 kg (0.44 lb)	0.20 kg (0.44 lb)	0.20 kg (0.44 lb)	0.20 kg (0.44 lb)	0.30 kg (0.66 lb)	0.55 kg (1.21 lb)

NOTE - For different conditions, please contact Walvoil Sales Dpt.

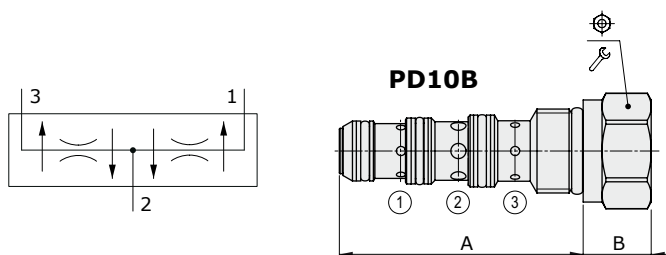

Valve type	A		B		Nm	lbft
	mm	in	mm	in		
PD10B	64.5	2.54	18	0.71	27	50
PD12B	83	3.27	12	0.47	32	80
PD16C	104	4.09	17	0.69	41	100

### Ordering codes and description composition

#### PD10B/110B

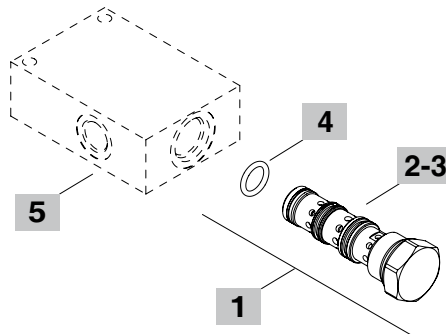
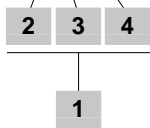

#### 4 Cartridges

TYPE	CODE	DESCRIPTION
<b>SAE cavity 10/4</b>		
PD10B/110B	OPD10002004	Flow range 1
PD10B/120B	OPD10002005	Flow range 2
PD10B/130B	OPD10002006	Flow range 3
PD10B/140B	OPD10002007	Flow range 4
PD10B/150B	OPD10002008	Flow range 5
<b>SAE cavity 12/4</b>		
PD12B/100B	OPD12002001	Range 40÷75 l/min (10-20 US gpm)
<b>SAE cavity 16/4</b>		
PD16C/100B	OPD16002003	Range 75÷150 l/min (20-40 US gpm)

#### 3 Seals

TYPE	DESCRIPTION
<b>B</b>	<b>NBR (Buna)</b> Std configuration without addition
<b>V</b>	For valve with <b>FPM (Viton)</b> o-ring seals, contact Sales Dept.

#### 6 Valve body

TYPE	CODE	DESCRIPTION
<b>SAE 10/4-G 3/8</b>	3CC1040C11	Aluminium body for cavity 10 valve, G3/8 std thread
<b>SAE 12/4-G 1/2</b>	3CC1240D11	Aluminium body for cavity 12 valve, G1/2 std thread
<b>SAE 16/4-G 3/4</b>	3CC1640E11	Aluminium body for cavity 16 valve, G3/4 std thread

Note: aluminium body can stand up to 210 bar (3050 psi)  
For steel bodies or different threading see from page 219

#### 1 Dividing-Combining ratio

TYPE	DESCRIPTION
1	50÷50

#### 2 Flow range

TYPE	DESCRIPTION
1	4÷12 l/min (1-3 US gpm)
2	12÷20 l/min (3-5 US gpm)
3	20÷28 l/min (5-7 US gpm)
4	28÷36 l/min (7-9 US gpm)
5	36÷44 l/min (9-12 US gpm)

### Rating diagrams

**PD10B**  
pressure drop vs flow  
form 2->1/3 and from 1/3->2

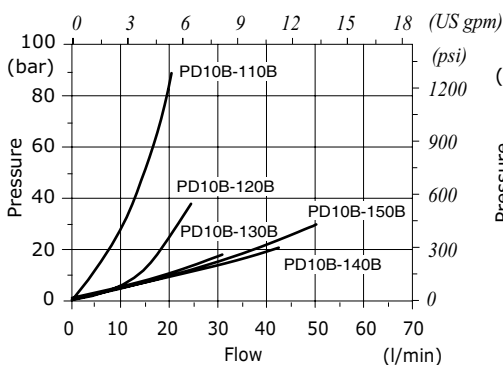

**PD12B**  
pressure drop vs flow  
from 2->1/3 and from 1/3->2

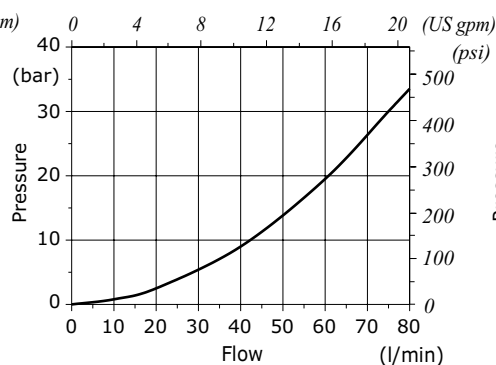

**PD16C**  
pressure drop vs flow  
from 2->1/3 and from 1/3->2

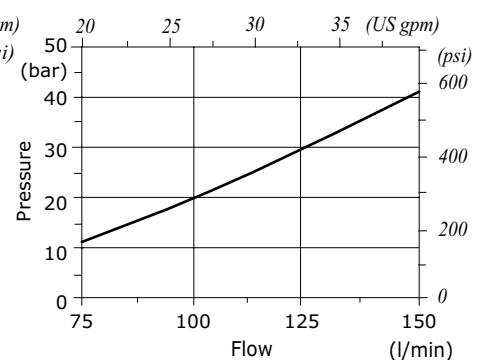



## LA..QA type logic element - 3 way

- Pilot to close configuration
- Fixed or adjustable Stand-by
- SAE10 and SAE16 cavities

Technical specifications and diagrams are measured with mineral oil of 46 cSt viscosity at 40°C (104°F) temperature.

	LA10QA	LA16QA
Nominal flow	80 l/min (21 US gpm)	190 l/min (50 US gpm)
Max. pressure	350 bar (5100 psi)	
Opening pressure	fixed setting: 1, 5, 10 bar (14.5, 72.5, 145 psi) adjustable setting: from 8 to 15 bar (116 to 218 psi)	
Oil leakage at 210 bar (3050 psi)	80 cm <sup>3</sup> /min (4.88 in <sup>3</sup> /min)	230 cm <sup>3</sup> /min (14.03 in <sup>3</sup> /min)
Fluid	mineral based oil	
Viscosity	10-200 cSt	
Max level of contamination	20/18/14 ISO4406	
Fluid temperature	with NBR seals with FPM seals	from -20°C (-4°F) to 80°C (176°F) from -20°C (-4°F) to 100°C (212°F)
Environmental temp. for working conditions	from -20°C (-4°F) to 50°C (122°F)	
Cavity	SAE 10/3Q	SAE 16/3Q
Weight	0.15 kg (0.33 lb)	0.45 kg (0.99 lb)

NOTE - For different conditions, please contact Walvoil Sales Dpt.

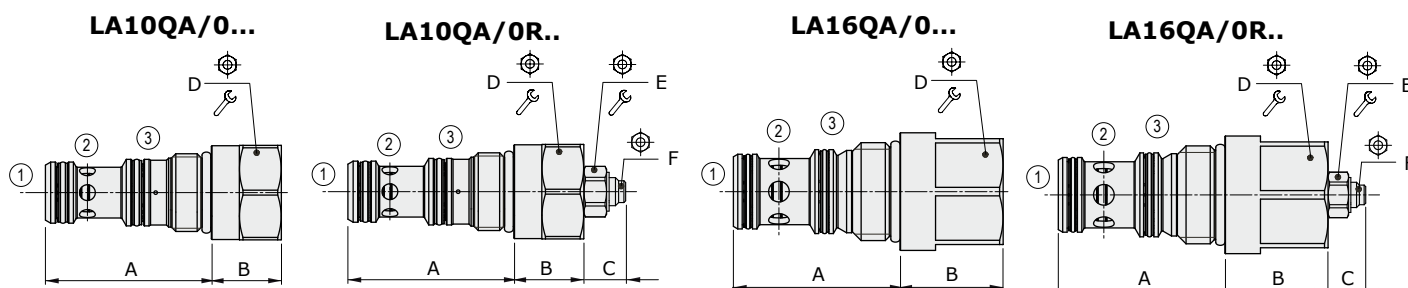
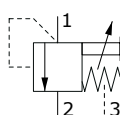

Valve type	A		B		C (max)		D			E		F	
	mm	in	mm	in	mm	in	mm	Nm	lbft	mm	Nm	lbft	mm
LA10QA	47.6	1.87	20	0.79	21	0.83	27	70	52	13	9.8	7.2	3
LA16QA	56.9	2.24	35.1	1.38	24	0.94	36	100	74	13	9.8	7.2	3

Ordering codes and description composition

LA 10QA/0 C 0 B SB=12bar

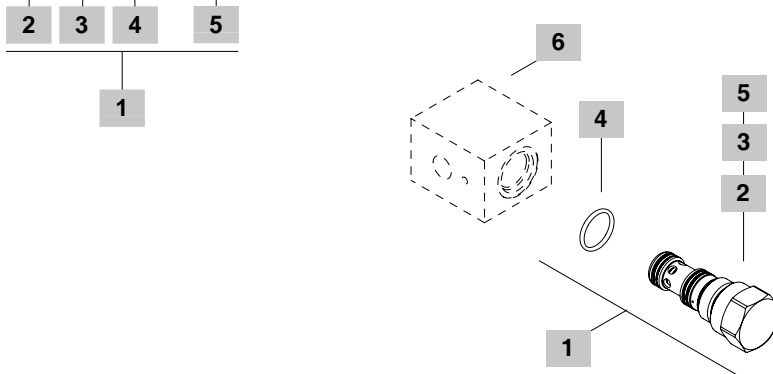

**1 Cartridge**

TYPE	CODE	DESCRIPTION
<b>SAE cavity 10/30</b>		
LA10QA/0B0B	0LA10Q002003	Fixed setting, 5 bar (72.5 psi)
LA10QA/0C0B	0LA10Q002001	Fixed setting, 10 bar (145 psi)
LA10QA/0R0B SB=12bar	0LA10Q002002	Adjustable setting, std setting 12 bar (174 psi)
<b>SAE cavity 16/30</b>		
LA16QA/0C0B	0LA16Q002000	Fixed setting, 10 bar (145 psi)
LA16QA/0R0B SB=12bar	0LA16Q002001	Adjustable setting, std setting 12 bar (174 psi)

**2 Stand by**

Setting is referred to 1 l/min (0.26 US gpm) flow

TYPE	DESCRIPTION
A	Fixed setting: 1 bar (14.5 psi)
B	Fixed setting: 5 bar (72.5 psi)
C	Fixed setting: 10 bar (145 psi)
R	Adjustable setting: from 8 to 15 bar (116 to 218 psi)

**3 Lead sealing**

TYPE	DESCRIPTION
0	Without sealing
X	With sealing: for valves with adjustable stand-by only

**4 Seals**

TYPE	DESCRIPTION
B	NBR (Buna) o-ring seals, std configuration
V	FPM (Viton) o-ring seals, contact Sales Dept.

**5 Stand-by setting**

To be specified only with adjustable stand-by valve

**6 Valve body**

TYPE	CODE	DESCRIPTION
SAE 10/3Q-G 1/2	3CC1032D21	Steel body for cavity 08 valve, G 1/2 standard thread
SAE 16/3Q-G 3/4	3CC1632E21	Steel body for cavity 16 valve, G 3/4 standard thread

For aluminium bodies or different threading see from page 217

Rating diagrams

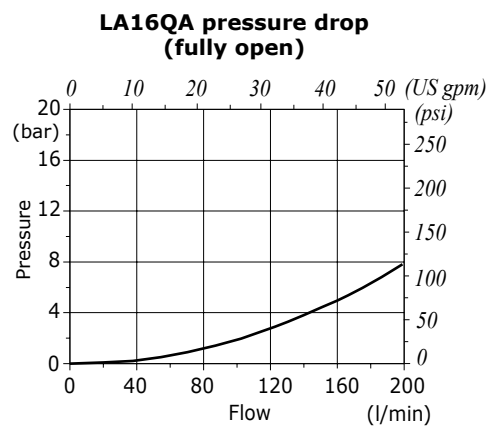
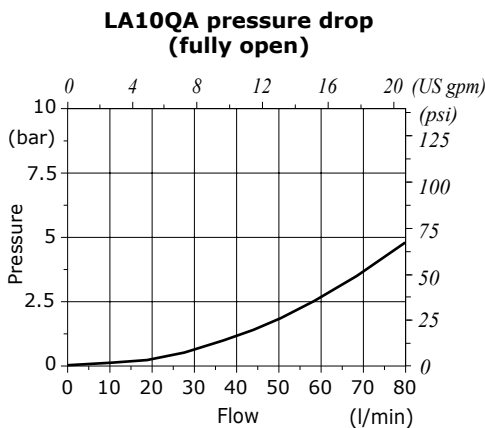



## LB..QA type logic element - 3 way

- Venting to open configuration
- Fixed or adjustable Stand-by
- SAE10 and SAE16 cavities

Technical specifications and diagrams are measured with mineral oil of 46 cSt viscosity at 40°C (104°F) temperature.

	LB10QA	LB16QA
Nominal flow	80 l/min (21 US gpm)	190 l/min (50 US gpm)
Max. pressure	350 bar (5100 psi)	
Opening pressure	fixed setting: 5, 10 bar (72.5, 145 psi) adjustable setting: from 8 to 15 bar (116 to 218 psi)	
Oil leakage at 210 bar (3050 psi)	80 cm <sup>3</sup> /min (4.88 in <sup>3</sup> /min)	230 cm <sup>3</sup> /min (14.03 in <sup>3</sup> /min)
Fluid	mineral based oil	
Viscosity	10-200 cSt	
Max level of contamination	20/18/14 ISO4406	
Fluid temperature	with NBR seals with FPM seals	from -20°C (-4°F) to 80°C (176°F) from -20°C (-4°F) to 100°C (212°F)
Environmental temp. for working conditions	from -20°C (-4°F) to 50°C (122°F)	
Cavity	SAE 10/3Q	SAE 16/3Q
Weight	0.15 kg (0.33 lb)	0.45 kg (0.99 lb)

NOTE - For different conditions, please contact Walvoil Sales Dpt.

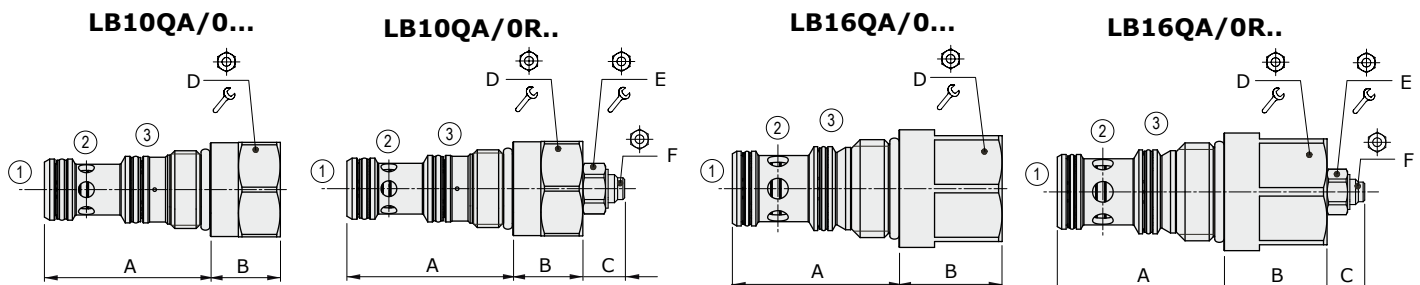
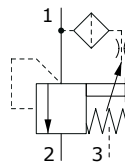

Valve type	A		B		C (max)		D			E		F	
	mm	in	mm	in	mm	in	Ø	Nm	lbft	Ø	Nm	lbft	Ø
LB10QA	47.6	1.87	20	0.79	21	0.83	27	70	52	13	9.8	7.2	3
LB16QA	56.9	2.24	35.1	1.38	24	0.94	36	100	74	13	9.8	7.2	3

## Ordering codes and description composition

LB 10QA/0 B 0 B SB=12bar

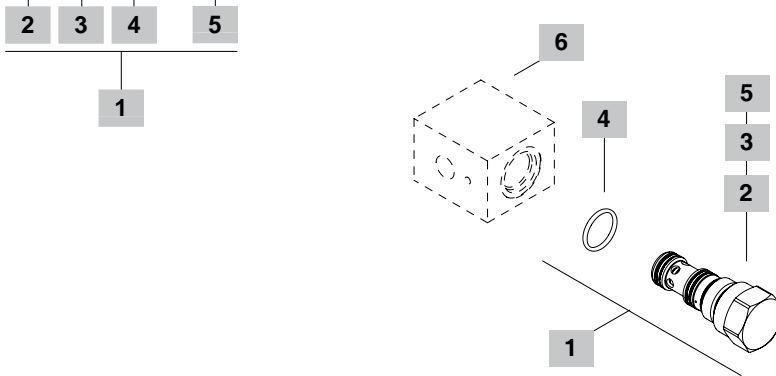

### 1 Cartridge

TYPE	CODE	DESCRIPTION
<b>SAE cavity 10/3Q</b>		
<b>LB10QA/0B0B</b>	0LB10Q002000	Fixed setting, 5 bar (72.5 psi)
<b>SAE cavity 16/3Q</b>		
<b>LB16QA/0B0B</b>	0LB16Q002000	Fixed setting, 5 bar (72.5 psi)

### 2 Stand by

Setting is referred to 1 l/min (0.26 US gpm) flow

TYPE	DESCRIPTION
<b>B</b>	Fixed setting: 5 bar (72.5 psi)
<b>C</b>	Fixed setting: 10 bar (145 psi)
<b>R</b>	Adjustable setting: from 8 to 15 bar (116 to 218 psi)

### 3 Lead sealing

TYPE	DESCRIPTION
<b>0</b>	Without sealing
<b>X</b>	With sealing: for valves with adjustable stand-by only

### 4 Seals

TYPE	DESCRIPTION
<b>B</b>	<b>NBR (Buna)</b> o-ring seals, std configuration
<b>V</b>	<b>FPM (Viton)</b> o-ring seals, contact Sales Dept.

### 5 Stand-by setting

To be specified only with adjustable stand-by valve

### 6 Valve body

TYPE	CODE	DESCRIPTION
<b>SAE 10/3Q-G 1/2</b>	3CC1032D21	Steel body for cavity 08 valve, G 1/2 standard thread
<b>SAE 16/3Q-G 3/4</b>	3CC1632E21	Steel body for cavity 16 valve, G 3/4 standard thread

For aluminium bodies or different threading see from page 217

## Rating diagrams

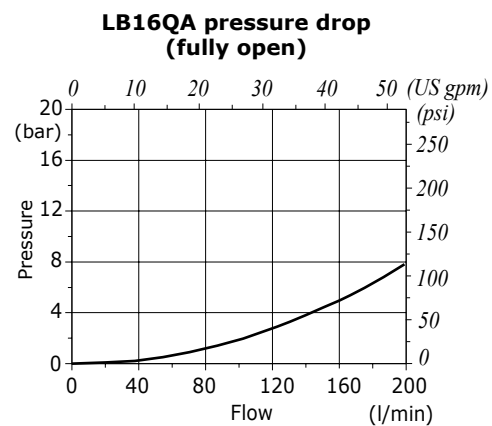
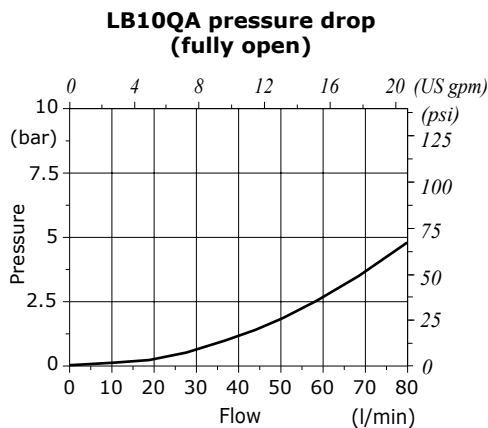



## LC..QA type logic element - 3 way

- Venting to close configuration
- Fixed or adjustable Stand-by
- SAE10 and SAE16 cavities

Technical specifications and diagrams are measured with mineral oil of 46 cSt viscosity at 40°C (104°F) temperature.

	LC10QA	LC16QA
Nominal flow	60 l/min (16 US gpm)	150 l/min (39.6 US gpm)
Max. pressure	350 bar (5100 psi)	
Opening pressure	fixed setting: 5, 10 bar (72.5, 145 psi) adjustable setting: from 8 to 15 bar (116 to 218 psi)	
Oil leakage	at 210 bar (3050 psi) 80 cm <sup>3</sup> /min (4.88 in <sup>3</sup> /min)	230 cm <sup>3</sup> /min (14.03 in <sup>3</sup> /min)
Fluid	mineral based oil	
Viscosity	10-200 cSt	
Max level of contamination	20/18/14 ISO4406	
Fluid temperature	with NBR seals with FPM seals	from -20°C (-4°F) to 80°C (176°F) from -20°C (-4°F) to 100°C (212°F)
Environmental temp. for working conditions	from -20°C (-4°F) to 50°C (122°F)	
Cavity	SAE 10/3Q	SAE 16/3Q
Weight	0.15 kg (0.33 lb)	0.45 kg (0.99 lb)

NOTE - For different conditions, please contact Walvoil Sales Dpt.

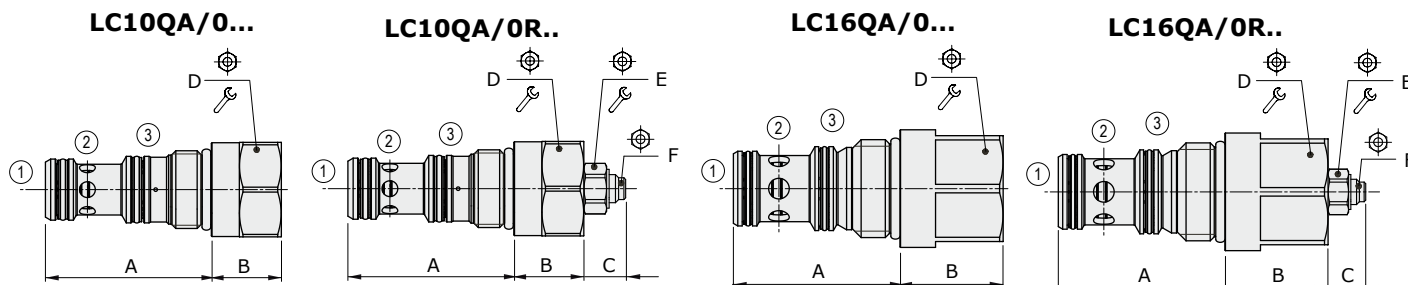
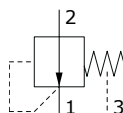

Valve type	A		B		C (max)		D			E		F	
	mm	in	mm	in	mm	in		Nm	lbft		Nm	lbft	
LC10QA	47.6	1.87	20	0.79	21	0.83	27	70	52	13	9.8	7.2	3
LC16QA	56.9	2.24	35.1	1.38	24	0.94	36	100	74	13	9.8	7.2	3

Ordering codes and description composition

LC 10QA/0 B 0 B SB=12bar

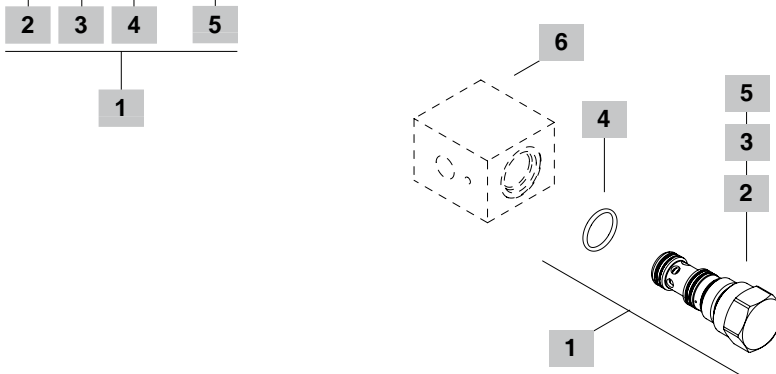

1 Cartridge		
TYPE	CODE	DESCRIPTION
<b>SAE cavity 10/3Q</b>		
LC10QA/0B0B	0LC10Q002001	Fixed setting, 5 bar (72.5 psi)
<b>SAE cavity 16/3Q</b>		
LC16QA/0B0B	0LC16Q002001	Fixed setting, 5 bar (72.5 psi)

2 Stand by	
TYPE	DESCRIPTION
B	Fixed setting: 5 bar (72.5 psi)
C	Fixed setting: 10 bar (145 psi)
R	Adjustable setting: from 8 to 15 bar (116 to 218 psi)

3 Lead sealing	
TYPE	DESCRIPTION
0	Without sealing
X	With sealing: for valves with adjustable stand-by only

4 Seals	
TYPE	DESCRIPTION
B	NBR (Buna) o-ring seals, std configuration
V	FPM (Viton) o-ring seals, contact Sales Dept.

**5 Stand-by setting**  
To be specified only with adjustable stand-by valve

6 Valve body		
TYPE	CODE	DESCRIPTION
SAE 10/3Q-G 1/2	3CC1032D21	Steel body for cavity 08 valve, G 1/2 standard thread
SAE 16/3Q-G 3/4	3CC1632E21	Steel body for cavity 16 valve, G 3/4 standard thread

For aluminium bodies or different threading see from page 217

Rating diagrams

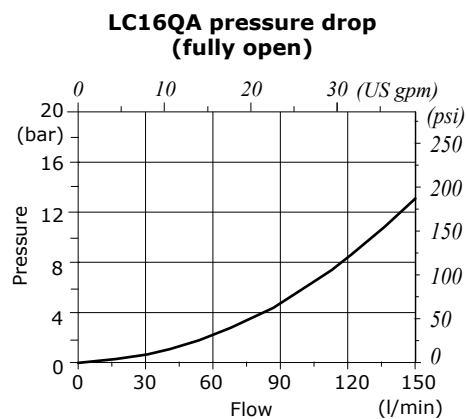
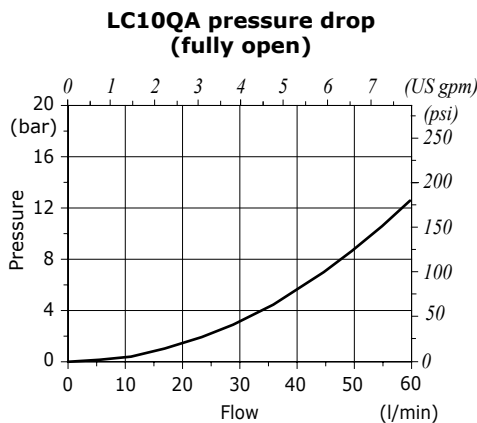





## LD..QA type logic element - 3 way

- Pilot to open configurationj
- Fixed or adjustable Stand-by
- SAE10 and SAE16 cavities

Technical specifications and diagrams are measured with mineral oil of 46 cSt viscosity at 40°C (104°F) temperature.

	LD10QA	LD16QA
Nominal flow	60 l/min (16 US gpm)	150 l/min (39.6 US gpm)
Max. pressure	350 bar (5100 psi)	
Opening pressure	fixed setting: 1, 5, 10 bar (14.5, 72.5, 145 psi) adjustable setting: from 8 to 15 bar (116 to 218 psi)	
Oil leakage at 210 bar (3050 psi)	80 cm <sup>3</sup> /min (4.88 in <sup>3</sup> /min)	230 cm <sup>3</sup> /min (14.03 in <sup>3</sup> /min)
Fluid	mineral based oil	
Viscosity	10-200 cSt	
Max level of contamination	20/18/14 ISO4406	
Fluid temperature	with NBR seals with FPM seals	from -20°C (-4°F) to 80°C (176°F) from -20°C (-4°F) to 100°C (212°F)
Environmental temp. for working conditions	from -20°C (-4°F) to 50°C (122°F)	
Cavity	SAE 10/3Q	SAE 16/3Q
Weight	0.15 kg (0.33 lb)	0.45 kg (0.99 lb)

NOTE - For different conditions, please contact Walvoil Sales Dpt.

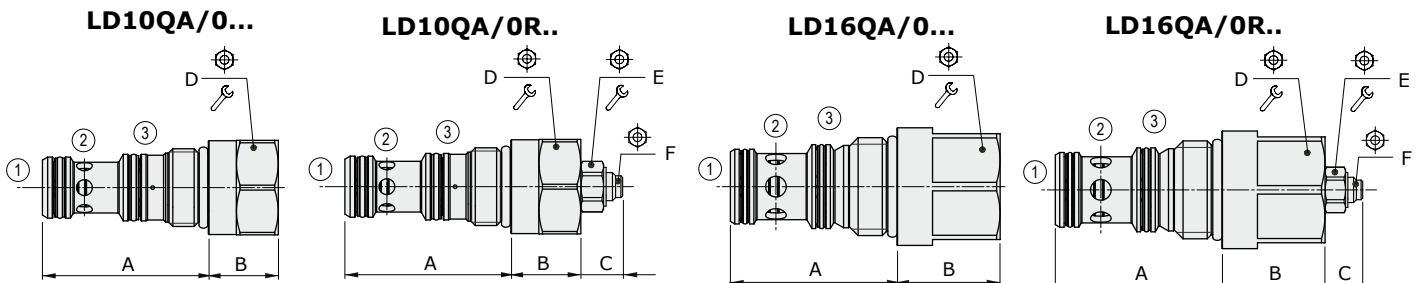
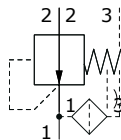

Valve type	A		B		C (max)		D			E		F	
	mm	in	mm	in	mm	in							
LD10QA	47.6	1.87	20	0.79	21	0.83	27	70	52	13	9.8	7.2	3
LD16QA	56.9	2.24	35.1	1.38	24	0.94	36	100	74	13	9.8	7.2	3

Ordering codes and description composition

LD 10QA/0 B 0 B SB=12bar

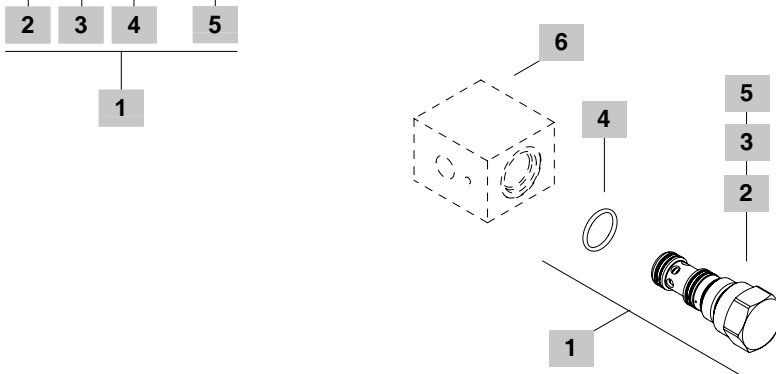

1 Cartridge		
TYPE	CODE	DESCRIPTION
<b>SAE cavity 10/3Q</b>		
LD10QA/0B0B	OLD10Q002000	Fixed setting, 5 bar (72.5 psi)
<b>SAE cavity 16/3Q</b>		
LD16QA/0B0B	OLD16Q002000	Fixed setting, 5 bar (72.5 psi)

2 Stand by	
TYPE	DESCRIPTION
A	Fixed setting: 1 bar (14.5 psi)
B	Fixed setting: 5 bar (72.5 psi)
C	Fixed setting: 10 bar (145 psi)
R	Adjustable setting: from 8 to 15 bar (116 to 218 psi)

3 Lead sealing	
TYPE	DESCRIPTION
0	Without sealing
X	With sealing: for valves with adjustable stand-by only

4 Seals	
TYPE	DESCRIPTION
B	NBR (Buna) o-ring seals, std configuration
V	FPM (Viton) o-ring seals, contact Sales Dept.

5 Stand-by setting	
To be specified only with adjustable stand-by valve	

6 Valve body		
TYPE	CODE	DESCRIPTION
SAE 10/3Q-G 1/2	3CC1032D21	Steel body for cavity 08 valve, G 1/2 standard thread
SAE 16/3Q-G 3/4	3CC1632E21	Steel body for cavity 16 valve, G 3/4 standard thread

For aluminium bodies or different threading see from page 217

Rating diagrams

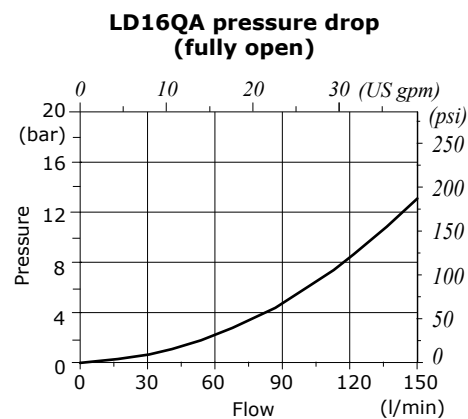
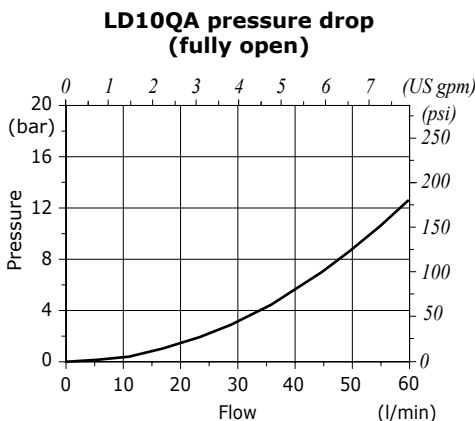



## EA08 type directional solenoid valve - 2 way / 2 positions

- Direct acting
- Poppet type
- Normally open and closed configurations

Technical specifications and diagrams are measured with mineral oil of 46 cSt viscosity at 40°C (104°F) temperature.

	EA08A	EA08B
Nominal flow	1 l/min (0.26 US gpm)	1 l/min (0.26 US gpm)
Max. pressure	210 bar (3050 psi)	350 bar (5100 psi)
Oil leakage	at 210 bar (3050 psi) 0.25 cm <sup>3</sup> /min (0.015 in <sup>3</sup> /min)	
Fluid	mineral based oil	
Viscosity	10-200 cSt	
Max level of contamination	18/16/13 ISO4406	
Fluid temperature	with NBR seals with FPM seals	from -20°C (-4°F) to 80°C (176°F) from -20°C (-4°F) to 100°C (212°F)
Environmental temp. for working conditions	from -20°C (-4°F) to 50°C (122°F)	
Cavity	SAE 8/2	
Coil type*	BE	BT
Nominal voltages	12 VDC - 24 VDC ± 10%	12 VDC - 24 VDC ± 10%
Power rating	18.7 W (12 VDC) 18.6 W (24 VDC)	21 W (12-24 VDC)
Weight	0.130 kg (0.28 lb)	0.130 kg (0.28 lb)

NOTE - For different conditions, please contact Walvoil Sales Dpt. - \*For coils further features see from page 206.

### Normally open configuration

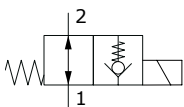

### Normally closed configuration

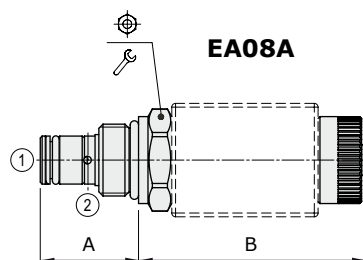
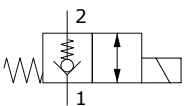

Valve type	A		B				Nm	lbft
	mm	in	mm	in				
EA08A/	10NB	27.5	1.08	60	2.36	24	30	22
	20NB	27.5	1.08	59	2.32	24	30	22
EA08B/	10NB	27.5	1.08	70.9	2.79	24	30	22
	20NB	27.5	1.08	65.5	2.58	24	30	22

For dimensions with different type of emergency see page 213

### Ordering codes and description composition

#### EA08A/10 NB

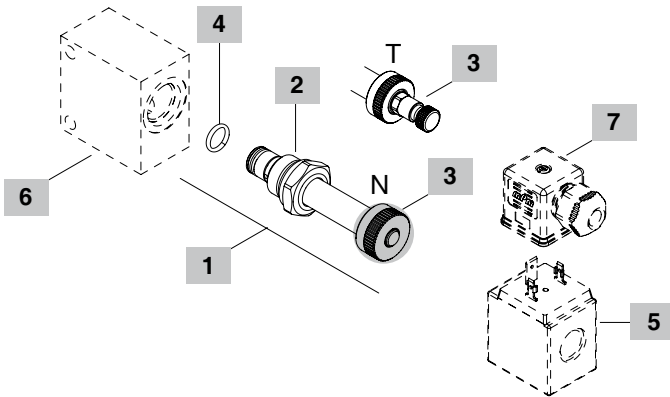
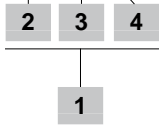

#### 1 Cartridges

TYPE	CODE	DESCRIPTION
<b>SAE cavity 08/2</b>		
<b>EA08A/10NB</b>	0EA08002001	Normally open configuration (N.O.) without emergency
<b>EA08B/10NB</b>	0EA08002003	(N.O.) without emergency
<b>EA08A/10TB</b>	0EA08002007	(N.O.) screw type emergency
<b>EA08B/10TB</b>	0EA08002005	(N.O.) screw type emergency
<b>EA08A/20NB</b>	0EA08002000	Normally closed configuration (N.C.) without emergency
<b>EA08B/20NB</b>	0EA08002002	(N.C.) without emergency
<b>EA08A/20TB</b>	0EA08002009	(N.C.) screw type emergency
<b>EA08B/20TB</b>	0EA08002004	(N.C.) screw type emergency

#### 2 Spool

TYPE	DESCRIPTION
<b>1</b>	Normally open configuration
<b>2</b>	Normally closed configuration

#### 3 Emergency

TYPE	DESCRIPTION
<b>N</b>	Without emergency
<b>T</b>	Screw type

Note: for configurations with different emergency contact Sales Dept.

#### 4 Seals

TYPE	DESCRIPTION
<b>B</b>	<b>NBR (Buna)</b> o-ring seals, std configuration
<b>V</b>	<b>FPM (Viton)</b> o-ring seals, contact Sales Dept.

#### 5 Coils

TYPE	CODE	DESCRIPTION
<b>BE 12VDC</b>	4SL1000120	12VDC-ISO4400 coil for EA08A
<b>BT 12VDC</b>	4SL3000120	12VDC-ISO4400 coil for EA08B

For complete coils list see page 206

#### 6 Valve body

TYPE	CODE	DESCRIPTION
<b>SAE 08/2-G 1/4</b>	3CC0820B11	Aluminium body for cavity 08 valve, G1/4 std thread

Note: aluminium body can stand up to 210 bar (3050 psi)  
For steel bodies or different threading see from page 215

#### 7 Connector

TYPE	CODE	DESCRIPTION
<b>ISO4400</b>	4CN1009995	Connector

For complete connectors list see page 206

### Rating diagrams

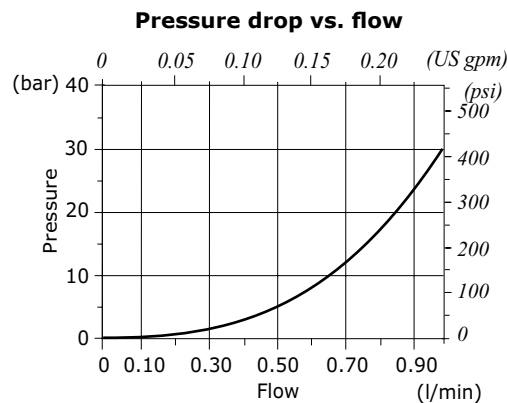



## EE..A type directional solenoid valves - 2 way / 2 positions

- Direct acting
- Spool type
- Normally open and closed configurations
- From SAE08 to SAE12 cavities

Technical specifications and diagrams are measured with mineral oil of 46 cSt viscosity at 40°C (104°F) temperature.

	EE08A	EE10A	EE12A
Nominal flow	8 l/min (2.11 US gpm)	30 l/min (7.9 US gpm)	40 l/min (10.5 US gpm)
Max. pressure	210 bar (3050 psi)		
Oil leakage	at 210 bar (3050 psi) 30 cm <sup>3</sup> /min (1.83 in <sup>3</sup> /min)	55 cm <sup>3</sup> /min (3.35 in <sup>3</sup> /min)	75 cm <sup>3</sup> /min (4.58 in <sup>3</sup> /min)
Fluid	mineral based oil		
Viscosity	10-200 cSt		
Max level of contamination	18/16/13 ISO4406		
Fluid temperature	with NBR seals with FPM seals	from -20°C (-4°F) to 80°C (176°F) from -20°C (-4°F) to 100°C (212°F)	
Environmental temp. for working conditions	from -20°C (-4°F) to 50°C (122°F)		
Cavity	SAE 08/2	SAE 10/2	SAE 12/2
Coil type*	BER	BIN 19	BIN 22
Nominal voltages	12 VDC - 24 VDC ± 10%		
Power rating	22.8 W (12 VDC) 22.5 W (24 VDC)	29 W (12 VDC) 31 W (24 VDC)	32.6 W (12 VDC) 31 W (24 VDC)
Weight	0.18 kg (0.40 lb)	0.28 kg (0.64 lb)	0.44 kg (0.97 lb)

NOTE - For different conditions, please contact Walvoil Sales Dpt. - \*For coils further features see from page 206.

### Normally open configuration

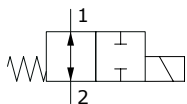

### Normally closed configuration

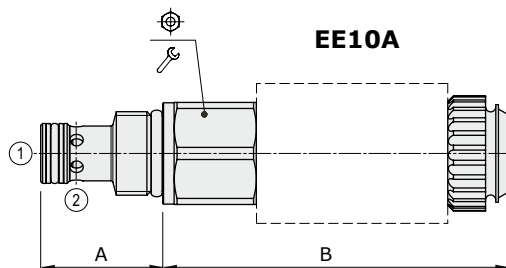
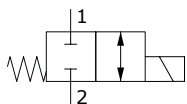

Valve type	A		B				Nm	lbft
	mm	in	mm	in				
EE08A/	10NB	27.6	1.09	76	2.99	24	30	22
	20NB	27.6	1.09	76	2.99	24	30	22
EE10A/	10PB	32.3	1.27	90.3	3.56	27	50	37
	20PB	32.3	1.27	90.3	3.56	27	50	37
EE12A/	10PB	46	1.81	102	4.02	32	80	59
	20PB	46	1.81	90.3	3.56	32	80	59

### Ordering codes and description composition

EE08A/10 NB

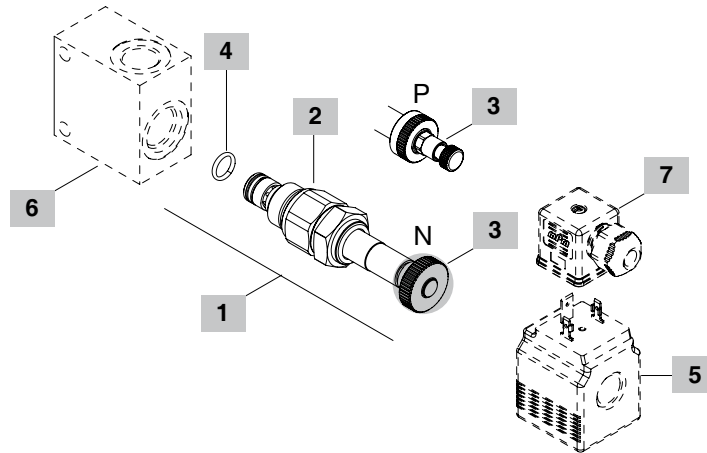
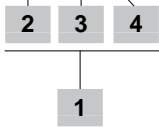

#### 1 Cartridges

TYPE	CODE	DESCRIPTION
<b>SAE cavity 08/2</b>		
<b>EE08A/10NB</b>	0EE08002001	Normally open configuration (N.O.) without emergency
<b>EE08A/20NB</b>	0EE08002000	Normally closed configuration (N.C.) without emergency
<b>SAE cavity 10/2</b>		
<b>EE10A/10PB</b>	0EE10002003	Normally open configuration (N.O.) with push-button emergency
<b>EE10A/20PB</b>	0EE10002002	Normally closed configuration (N.C.) with push-button emergency
<b>SAE cavity 12/2</b>		
<b>EE12A/10PB</b>	0EE12002005	Normally open configuration (N.O.) with push-button emergency
<b>EE12A/20PB</b>	0EE12002004	Normally closed configuration (N.C.) with push-button emergency

#### 2 Spool

TYPE	DESCRIPTION
<b>1</b>	Normally open configuration
<b>2</b>	Normally closed configuration

#### 3 Emergency

TYPE	DESCRIPTION
<b>N</b>	Without emergency only for 8/2
<b>P</b>	Push button type only for 10/2 and 12/2

Note: for configurations with different emergency contact Sales Dept.

#### 4 Seals

TYPE	DESCRIPTION
<b>B</b>	<b>NBR (Buna)</b> o-ring seals, std configuration
<b>V</b>	<b>FPM (Viton)</b> o-ring seals, contact Sales Dept.

#### 5 Coils

TYPE	CODE	DESCRIPTION
<b>BER 12 VDC</b>	4SLE001200	12VDC-ISO4400 coil for EE08A
<b>BIN 19 VDC</b>	4SL6000121	12VDC-ISO4400 coil for EE10A
<b>BIN 22 VDC</b>	4SL6000128	12VDC-ISO4400 coil for EE12A

For complete coils list see from page 206

#### 6 Valve body

TYPE	CODE	DESCRIPTION
<b>SAE 08/2-G 3/8</b>	3CC0820C11	Aluminium body for cavity 08 valve, G3/8 std thread
<b>SAE 10/2-G 3/8</b>	3CC1020C11	Aluminium body for cavity 08 valve, G3/8 std thread
<b>SAE 12/2-G 1/2</b>	3CC1220D11	Aluminium body for cavity 12 valve, G1/2 std thread

For steel bodies or different threading see from page 215

#### 7 Connector

TYPE	CODE	DESCRIPTION
<b>ISO4400</b>	4CN1009995	Connector

For complete connectors list see from page 206

**EE08A pressure drop vs. flow**  
 - Spool 1 -

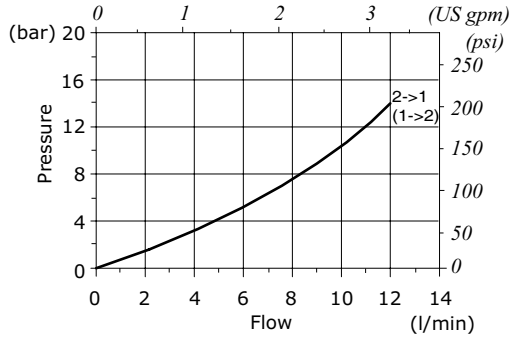

**EE08A pressure drop vs. flow**  
 - Spool 2 -

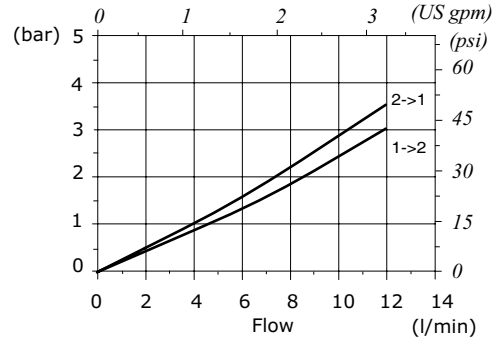

**EE10A pressure drop vs. flow**  
 - Spool 1 -

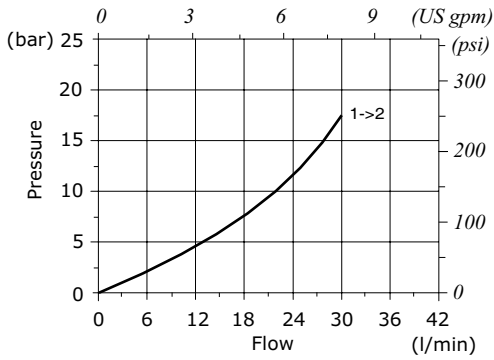

**EE10A pressure drop vs. flow**  
 - Spool 2 -

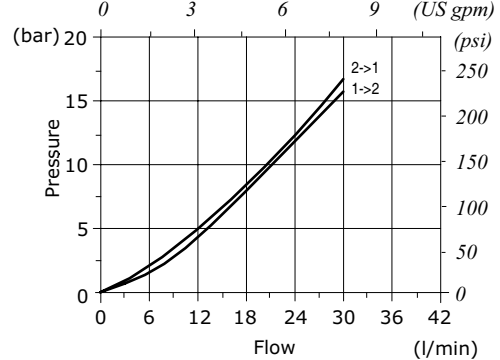

**EE12A pressure drop vs. flow**  
 - Spool 1 -

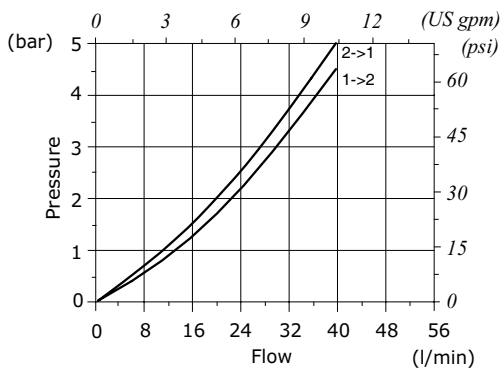

**EE12A pressure drop vs. flow**  
 - Spool 2 -

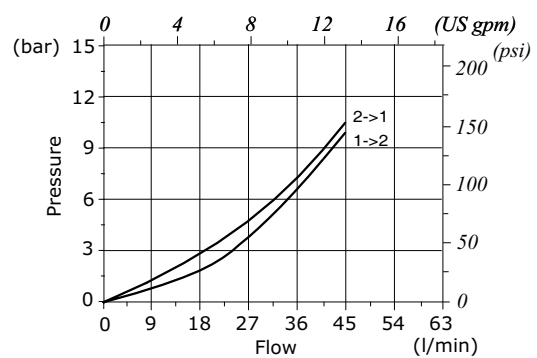







## EC..M type directional solenoid valves - 2 way / 2 positions

- Pilot operated
- Poppet type
- Oil leakage free from port 2 to port 1
- Normally open and closed configurations
- From SAE08 to SAE16 cavities

Technical specifications and diagrams are measured with mineral oil of 46 cSt viscosity at 40°C (104°F) temperature.

	<b>EC08M</b>	<b>EC10M</b>	<b>EC12M</b>	<b>EC16M</b>
Nominal flow	40 l/min (10.5 US gpm)	70 l/min (18.5 US gpm)	150 l/min (40 US gpm)	150 l/min (40 US gpm)
Max. pressure	380 bar (5500 psi)			
Oil leakage	at 210 bar (3050 psi)	0.25 cm <sup>3</sup> /min (0.015 in <sup>3</sup> /min)	0.25 cm <sup>3</sup> /min (0.015 in <sup>3</sup> /min)	0.25 cm <sup>3</sup> /min (0.015 in <sup>3</sup> /min)
Fluid	mineral based oil			
Viscosity	10-200 cSt			
Max level of contamination	18/16/13 ISO4406			
Fluid temperature	with NBR seals with FPM seals	from -20°C (-4°F) to 80°C (176°F) from -20°C (-4°F) to 100°C (212°F)		
Environmental temp. for working conditions	from -20°C (-4°F) to 50°C (122°F)			
Cavity	SAE 08/2	SAE 10/2	SAE 12/2	SAE 16/2
Coil type*	BER			
Nominal voltages	12 VDC - 24 VDC ± 10%			
Power rating	19.2 W (12 VDC - 24 VDC)			
Weight	0.135 kg (0.30 lb)	0.170 kg (0.37 lb)	0.230 kg (0.51 lb)	0.315 kg (0.69 lb)

NOTE - For different conditions, please contact Walvoil Sales Dpt. - \*For coils further features see from page 206.

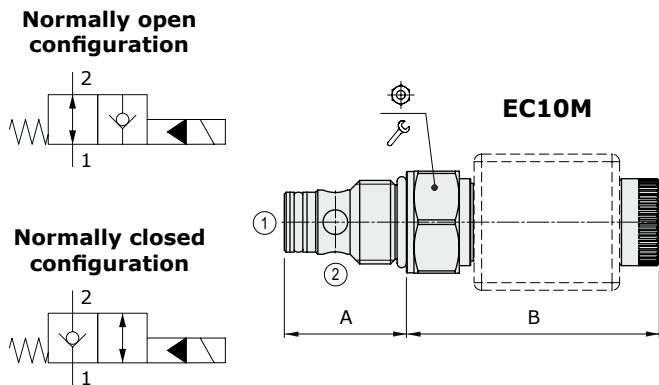

Valve type	A		B				Nm	lbft
	mm	in	mm	in				
EC08M/	10NB	28	1.10	67.2	2.64	24	30	22
	20NB	28	1.10	63.3	2.49	24	30	22
EC10M/	10NB	32.3	1.27	66.9	2.63	27	50	37
	20NB	32.3	1.27	63	2.48	27	50	37
EC12M/	10NB	45	1.77	61.1	2.40	32	80	59
	20NB	45	1.77	57.2	2.25	32	80	59
EC16M/	10NB	46	1.81	61.2	2.41	38	80	59
	20NB	46	1.81	57.3	2.26	38	80	59

For dimensions with different type of emergency see page 213

### Ordering codes and description composition

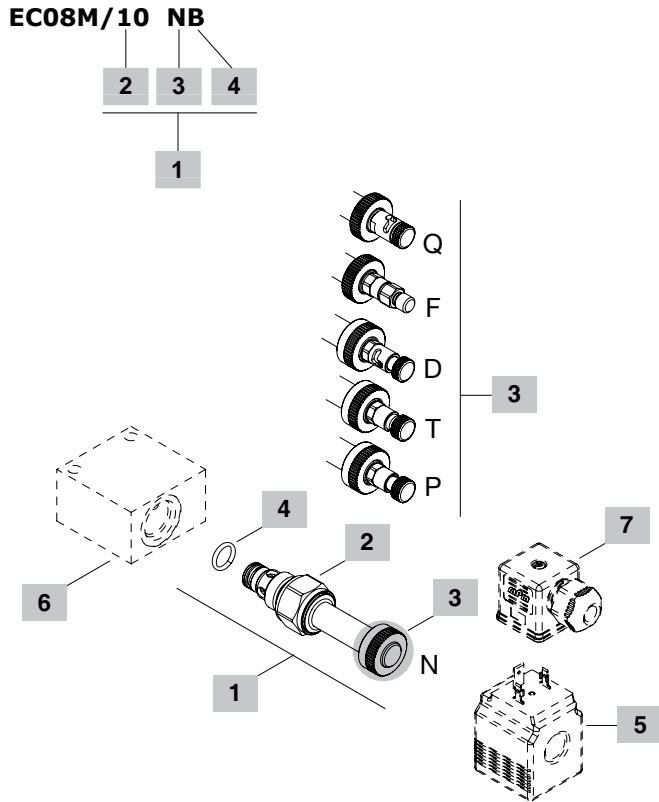

#### 1 Cartucce

TYPE	CODE	DESCRIPTION
<b>SAE cavity 08/2</b>		
<b>EC08M/10NB</b>	0EC08002031	Normally open (N.O.) without emergency
<b>EC08M/10PB</b>	0EC08002033	(N.O.) push button emergency
<b>EC08M/10TB</b>	0EC08002034	(N.O.) screw type emergency
<b>EC08M/10DB</b>	0EC08002035	(N.O.) push type with detent emergency
<b>EC08M/20NB</b>	0EC08002032	Normally closed (N.C.) without emergency
<b>EC08M/20FB</b>	0EC08002036	(N.C.) pull button emergency
<b>EC08M/20TB</b>	0EC08002037	(N.C.) screw type emergency
<b>EC08M/20QB</b>	0EC08002038	(N.C.) pull type with detent emergency
<b>SAE cavity 10/2</b>		
<b>EC10M/10NB</b>	0EC10002012	Normally open (N.O.) without emergency
<b>EC10M/10PB</b>	0EC10002014	(N.O.) push button emergency
<b>EC10M/10TB</b>	0EC10002015	(N.O.) screw type emergency
<b>EC10M/10DB</b>	0EC10002016	(N.O.) push type with detent emergency
<b>EC10M/20NB</b>	0EC10002013	Normally closed (N.C.) without emergency
<b>EC10M/20FB</b>	0EC10002017	(N.C.) pull button emergency
<b>EC10M/20TB</b>	0EC10002018	(N.C.) screw type emergency
<b>EC10M/20QB</b>	0EC10002019	(N.C.) pull type with detent emergency
<b>SAE cavity 12/2</b>		
<b>EC12M/10NB</b>	0EC12002007	Normally open (N.O.) without emergency
<b>EC12M/10PB</b>	0EC12002009	(N.O.) push button emergency
<b>EC12M/10TB</b>	0EC12002010	(N.O.) screw type emergency
<b>EC12M/10DB</b>	0EC12002011	(N.O.) push type with detent emergency
<b>EC12M/20NB</b>	0EC12002008	Normally closed (N.C.) without emergency
<b>EC12M/20FB</b>	0EC12002012	(N.C.) pull button emergency
<b>EC12M/20TB</b>	0EC12002013	(N.C.) screw type emergency
<b>EC12M/20QB</b>	0EC12002014	(N.C.) pull type with detent emergency
<b>SAE cavity 16/2</b>		
<b>EC16M/10NB</b>	0EC16002020	Normally open (N.O.) without emergency
<b>EC16M/10PB</b>	0EC16002022	(N.O.) push button emergency
<b>EC16M/10TB</b>	0EC16002023	(N.O.) screw type emergency
<b>EC16M/10DB</b>	0EC16002024	(N.O.) push type with detent emergency
<b>EC16M/20NB</b>	0EC16002021	Normally closed (N.C.) without emergency
<b>EC16M/20FB</b>	0EC16002025	(N.C.) pull button emergency
<b>EC16M/20TB</b>	0EC16002026	(N.C.) screw type emergency
<b>EC16M/20QB</b>	0EC16002027	(N.C.) pull type with detent emergency

#### 2 Spool

TYPE	DESCRIPTION
<b>1</b>	Normally open configuration
<b>2</b>	Normally closed configuration

#### 3 Emergency

TYPE	DESCRIPTION
<b>N</b>	Without emergency
<b>P</b>	Push button type (N.O.)
<b>T</b>	Screw type
<b>D</b>	Push type with detent (N.O.)
<b>F</b>	Pull button type (N.C.)
<b>Q</b>	Pull type with detent (N.C.)

#### 4 Seals

TYPE	DESCRIPTION
<b>B</b>	<b>NBR (Buna)</b> o-ring seals, std configuration
<b>V</b>	<b>FPM (Viton)</b> o-ring seals, contact Sales Dept

#### 5 Coil

TYPE	CODE	DESCRIPTION
<b>BER 12VDC</b>	4SLE001200	12VDC-ISO4400 coil

For complete coils list see from page 206

#### 6 Valve body

TYPE	CODE	DESCRIPTION
<b>SAE 08/2-G 3/8</b>	3CC0820C11	Aluminium body for cavity 08 valve, G3/8 std thread
<b>SAE 10/2-G 3/8</b>	3CC1020C11	Aluminium body for cavity 10 valve, G3/8 std thread
<b>SAE 12/2-G 1/2</b>	3CC1220D11	Aluminium body for cavity 12 valve, G1/2 std thread
<b>SAE 16/2-G 3/4</b>	3CC1620E11	Aluminium body for cavity 16 valve, G3/4 std thread

Note: aluminium body can stand up to 210 bar (3050 psi)  
For steel bodies or different threading see from page 215

#### 7 Connettere

TYPE	CODE	DESCRIPTION
<b>ISO4400</b>	4CN1009995	Connector

For complete connectors list see from page 206

# Directional control valves

Directional solenoid valves - 2 way / 2 positions

**EC..M type**

## Rating diagrams

**EC08M/10NB - EC08M/20N**  
pressure drop vs. flow

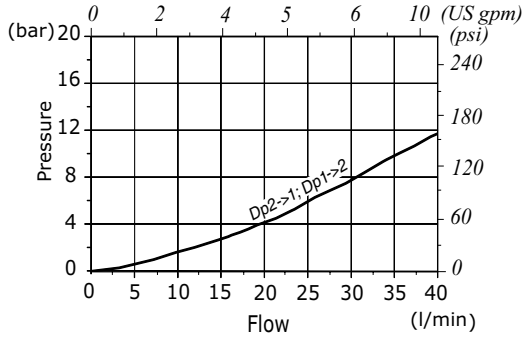

**EC10M/10NB - EC10M/20NB**  
pressure drop vs. flow

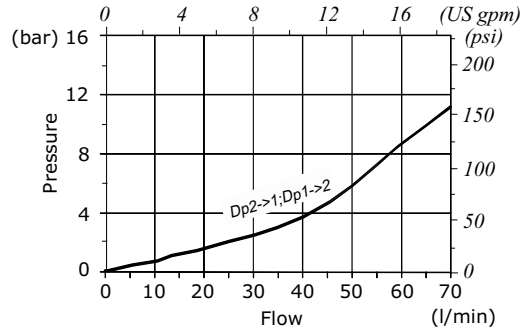

**EC12M/10NB - EC16M/10NB**  
pressure drop vs. flow

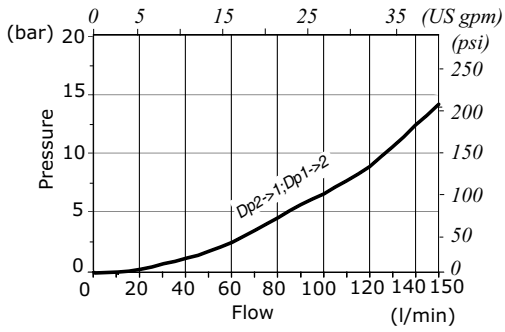

**EC12M/20NB - EC16M/20NB**  
pressure drop vs. flow

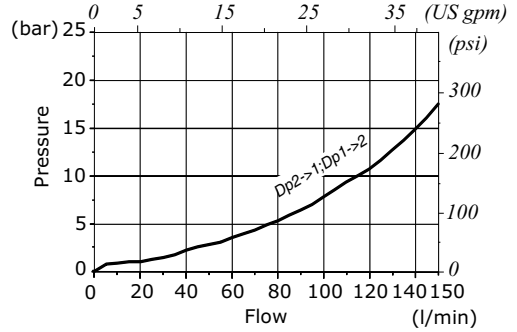





## EF..M type directional solenoid valves - 2 way / 2 positions

- Pilot operated
- Poppet type
- Oil leakage free from port 1 to port 2
- Normally open and closed configurations
- From SAE08 to SAE16 cavities

Technical specifications and diagrams are measured with mineral oil of 46 cSt viscosity at 40°C (104°F) temperature.

	EF08M	EF10M	EF12M	EF16M
Nominal flow	40 l/min (10.5 US gpm)	70 l/min (18.5 US gpm)	150 l/min (40 US gpm)	150 l/min (40 US gpm)
Max. pressure	380 bar (5500 psi)			
Oil leakage	at 210 bar (3050 psi)	0.50 cm <sup>3</sup> /min (0.030 in <sup>3</sup> /min)	0.50 cm <sup>3</sup> /min (0.030 in <sup>3</sup> /min)	0.50 cm <sup>3</sup> /min (0.030 in <sup>3</sup> /min)
Fluid	mineral based oil			
Viscosity	10-200 cSt			
Max level of contamination	18/16/13 ISO4406			
Fluid temperature	with NBR seals with FPM seals	from -20°C (-4°F) to 80°C (176°F) from -20°C (-4°F) to 100°C (212°F)		
Environmental temp. for working conditions	from -20°C (-4°F) to 50°C (122°F)			
Cavity	SAE 08/2	SAE 10/2	SAE 12/2	SAE 16/2
Coil type*	BER			
Nominal voltages	12 VDC - 24 VDC ± 10%			
Power rating	22.8 W (12 VDC) - 22.5 W (24 VDC)			
Weight	0.135 kg (0.30 lb)	0.170 kg (0.37 lb)	0.230 kg (0.51 lb)	0.315 kg (0.69 lb)

NOTE - For different conditions, please contact Walvoil Sales Dpt. - \*For coils further features see from page 206.

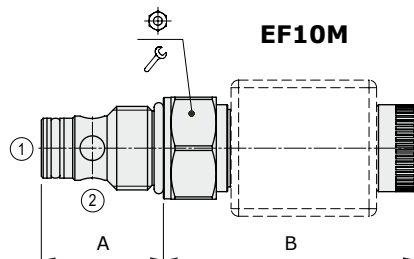
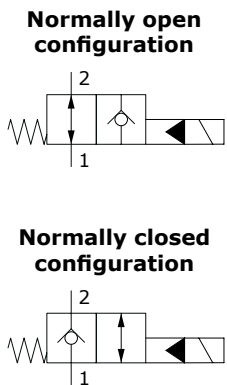

Valve type	A		B				Nm	lbft
	mm	in	mm	in				
EF08M/	10NB	28	1.10	67.2	2.64	24	30	22
	20NB	28	1.10	63.3	2.49	24	30	22
EF10M/	10NB	32.3	1.27	66.9	2.63	27	50	37
	20NB	32.3	1.27	63	2.48	27	50	37
EF12M/	10NB	45	1.77	61.1	2.40	32	80	59
	20NB	45	1.77	57.2	2.25	32	80	59
EF16M/	10NB	46	1.81	61.2	2.41	38	80	59
	20NB	46	1.81	57.3	2.26	38	80	59

For dimensions with different type of emergency see page 2131

### Ordering codes and description composition

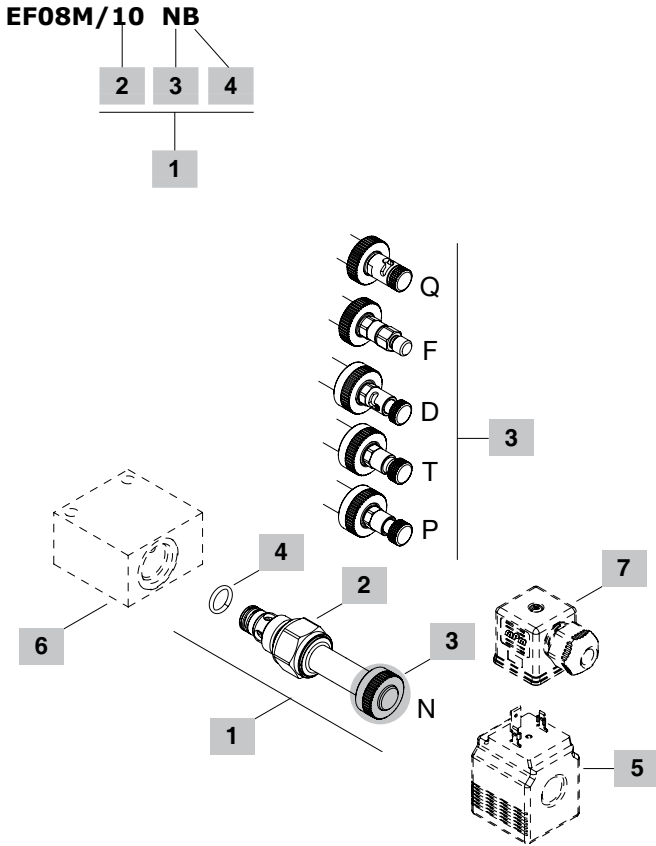

#### 1 Cartucce

TYPE	CODE	DESCRIPTION
<b>SAE cavity 08/2</b>		
<b>EF08M/10NB</b>	0EF08002000	Normally open (N.O.) without emergency
<b>EF08M/10PB</b>	0EF08002002	(N.O.) push button emergency
<b>EF08M/10TB</b>	0EF08002003	(N.O.) screw type emergency
<b>EF08M/10DB</b>	0EF08002004	(N.O.) push type with detent emergency
<b>EF08M/20NB</b>	0EF08002001	Normally closed (N.C.) without emergency
<b>EF08M/20FB</b>	0EF08002005	(N.C.) pull button emergency
<b>EF08M/20TB</b>	0EF08002006	(N.C.) screw type emergency
<b>EF08M/20QB</b>	0EF08002007	(N.C.) pull type with detent emergency

#### SAE cavity 10/2

<b>EF10M/10NB</b>	0EF10002000	Normally open (N.O.) without emergency
<b>EF10M/10PB</b>	0EF10002002	(N.O.) push button emergency
<b>EF10M/10TB</b>	0EF10002003	(N.O.) screw type emergency
<b>EF10M/10DB</b>	0EF10002004	(N.O.) push type with detent emergency
<b>EF10M/20NB</b>	0EF10002001	Normally closed (N.C.) without emergency
<b>EF10M/20FB</b>	0EF10002005	(N.C.) pull button emergency
<b>EF10M/20TB</b>	0EF10002006	(N.C.) screw type emergency
<b>EF10M/20QB</b>	0EF10002007	(N.C.) pull type with detent emergency

#### SAE cavity 12/2

<b>EF12M/10NB</b>	0EF12002000	Normally open (N.O.) without emergency
<b>EF12M/10PB</b>	0EF12002002	(N.O.) push button emergency
<b>EF12M/10TB</b>	0EF12002003	(N.O.) screw type emergency
<b>EF12M/10DB</b>	0EF12002004	(N.O.) push type with detent emergency
<b>EF12M/20NB</b>	0EF12002001	Normally closed (N.C.) without emergency
<b>EF12M/20FB</b>	0EF12002005	(N.C.) pull button emergency
<b>EF12M/20TB</b>	0EF12002006	(N.C.) screw type emergency
<b>EF12M/20QB</b>	0EF12002007	(N.C.) pull type with detent emergency

#### SAE cavity 16/2

<b>EF16M/10NB</b>	0EF16002000	Normally open (N.O.) without emergency
<b>EF16M/10PB</b>	0EF16002002	(N.O.) push button emergency
<b>EF16M/10TB</b>	0EF16002003	(N.O.) screw type emergency
<b>EF16M/10DB</b>	0EF16002004	(N.O.) push type with detent emergency
<b>EF16M/20NB</b>	0EF16002001	Normally closed (N.C.) without emergency
<b>EF16M/20FB</b>	0EF16002005	(N.C.) pull button emergency
<b>EF16M/20TB</b>	0EF16002006	(N.C.) screw type emergency
<b>EF16M/20QB</b>	0EF16002007	(N.C.) pull type with detent emergency

#### 2 Spool

TYPE	DESCRIPTION
<b>1</b>	Normally open configuration
<b>2</b>	Normally closed configuration

#### 3 Emergency

TYPE	DESCRIPTION
<b>N</b>	Without emergency
<b>P</b>	Push button type (N.O.)
<b>T</b>	Screw type
<b>D</b>	Push type with detent (N.O.)
<b>F</b>	Pull button type (N.C.)
<b>Q</b>	Pull type with detent (N.C.)

#### 4 Seals

TYPE	DESCRIPTION
<b>B</b>	<b>NBR (Buna)</b> o-ring seals, std configuration
<b>V</b>	<b>FPM (Viton)</b> o-ring seals, contact Sales Dept.

#### 5 Coils

TYPE	CODE	DESCRIPTION
<b>BER 12VDC</b>	4SLE001200	12VDC-ISO4400 coil

For complete coils list see from page 206

#### 6 Valve body

TYPE	CODE	DESCRIPTION
<b>SAE 08/2-G 3/8</b>	3CC0820C11	Aluminium body for cavity 08 valve, G 3/8 std thread
<b>SAE 10/2-G 3/8</b>	3CC1020C11	Aluminium body for cavity 10 valve, G 3/8 std thread
<b>SAE 12/2-G 1/2</b>	3CC1220D11	Aluminium body for cavity 12 valve, G 1/2 std thread
<b>SAE 16/2-G 3/4</b>	3CC1620E11	Aluminium body for cavity 16 valve, G 3/4 std thread

Note: aluminium body can stand up to 210 bar (3050 psi)  
For steel bodies or different threading see from page 215

#### 7 Connector

TYPE	CODE	DESCRIPTION
<b>ISO4400</b>	4CN1009995	Connector

For complete connectors list see from page 206

**Rating diagrams**

**EF08M/10NB - EF08M/20NB**  
 pressure drop vs. flow

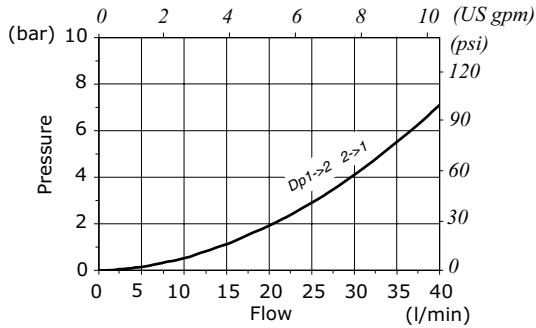

**EF10M/10NB - EF10M/20NB**  
 pressure drop vs. flow

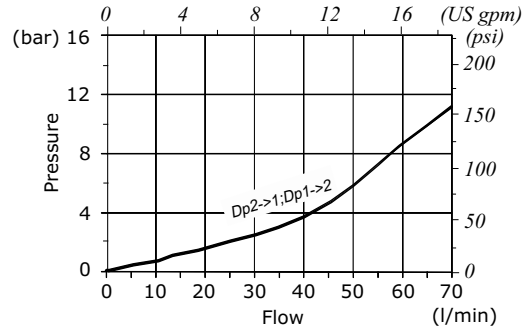

**EF12M/10NB - EF16M/10NB**  
 pressure drop vs. flow

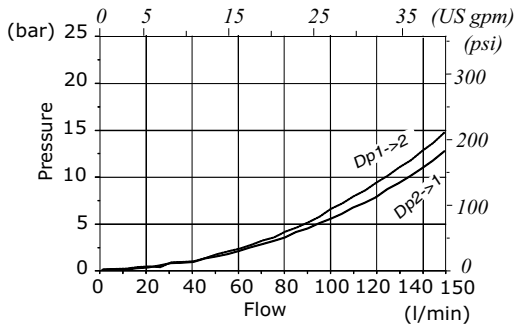

**EF12M/20NB - EF16M/20NB**  
 pressure drop vs. flow

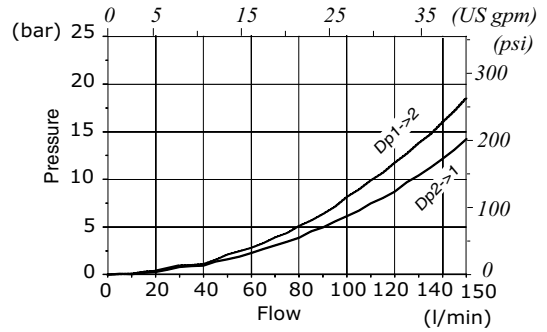







## EH..M type directional solenoid valves - 2 way / 2 positions

- Pilot operated
- Poppet type
- With check in both directions
- Normally open and closed configurations
- From SAE08 to SAE16 cavities

Technical specifications and diagrams are measured with mineral oil of 46 cSt viscosity at 40°C (104°F) temperature.

	<b>EH08M</b>	<b>EH10M</b>	<b>EH12M</b>	<b>EH16M</b>
Nominal flow	40 l/min (10.5 US gpm)	70 l/min (18.5 US gpm)	150 l/min (40 US gpm)	150 l/min (40 US gpm)
Max. pressure	380 bar (5500 psi)	380 bar (5500 psi)	350 bar (5100 psi)	380 bar (5500 psi)
Oil leakage	at 210 bar (3050 psi)	0.50 cm <sup>3</sup> /min (0.030 in <sup>3</sup> /min)	0.50 cm <sup>3</sup> /min (0.030 in <sup>3</sup> /min)	1 cm <sup>3</sup> /min (0.061 in <sup>3</sup> /min)
Fluid	mineral based oil			
Viscosity	10-200 cSt			
Max level of contamination	18/16/13 ISO4406			
Fluid temperature	with NBR seals with FPM seals	from -20°C (-4°F) to 80°C (176°F) from -20°C (-4°F) to 100°C (212°F)		
Environmental temp. for working conditions	from -20°C (-4°F) to 50°C (122°F)			
Cavity	SAE 08/2	SAE 10/2	SAE 12/2	SAE 16/2
Coil type*	BER			
Nominal voltages	12 VDC - 24 VDC ± 10%			
Power rating	22.8 W (12 VDC) - 22.5 W (24 VDC)			
Weight	0.135 kg (0.30 lb)	0.170 kg (0.37 lb)	0.230 kg (0.51 lb)	0.315 kg (0.69 lb)

NOTE - For different conditions, please contact Walvoil Sales Dpt. - \*For coils further features see from page 206.

### Normally open configuration

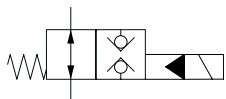

### Normally closed configuration

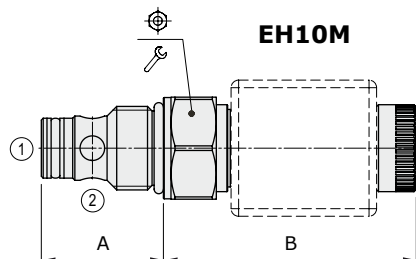
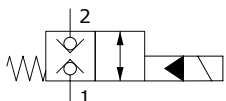

Valve type	A		B				Nm	lbft
	mm	in	mm	in				
EH08M/	10NB	28	1.10	67.2	2.64	24	30	22
	20NB	28	1.10	63.3	2.49	24	30	22
EH10M/	10NB	32.3	1.27	66.9	2.63	27	50	37
	20NB	32.3	1.27	63	2.48	27	50	37
EH12M/	10NB	45	1.77	61.1	2.40	32	80	59
	20NB	45	1.77	57.2	2.25	32	80	59
EH16M/	10NB	46	1.81	61.2	2.41	38	80	59
	20NB	46	1.81	57.3	2.26	38	80	59

For dimensions with different type of emergency see page 213

### Ordering codes and description composition

#### EH08M/10 NB

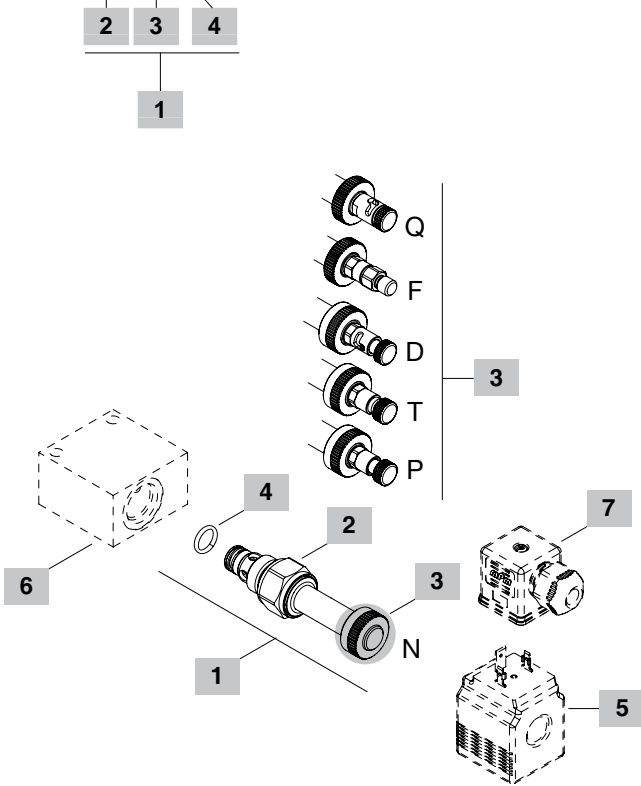

#### 1 Cartucce

TYPE	CODE	DESCRIPTION
<b>SAE cavity 08/2</b>		
<b>EH08M/10NB</b>	0EH08002000	Normally open (N.O.) without emergency
<b>EH08M/10PB</b>	0EH08002002	(N.O.) push button emergency
<b>EH08M/10TB</b>	0EH08002003	(N.O.) screw type emergency
<b>EH08M/10DB</b>	0EH08002004	(N.O.) push type with detent emergency
<b>EH08M/20NB</b>	0EH08002001	Normally closed (N.C.) without emergency
<b>EH08M/20FB</b>	0EH08002005	(N.C.) pull button emergency
<b>EH08M/20TB</b>	0EH08002006	(N.C.) screw type emergency
<b>EH08M/20QB</b>	0EH08002007	(N.C.) pull type with detent emergency
<b>SAE cavity 10/2</b>		
<b>EH10M/10NB</b>	0EH10002000	Normally open (N.O.) without emergency
<b>EH10M/10PB</b>	0EH10002002	(N.O.) push button emergency
<b>EH10M/10TB</b>	0EH10002003	(N.O.) screw type emergency
<b>EH10M/10DB</b>	0EH10002004	(N.O.) push type with detent emergency
<b>EH10M/20NB</b>	0EH10002001	Normally closed (N.C.) without emergency
<b>EH10M/20FB</b>	0EH10002005	(N.C.) pull button emergency
<b>EH10M/20TB</b>	0EH10002006	(N.C.) screw type emergency
<b>EH10M/20QB</b>	0EH10002007	(N.C.) pull type with detent emergency
<b>SAE cavity 12/2</b>		
<b>EH12M/10NB</b>	0EH12002000	Normally open (N.O.) without emergency
<b>EH12M/10PB</b>	0EH12002002	(N.O.) push button emergency
<b>EH12M/10TB</b>	0EH12002003	(N.O.) screw type emergency
<b>EH12M/10DB</b>	0EH12002004	(N.O.) push type with detent emergency
<b>EH12M/20NB</b>	0EH12002001	Normally closed (N.C.) without emergency
<b>EH12M/20FB</b>	0EH12002005	(N.C.) pull button emergency
<b>EH12M/20TB</b>	0EH12002006	(N.C.) screw type emergency
<b>EH12M/20QB</b>	0EH12002007	(N.C.) pull type with detent emergency
<b>SAE cavity 16/2</b>		
<b>EH16M/10NB</b>	0EH16002000	Normally open (N.O.) without emergency
<b>EH16M/10PB</b>	0EH16002002	(N.O.) push button emergency
<b>EH16M/10TB</b>	0EH16002003	(N.O.) screw type emergency
<b>EH16M/10DB</b>	0EH16002004	(N.O.) push type with detent emergency
<b>EH16M/20NB</b>	0EH16002001	Normally closed (N.C.) without emergency
<b>EH16M/20FB</b>	0EH16002005	(N.C.) pull button emergency
<b>EH16M/20TB</b>	0EH16002006	(N.C.) screw type emergency
<b>EH16M/20QB</b>	0EH16002007	(N.C.) pull type with detent emergency

#### 2 Spool

TYPE	DESCRIPTION
<b>1</b>	Normally open configuration
<b>2</b>	Normally closed configuration

#### 3 Emergency

TYPE	DESCRIPTION
<b>N</b>	Without emergency
<b>P</b>	Push button type (N.O.)
<b>T</b>	Screw type
<b>D</b>	Push type with detent (N.O.)
<b>F</b>	Pull button type (N.C.)
<b>Q</b>	Pull type with detent (N.C.)

#### 4 Seals

TYPE	DESCRIPTION
<b>B</b>	<b>NBR (Buna)</b> o-ring seals, std configuration
<b>V</b>	<b>FPM (Viton)</b> o-ring seals, contact Sales Dept.

#### 5 Coils

TYPE	CODE	DESCRIPTION
<b>BER 12VDC</b>	4SLE001200	12VDC-ISO4400 coil

For complete coils list see from page 206

#### 6 Valve body

TYPE	CODE	DESCRIPTION
<b>SAE 08/2-G 3/8</b>	3CC0820C11	Aluminium body for cavity 08 valve, G 3/8 std thread
<b>SAE 10/2-G 3/8</b>	3CC1020C11	Aluminium body for cavity 10 valve, G 3/8 std thread
<b>SAE 12/2-G 1/2</b>	3CC1220D11	Aluminium body for cavity 12 valve, G 1/2 std thread
<b>SAE 16/2-G 3/4</b>	3CC1620E11	Aluminium body for cavity 16 valve, G 3/4 std thread

Note: aluminium body can stand up to 210 bar (3050 psi)  
For steel bodies or different threading see from page 215

#### 7 Connector

TYPE	CODE	DESCRIPTION
<b>ISO4400</b>	4CN1009995	Connector

For complete connectors list see from page 206

# Directional control valves

Directional solenoid valves - 2 way / 2 positions

**EH..M type**

## Rating diagrams

**EH08M/10NB - EH08M/20NB**  
pressure drop vs. flow

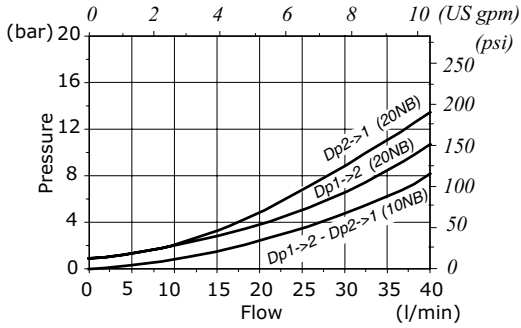

**EH10M/10NB - EH10M/20NB**  
pressure drop vs. flow

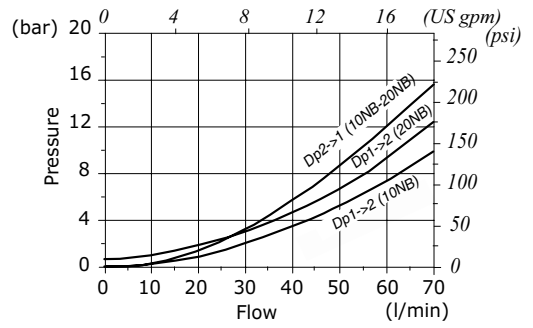

**EH12M/10NB - EH12M/20NB**  
pressure drop vs. flow

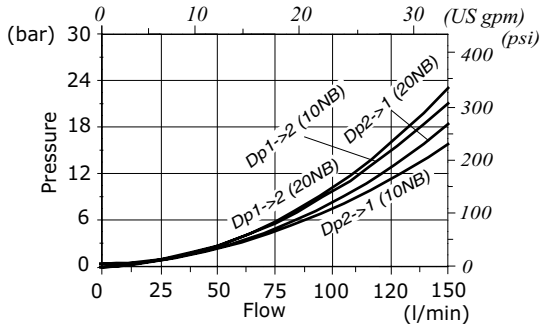

**EH16M/10NB - EH16M/20NB**  
pressure drop vs. flow

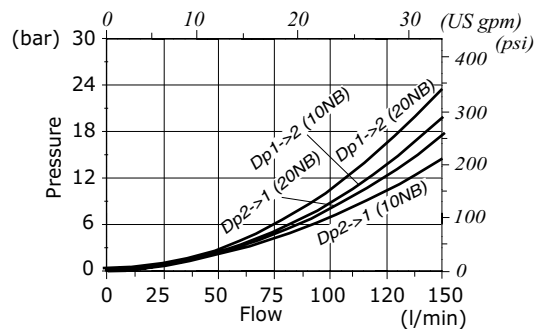





## EW... type directional solenoid valves - 2 way / 2 positions

- Direct acting
- Poppet type
- Normally open and closed configurations
- With check in both directions
- From SAE08 to SAE12 cavities

Technical specifications and diagrams are measured with mineral oil of 46 cSt viscosity at 40°C (104°F) temperature.

	EW08A	EW10A-EW10B	EW12B-EW12C
Nominal flow	10 l/min (2.64 US gpm)	25-30 l/min (6.6 - 7.9 US gpm)	50 l/min (13.2 US gpm)
Max. pressure	210 bar (3050 psi)		
Oil leakage	at 210 bar (3050 psi) 0.25 cm <sup>3</sup> /min (0.015 in <sup>3</sup> /min)	0.25 cm <sup>3</sup> /min (0.015 in <sup>3</sup> /min)	0.25 cm <sup>3</sup> /min (0.015 in <sup>3</sup> /min)
Fluid	mineral based oil		
Viscosity	10-200 cSt		
Max level of contamin.	18/16/13 ISO4406		
Fluid temperature	with NBR seals with FPM seals	from -20°C (-4°F) to 80°C (176°F) from -20°C (-4°F) to 100°C (212°F)	
Environmental temp. for working conditions	from -20°C (-4°F) to 50°C (122°F)		
Cavity	SAE 08/2	SAE 10/2	SAE 12/2
Coil type*	BT	BIN 19	BIN 22
Nominal voltages	12 VDC - 24 VDC ± 10%		
Power rating	21 W	29 W (12 VDC) - 31 W (24 VDC)	32.6 W (12 VDC) - 31 W (24 VDC)
Weight	0.16 kg (0.35 lb)	0.25 kg (0.55 lb)	0.44 kg (0.97 lb)

NOTE - For different conditions, please contact Walvoil Sales Dpt. - \*For coils further features see from page 206.

### Normally open configuration

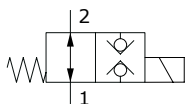

### Normally closed configuration

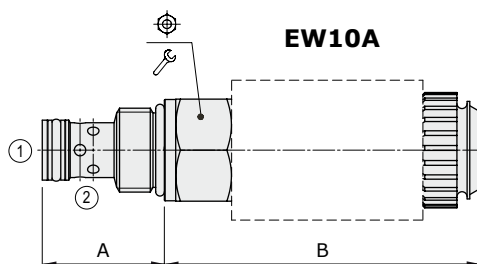
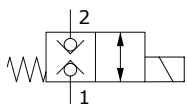

Valve type	A		B			
	mm	in	mm	in		
EW08A/10NB	28.5	1.12	65.7	2.59	24	30 22
EW08A/20NB	28.5	1.12	70.9	2.79	24	30 22
EW10A/20PB	32.3	1.27	83.3	3.28	27	50 37
EW10B/10NB	32.3	1.27	99.8	3.93	27	50 37
EW12C/20PB	46	1.81	98.7	3.89	32	80 59
EW12B/10NB	46	1.81	102.8	4.05	32	80 59

For dimensions with different type of emergency see page 213

### Ordering codes and description composition

#### EW08A/10 NB

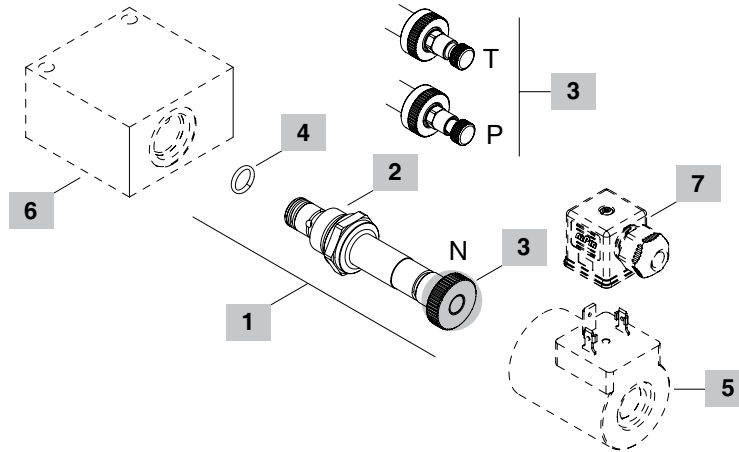
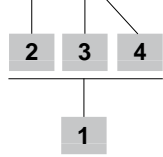

#### 1 Cartridges

TYPE	CODE	DESCRIPTION
<b>SAE cavity 08/2</b>		
<b>EW08A/10NB</b>	0EW08002001	Normally open configuration (N.O.) without emergency
<b>EW08A/10TB</b>	0EW08002003	Normally open configuration (N.O.) with screw type emergency
<b>EW08A/20NB</b>	0EW08002006	Normally closed configuration (N.C.) Without emergency
<b>EW08A/20PB</b>	0EW08002004	Normally closed configuration (N.C.) with push button emergency
<b>EW08A/20TB</b>	0EW08002002	Normally open configuration (N.C.) with screw type emergency
<b>SAE cavity 10/2</b>		
<b>EW10B/10NB</b>	0EW10002004	Normally open configuration (N.O.) without emergency
<b>EW10A/20PB</b>	0EW10002002	Normally closed configuration (N.C.) with push button emergency
<b>SAE cavity 12/2</b>		
<b>EW12B/10NB</b>	0EW12002005	Normally open configuration (N.O.) without emergency
<b>EW12C/20PB</b>	0EW12002003	Normally closed configuration (N.C.) with push button emergency

#### 2 Spool

TYPE	DESCRIPTION
<b>1</b>	Normally open configuration
<b>2</b>	Normally closed configuration

#### 3 Emergency

TYPE	DESCRIPTION
<b>N</b>	Without emergency
<b>T</b>	Screw type
<b>P</b>	Push button type (N.C.)

Note: emergency type depends on cavity type. See chapter 4 for availability.

#### 4 Seals

TYPE	DESCRIPTION
<b>B</b>	<b>NBR (Buna)</b> o-ring seals, std configuration
<b>V</b>	<b>FPM (Viton)</b> o-ring seals, contact Sales Dept.

#### 5 Coils

TYPE	CODE	DESCRIPTION
<b>BT 12VDC</b>	4SL3000120	12VDC-ISO4400 coil for EW08A
<b>BIN 19 VDC</b>	4SL6000121	12VDC-ISO4400 coil for EW10A-EW10B
<b>BIN 22 VDC</b>	4SL6000128	12VDC-ISO4400 coil for EW12A-EW12C

For complete coils list see from page 206

#### 6 Valve body

TYPE	CODE	DESCRIPTION
<b>SAE 08/2-G 3/8</b>	3CC0820C11	Aluminium body for cavity 08 valve, G3/8 std thread
<b>SAE 10/2-G 3/8</b>	3CC1020C11	Aluminium body for cavity 10 valve, G3/8 std thread
<b>SAE 12/2-G 1/2</b>	3CC1220D11	Aluminium body for cavity 12 valve, G1/2 std thread

For steel bodies or different threading see from page 215

#### 7 Connector

TYPE	CODE	DESCRIPTION
<b>ISO4400</b>	4CN1009995	Connector

For complete connectors list see from page 206

# Directional control valves

Directional solenoid valves - 2 way / 2 positions

**EW... type**

## Rating diagrams

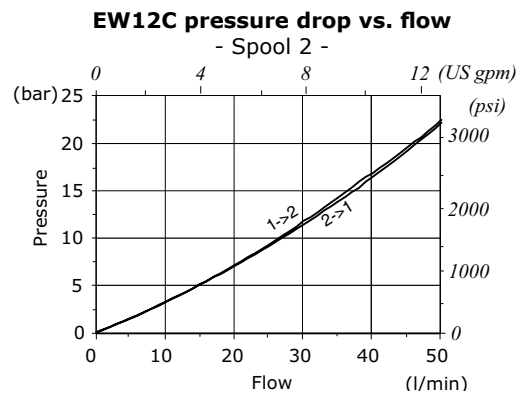
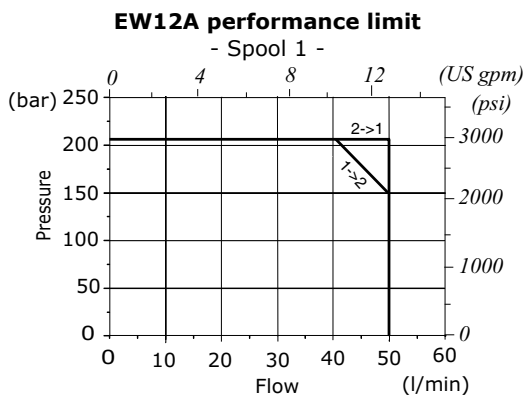
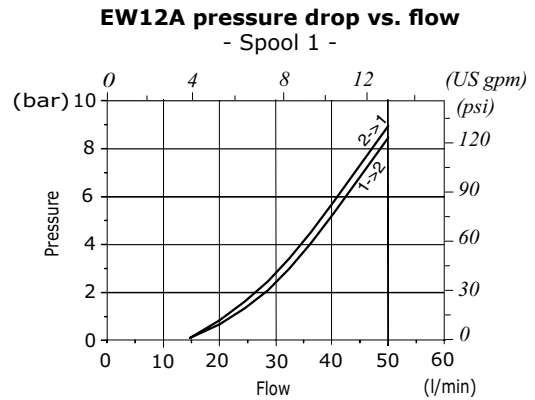
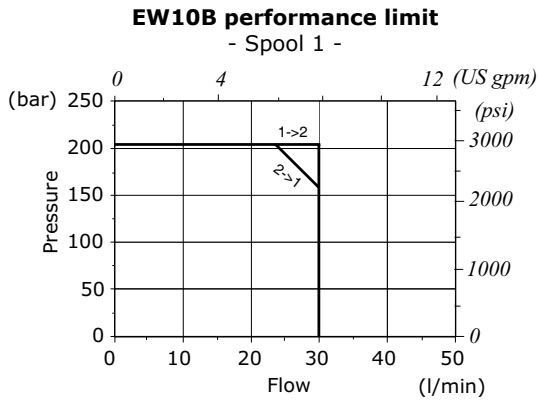
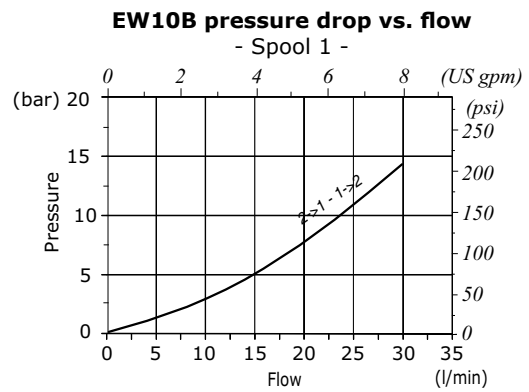
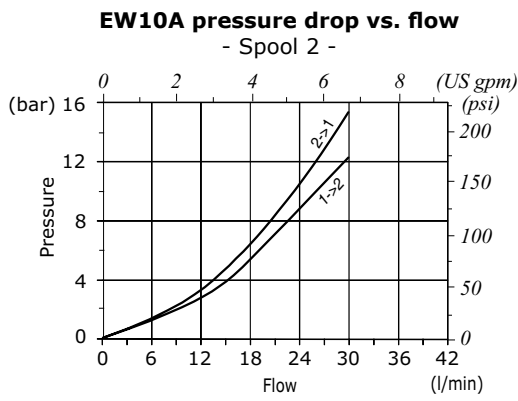
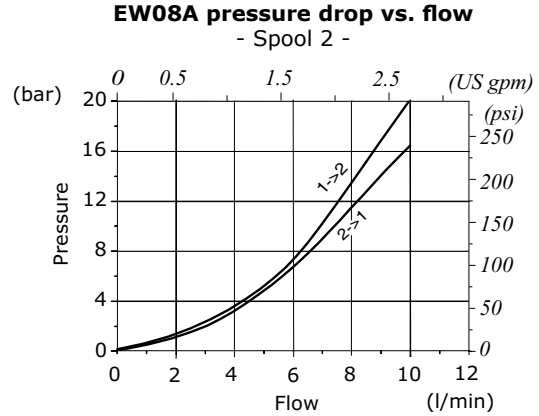
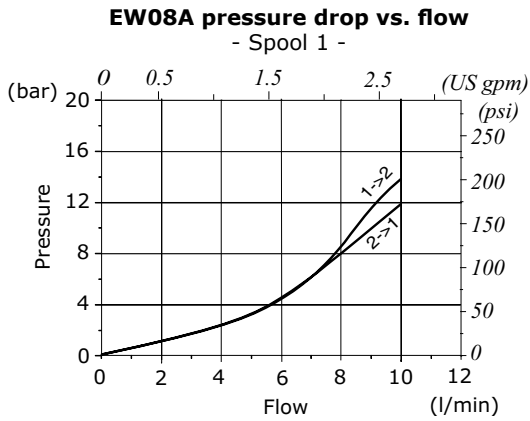







## EW..M type directional solenoid valves - 2 way / 2 positions

- Direct acting
- Poppet type
- Normally open and closed configurations
- With check in both directions
- From SAE08 to SAE10 cavities

Technical specifications and diagrams are measured with mineral oil of 46 cSt viscosity at 40°C (104°F) temperature.

	EW08M	EW10M
Nominal flow	20 l/min (5.28 US gpm)	40 l/min (10.6 US gpm)
Max. pressure	250 bar (3600 psi)	350 bar (5075 psi)
Oil leakage	at 210 bar (3050 psi) 0.25 cm <sup>3</sup> /min (0.015 in <sup>3</sup> /min)	0.25 cm <sup>3</sup> /min (0.015 in <sup>3</sup> /min)
Fluid	mineral based oil	
Viscosity	10-200 cSt	
Max level of contamination	18/16/13 ISO4406	
Fluid temperature	with NBR seals with FPM seals	from -20°C (-4°F) to 80°C (176°F) from -20°C (-4°F) to 100°C (212°F)
Environmental temp. for working conditions	from -20°C (-4°F) to 50°C (122°F)	
Cavity	SAE 08/2	SAE 10/2
Coil type*	BER	BH
Nominal voltages	12 VDC - 24 VDC ± 10%	
Power rating	22.8 W (12 VDC) - 22.5 W (24 VDC)	33 W
Weight	0.15 kg (0.33 lb)	0.30 kg (0.66 lb)

NOTE - For different conditions, please contact Walvoil Sales Dpt. - \*For coils further features see from page 206.

### Normally open configuration

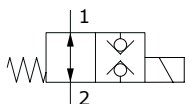

### Normally closed configuration

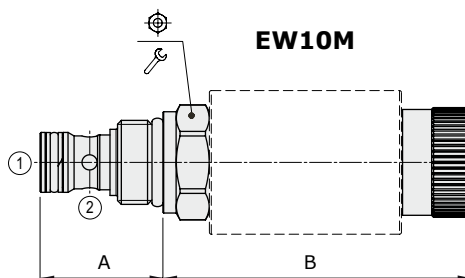
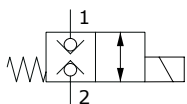

Valve type	A		B				Nm	lbft
	mm	in	mm	in				
EW08M/10NB	28	1.10	60.2	2.37	24	30	22	
EW08M/20NB	28	1.10	62.5	2.46	24	30	22	
EW10M/20NB	32.5	1.28	81.3	3.20	27	50	37	

For dimensions with different type of emergency see page 213

### Ordering codes and description composition

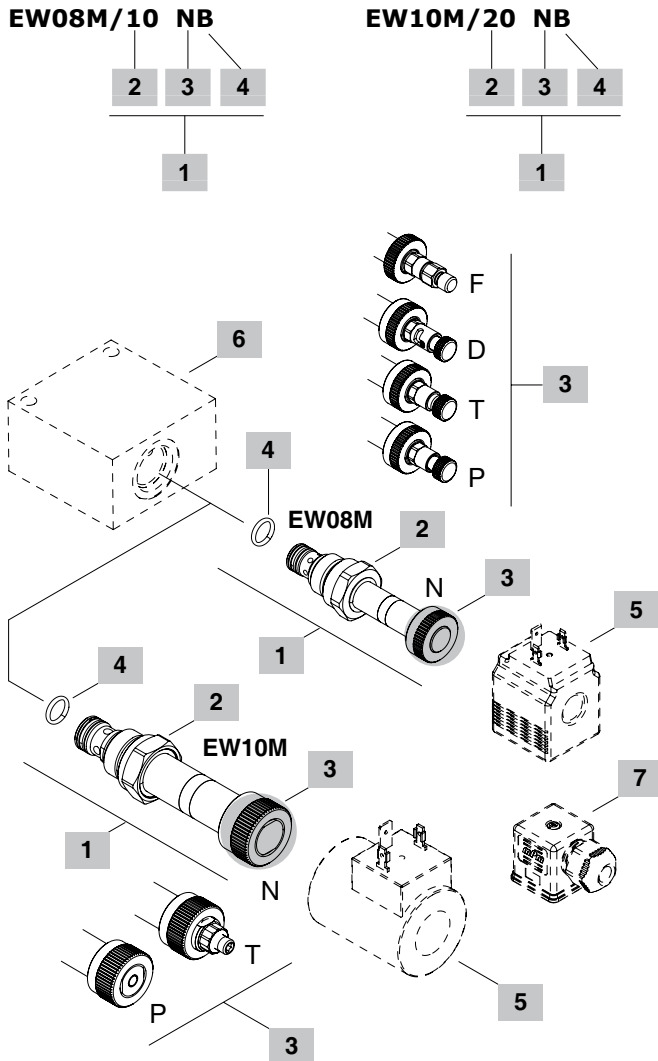

#### 1 Cartridges

TYPE	CODE	DESCRIPTION
<b>SAE cavity 08/2</b>		
<b>EW08M/10NB</b>	0EW08002014	Normally open (N.O.) without emergency
<b>EW08M/10FB</b>	0EW08002015	(N.O.) pull button emergency
<b>EW08M/10TB</b>	0EW08002016	(N.O.) screw type emergency
<b>EW08M/20NB</b>	0EW08002018	Normally closed (N.C.) without emergency
<b>EW08M/20PB</b>	0EW08002019	(N.C.) push button emergency
<b>EW08M/20TB</b>	0EW08002020	(N.C.) screw type emergency
<b>EW08M/20DB</b>	0EW08002021	(N.C.) push type with detent emergency
<b>SAE cavity 10/2</b>		
<b>EW10M/20NB</b>	0EW10002008	Normally closed (N.C.) without emergency
<b>EW10M/20TB</b>	0EW10002009	(N.C.) screw type emergency
<b>EW10M/20PB</b>	0EW10002010	(N.C.) push button emergency

#### 2 Spool

TIPO	DESCRIZIONE
<b>1</b>	Configurazione normalmente aperta
<b>2</b>	Configurazione normalmente chiusa

#### 3 Emergency

TYPE	DESCRIPTION
<b>N</b>	Without emergency
<b>P</b>	Push button type (N.C.)
<b>T</b>	Screw type (N.C. - N.O. for EW08M / N.C. for EW10M)
<b>D</b>	Push type with detent (N.C.)
<b>F</b>	Pull button type (N.O.)

#### 4 Seals

TYPE	DESCRIPTION
<b>B</b>	<b>NBR (Buna)</b> o-ring seals, std configuration
<b>V</b>	<b>FPM (Viton)</b> o-ring seals, contact Sales Dept.

#### 5 Coils

TYPE	CODE	DESCRIPTION
<b>BER 12VDC</b>	4SLE001200	12VDC-ISO4400 coil for EW08M
<b>BH 12VDC</b>	4SLD001200	12VDC-ISO4400 coil for EW10M

For complete coils list see from page 206

#### 6 Valve body

TYPE	CODE	DESCRIPTION
<b>SAE 08/2-G 3/8</b>	3CC0820C11	Aluminium body for cavity 08 valve, G3/8 std thread
<b>SAE 10/2-G 3/8</b>	3CC1020C11	Aluminium body for cavity 10 valve, G3/8 std thread

Note: aluminium body can stand up to 210 bar (3050 psi)  
For steel bodies or different threading see from page 215

#### 7 Connector

TYPE	CODE	DESCRIPTION
<b>ISO4400</b>	4CN1009995	Connector

For complete connectors list see from page 206

**Rating diagrams**

**EW08M pressure drop vs. flow**

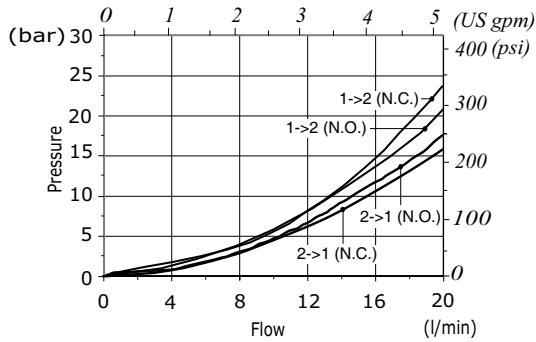

**EW10M pressure drop vs. flow (N.C.)**

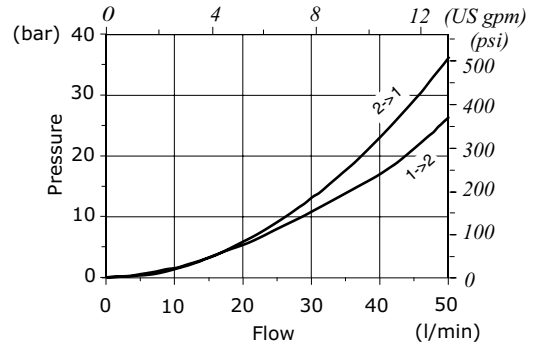

**EW08M performance limit (N.O.)**

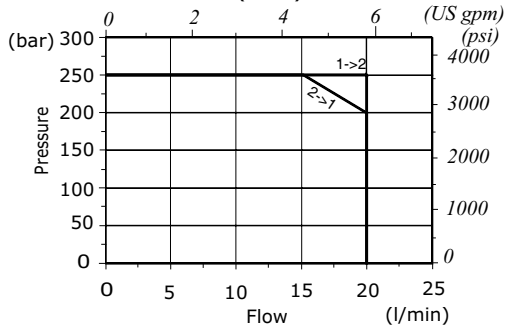

**EW08M performance limit (N.C.)**

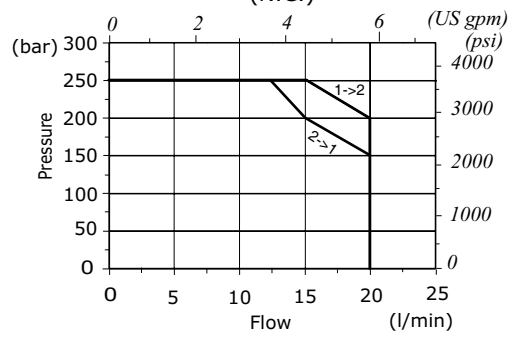

**EW10M performance limit (N.C.)**

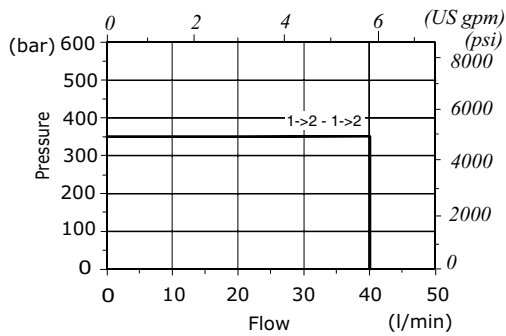





## EJ08F type directional solenoid valve - 3 way / 2 positions

- Direct acting
- Spool type
- Suitable for low pressure: 50 bar (725 psi)

Technical specifications and diagrams are measured with mineral oil of 46 cSt viscosity at 40°C (104°F) temperature.

### EJ08F

Nominal flow		12 l/min (3.17 US gpm)
Max. pressure		50 bar (725 psi)
Oil leakage	at 50 bar (725 psi)	5 cm <sup>3</sup> /min (0.30 in <sup>3</sup> /min)
Fluid		mineral based oil
Viscosity		10-200 cSt
Max level of contamination		18/16/13 ISO4406
Fluid temperature	with NBR seals with FPM seals	from -20°C (-4°F) to 80°C (176°F) from -20°C (-4°F) to 100°C (212°F)
Environmental temp. for working conditions		from -20°C (-4°F) to 50°C (122°F)
Cavity		SAE 08/3
Coil type*		BT
Nominal voltages		12 VDC - 24 VDC ± 10%
Power rating		21 W
Weight		0.175 kg (0.38 lb)

NOTE - For different conditions, please contact Walvoil Sales Dpt. - \*For coils further features see from page 206.

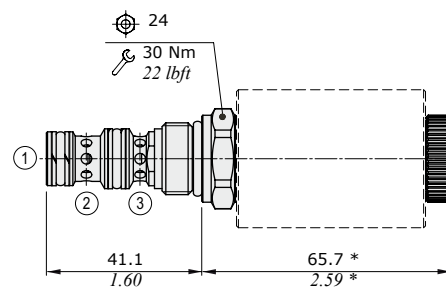
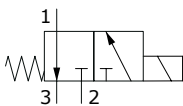

NOTE (\*): dimension for configuration **EJ08F/20NB**, for dimensions with different type of emergency see page 213.

### Ordering codes and description composition

EJ08F/20 NB

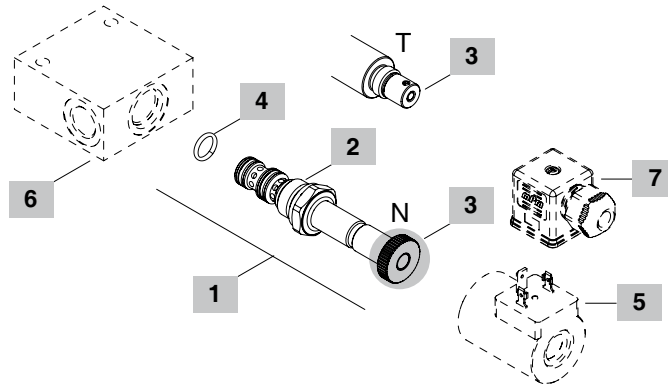
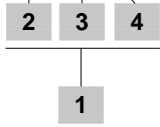

#### 1 Cartridges

TYPE	CODE	DESCRIPTION
<b>SAE cavity 08/3</b>		
<b>EJ08F/20NB</b>	0EJ08002029	Without emergency
<b>EJ08F/20TB</b>	0EJ08002043	Screw type emergency

#### 2 Spool

TYPE	DESCRIPTION
<b>2</b>	Spool 2

#### 3 Emergency

TYPE	DESCRIPTION
<b>N</b>	Without emergency
<b>T</b>	Screw type

#### 4 Seals

TYPE	DESCRIPTION
<b>B</b>	<b>NBR (Buna)</b> o-ring seals, std configuration
<b>V</b>	<b>FPM (Viton)</b> o-ring seals, contact Sales Dept.

#### 5 Coils

TYPE	CODE	DESCRIPTION
<b>BT 12VDC</b>	4SL3000120	12VDC-ISO4400 coil

For complete coils list see from page 206

#### 6 Valve body

TYPE	CODE	DESCRIPTION
<b>SAE 08/3-G 3/8</b>	3CC0830C11	Aluminium body for cavity 08 valve, G3/8 std thread

For steel bodies or different threading see from page 217

#### 7 Connector

TYPE	CODE	DESCRIPTION
<b>ISO4400</b>	4CN1009995	Connector

For complete connectors list see from page 206

### Rating diagrams

Pressure drop vs. flow

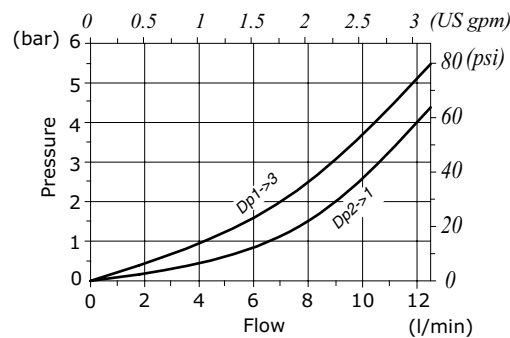



## EJ8CA type directional solenoid valve - 3 way / 2 positions

- Direct acting
- Spool type
- Suitable for low pressure: 70 bar (1015 psi)
- SAE 08/3C cavity

Technical specifications and diagrams are measured with mineral oil of 46 cSt viscosity at 40°C (104°F) temperature.

### EJ8CA

Nominal flow		10 l/min (2.64 US gpm)
Max. pressure		70 bar (1015 psi)
Oil leakage	at 70 bar (1015 psi)	20 cm <sup>3</sup> /min (1.22 in <sup>3</sup> /min)
Fluid		olio a base minerale
Viscosity		10-200 cSt
Max level of contamination		18/16/13 ISO4406
Fluid temperature	with NBR seals with FPM seals	from -20°C (-4°F) to 80°C (176°F) from -20°C (-4°F) to 100°C (212°F)
Environmental temp. for working conditions		from -20°C (-4°F) to 50°C (122°F)
Cavity		SAE 08/3C
Coil type <sup>(1)</sup>		BER
Nominal voltages		12 VDC - 24 VDC ± 10%
Power rating		22.8 W (12 VDC) - 22.5 W (24 VDC)
Weight		0.116 kg (0.26 lb)

NOTE - For different conditions, please contact Walvoil Sales Dpt. - <sup>(1)</sup> For coils further features see from page 206.

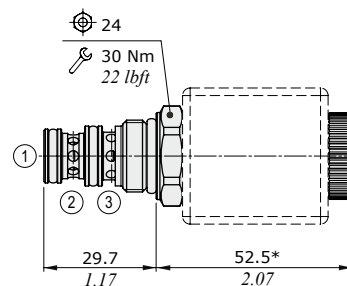
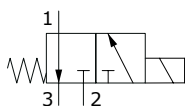

NOTE (\*): dimension for configuration **EJ8CA/20NB**, for dimensions with different type of emergency see page 213.

### Ordering codes and description composition

EJ8CA/20 NB

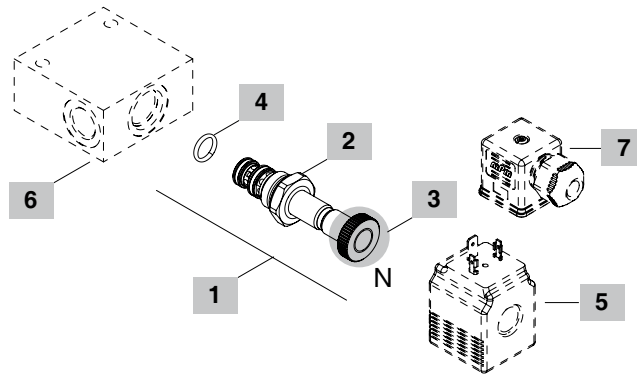
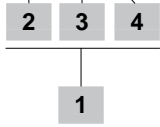

#### 1 Cartridges

TYPE	CODE	DESCRIPTION
<b>SAE cavity 08/3C</b>		
EJ8CA/20NB	0EJ8C002000	Without emergency

#### 2 Spool

TYPE	DESCRIPTION
2	Spool 2

#### 3 Emergency

TYPE	DESCRIPTION
N	Without emergency

#### 4 Seals

TYPE	DESCRIPTION
B	<b>NBR (Buna)</b> o-ring seals, std configuration
V	<b>FPM (Viton)</b> o-ring seals, contact Sales Dept.

#### 5 Coils

TYPE	CODE	DESCRIPTION
<b>BER 12VDC</b>		
4SLE001200		12VDC-ISO4400 coil

For complete coils list see from page 206

#### 6 Valve body

TYPE	CODE	DESCRIPTION
<b>SAE 08/3C-G 3/8</b>		
3CC0833C11		Aluminium body for cavity 08C valve, G3/8 std thread

For steel bodies or different threading see from page 217

#### 7 Connector

TYPE	CODE	DESCRIPTION
<b>ISO4400</b>		
4CN1009995		Connector

For complete connectors list see from page 206

### Rating diagrams

Pressure drop vs. flow

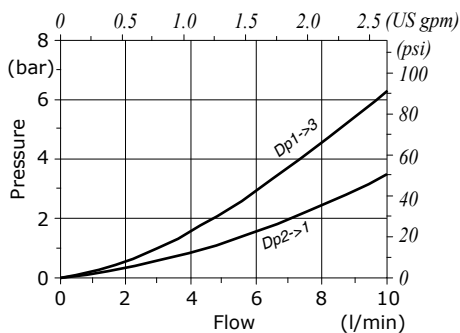

Performance limit

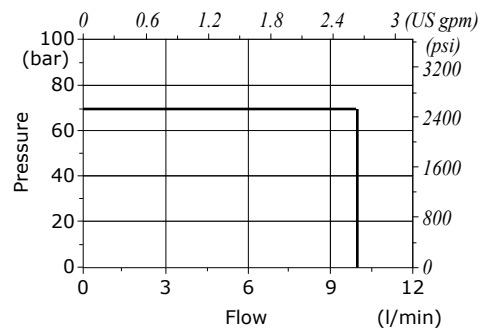





## EJ08G type directional solenoid valve - 3 way / 2 positions

- Direct acting
- Spool type
- Suitable for high pressure: 350 bar (5100 psi)

Technical specifications and diagrams are measured with mineral oil of 46 cSt viscosity at 40°C (104°F) temperature.

EJ08G		
Nominal flow		3 l/min (0.80 US gpm)
Max. pressure		350 bar (5100 psi)
Oil leakage	at 210 bar (3050 psi)	10 cm <sup>3</sup> /min (0.61 in <sup>3</sup> /min)
Fluid		mineral based oil
Viscosity		10-200 cSt
Max level of contamination		18/16/13 ISO4406
Fluid temperature	with NBR seals	from -20°C (-4°F) to 80°C (176°F)
	with FPM seals	from -20°C (-4°F) to 100°C (212°F)
Environmental temp. for working conditions		from -20°C (-4°F) to 50°C (122°F)
Cavity		SAE 08/3
Coil type*		BT
Nominal voltages		12 VDC - 24 VDC ± 10%
Power rating		21 W
Weight		0.134 kg (0.29 lb)

NOTE - For different conditions, please contact Walvoil Sales Dpt. - \*For coils further features see from page 206.

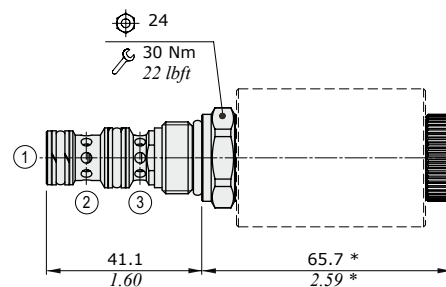
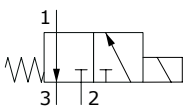

NOTE (\*): dimension for configuration **EJ08G/20NB**, for dimensions with different type of emergency see page 213.

### Ordering codes and description composition

#### EJ08G/20 NB

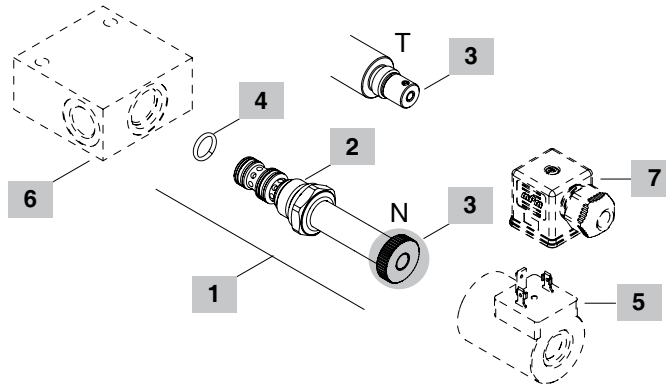
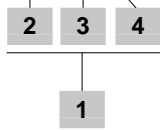

#### 1 Cartridges

TYPE	CODE	DESCRIPTION
<b>SAE cavity 08/3</b>		
<b>EJ08G/20NB</b>	0EJ08002035	Without emergency
<b>EJ08G/20TB</b>	0EJ08002042	Screw type emergency

#### 2 Spool

TYPE	DESCRIPTION
<b>2</b>	Spool 2

#### 3 Emergency

TYPE	DESCRIPTION
<b>N</b>	Without emergency
<b>T</b>	Screw type

#### 4 Seals

TYPE	DESCRIPTION
<b>B</b>	<b>NBR (Buna)</b> o-ring seals, std configuration
<b>V</b>	<b>FPM (Viton)</b> o-ring seals, contact Sales Dept.

#### 5 Coils

TYPE	CODE	DESCRIPTION
<b>BT 12VDC</b>	4SL3000120	12VDC-ISO4400 coil

For complete coils list see from page 206

#### 6 Valve body

TYPE	CODE	DESCRIPTION
<b>SAE 08/3-G 1/4</b>	3CC0830B11	Aluminium body for cavity 08 valve, G1/4 std thread

Note: aluminium body can stand up to 210 bar (3050 psi)  
For steel bodies or different threading see from page 217

#### 7 Connector

TYPE	CODE	DESCRIPTION
<b>ISO4400</b>	4CN1009995	Connector

For complete connectors list see from page 206

### Rating diagrams

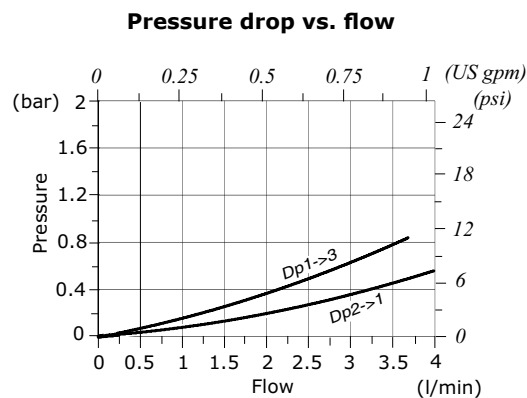



## EJ..M type directional solenoid valve - 3 way / 2 positions

- Direct acting
- Spool type
- From SAE08 to SAE10 cavities

Technical specifications and diagrams are measured with mineral oil of 46 cSt viscosity at 40°C (104°F) temperature.

	EJ08M	EJ10M
Nominal flow	25 l/min (6.6 US gpm)	40 l/min (10.5 US gpm)
Max. pressure	250 bar (3600 psi)	250 bar (3600 psi)
Oil leakage	at 210 bar (3050 psi) 40 cm <sup>3</sup> /min (2.44 in <sup>3</sup> /min)	80 cm <sup>3</sup> /min (4.88 in <sup>3</sup> /min)
Fluid	mineral based oil	
Viscosity	10-200 cSt	
Max level of contamination	18/16/13 ISO4406	
Fluid temperature	with NBR seals with FPM seals	from -20°C (-4°F) to 80°C (176°F) from -20°C (-4°F) to 100°C (212°F)
Environmental temp. for working conditions	from -20°C (-4°F) to 50°C (122°F)	
Cavity	SAE 08/3	SAE 10/3
Coils type*	BER	BC16
Nominal voltages	12 VDC - 24 VDC ± 10%	12 VDC - 24 VDC ± 10%
Power rating	22.8 W (12 VDC) - 22.5 W (24 VDC)	26.1 W (12 VDC) - 25.9 W (24 VDC)
Weight	0.125 kg (0.27 lb)	0.300 kg (0.661 lb)

NOTE - For different conditions, please contact Walvoil Sales Dpt. - \*For coils further features see from page 206.

**Spool 1**

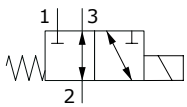

**Spool 2**

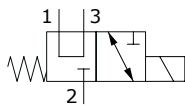

**Spool 3 (only EJ08M)**

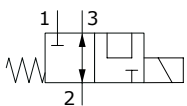

**Spool 4**

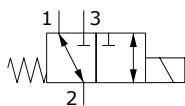

**Spool 5**

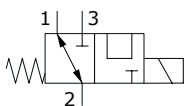

**Spool 6 (only EJ10M)**

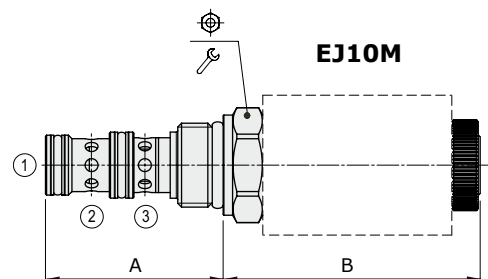
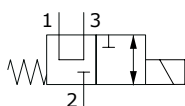

Valve type	A		B			
	mm	in	mm	in		
EJ08M/10NB	41.1	1.62	56.1	2.21	24	30
EJ10M/10NB	47	1.85	68	2.68	27	50

For dimensions with different type of emergency see page 213

### Ordering codes and description composition

EJ08M/10 NB

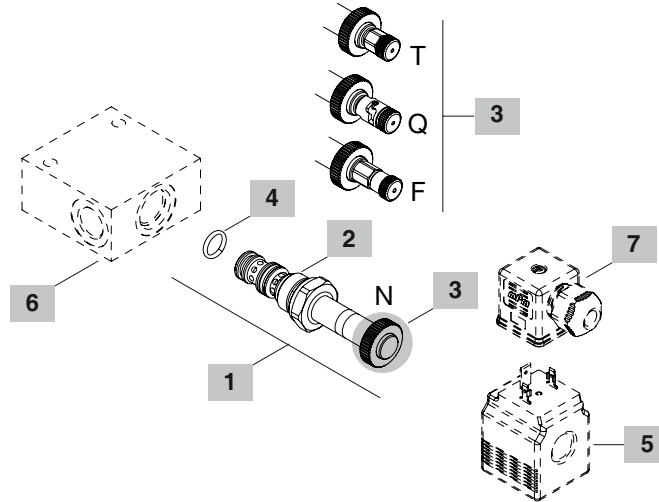
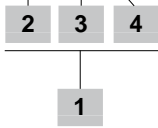

#### 1 Cartridges

TYPE	CODE	DESCRIPTION
<b>SAE cavity 08/3</b>		
EJ08M/10NB	0EJ08002030	Without emergency, spool 1
EJ08M/20NB	0EJ08002031	Without emergency, spool 2
EJ08M/30NB	0EJ08002032	Without emergency, spool 3
EJ08M/40NB	0EJ08002033	Without emergency, spool 4
EJ08M/50NB	0EJ08002034	Without emergency, spool 5
<b>SAE cavity 10/3</b>		
EJ10M/10NB	0EJ10002018	Without emergency, spool 1
EJ10M/20NB	0EJ10002019	Without emergency, spool 2
EJ10M/40NB	0EJ10002021	Without emergency, spool 4
EJ10M/50NB	0EJ10002022	Without emergency, spool 5
EJ10M/60NB	0EJ10002023	Without emergency, spool 6

#### 2 Spool

TYPE	DESCRIPTION
1	Spool 1
2	Spool 2
3	Spool 3
4	Spool 4
5	Spool 5
6	Spool 6

#### 3 Emergency

TYPE	DESCRIPTION
N	Without emergency
F	Pull button type
Q	Pull type with detent
T	Screw type

#### 4 Seals

TYPE	DESCRIPTION
B	<b>NBR (Buna)</b> o-ring seals, std configuration
V	<b>FPM (Viton)</b> o-ring seals, contact Sales Dept.

#### 5 Coils

TYPE	CODE	DESCRIPTION
<b>BER 12VDC</b>	4SLE001200	12VDC-ISO4400 coil for EJ08M
<b>BC 12VDC</b>	4SL8000120	12VDC-ISO4400 coil for EJ10M

For complete coils list see from page 206

#### 6 Valve body

TYPE	CODE	DESCRIPTION
<b>SAE 08/3-G 3/8</b>	3CC0830C11	Aluminium body for cavity 08 valve, G3/8 std thread
<b>SAE 10/3-G 3/8</b>	3CC1030C11	Aluminium body for cavity 10 valve, G3/8 std thread

Note: aluminium body can stand up to 210 bar (3050 psi)  
For steel bodies or different threading see from page 217

#### 7 Connector

TYPE	CODE	DESCRIPTION
<b>ISO4400</b>	4CN1009995	Connector

For complete connectors list see from page 206

**Rating diagrams**

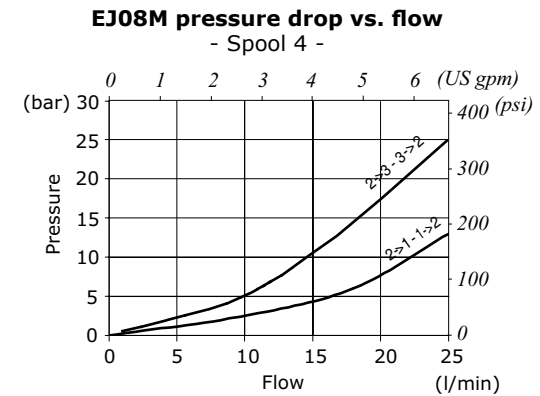
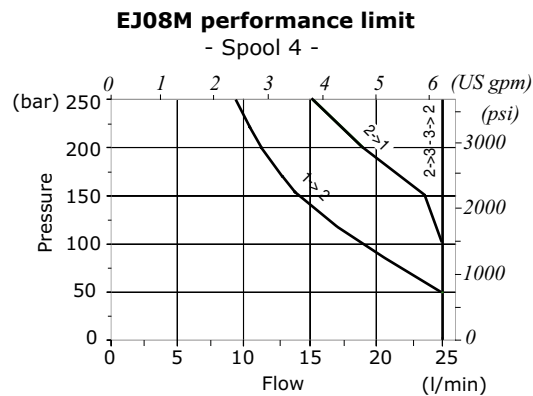
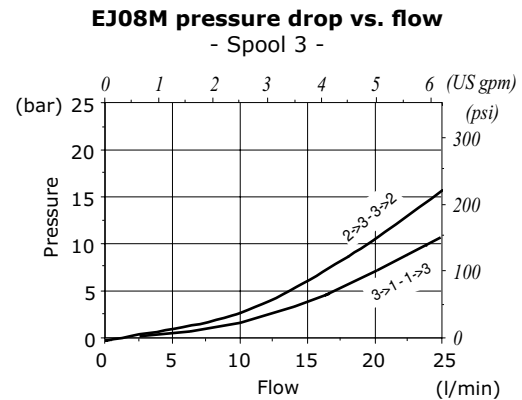
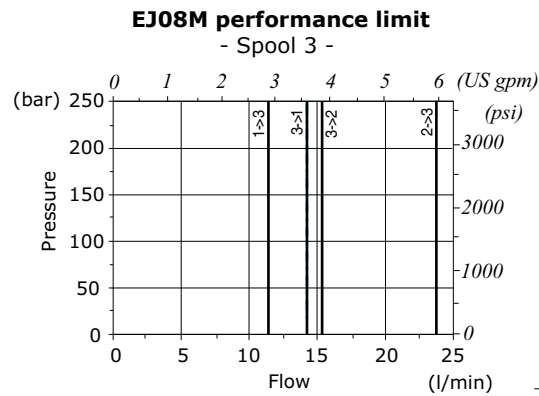
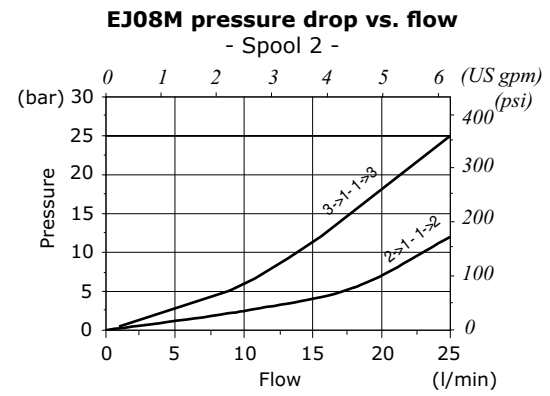
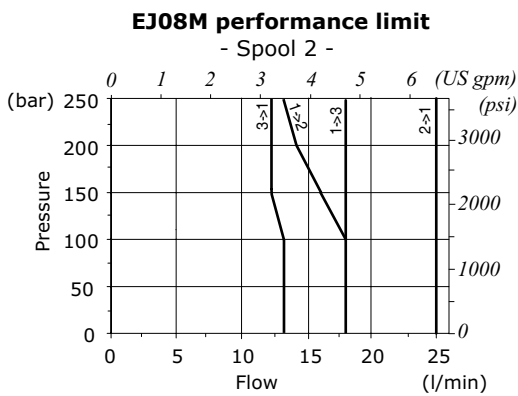
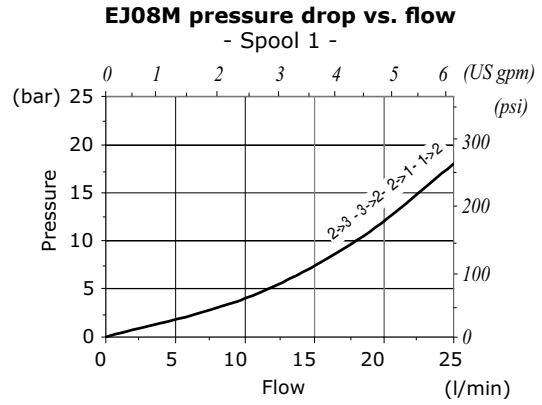
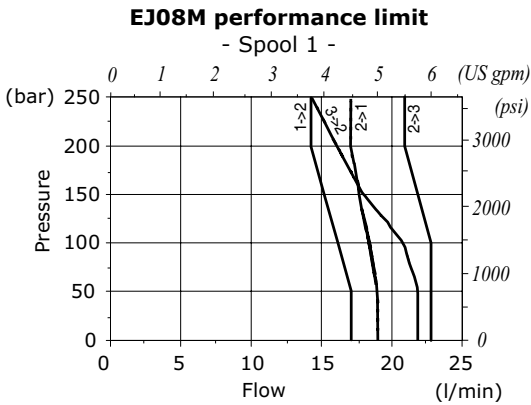

### Rating diagrams

**EJ08M performance limit**  
- Spool 5 -

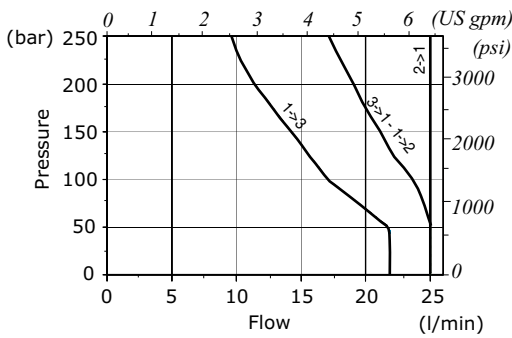

**EJ08M pressure drop vs. flow**  
- Spool 5 -

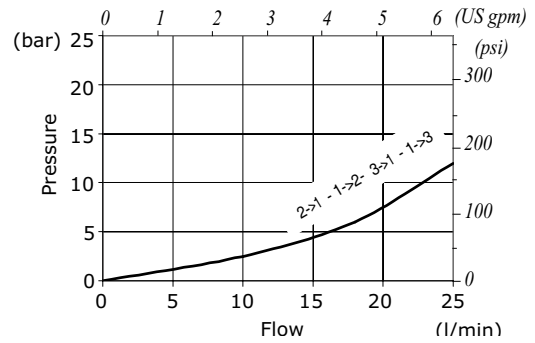

**EJ10M performance limit**  
- Spool 1 -

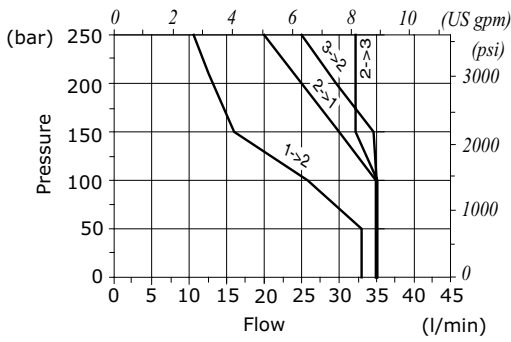

**EJ10Mp pressure drop vs. flow**  
- Spool 1 -

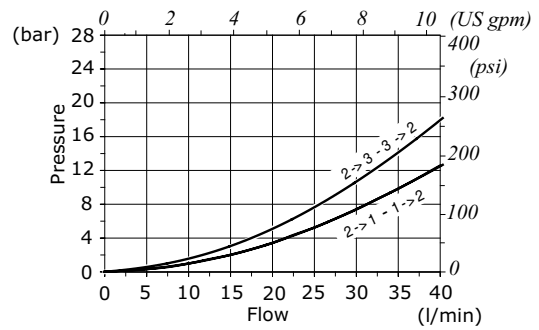

**EJ10M performance limit**  
- Spool 2 -

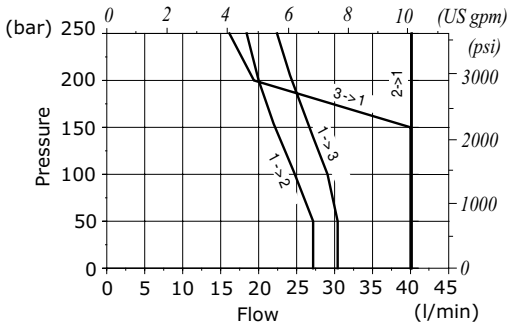

**EJ10M pressure drop vs. flow**  
- Spool 2 -

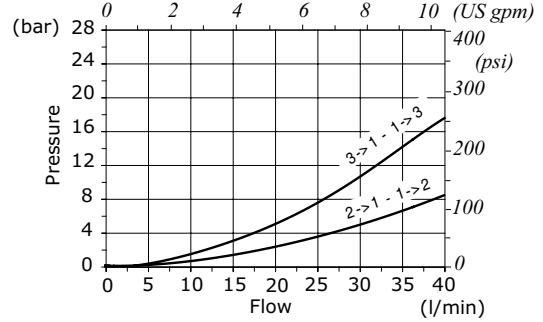

**EJ10M performance limit**  
- Spool 4 -

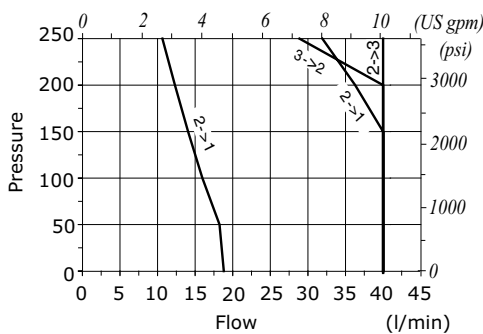

**EJ10M pressure drop vs. flow**  
- Spool 4 -

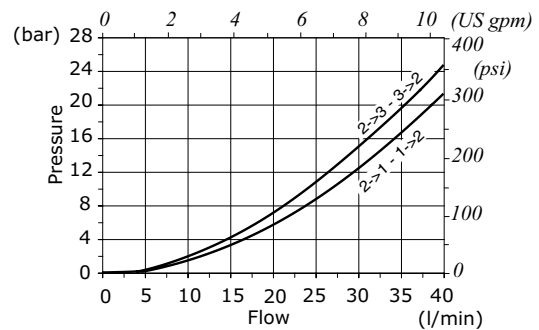

# Directional control valves

Directional solenoid valves - 3 way / 2 positions

**EJ..M type**

## Rating diagrams

**EJ10M performance limit**

- Spool 5 -

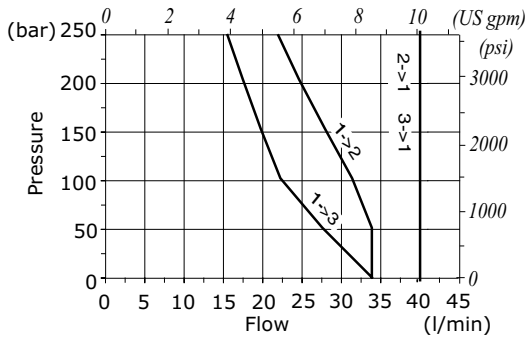

**EJ10M pressure drop vs. flow**

- Spool 5 -

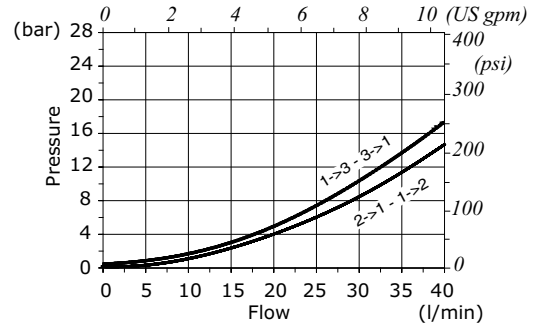

**EJ10M performance limit**

- Spool 6 -

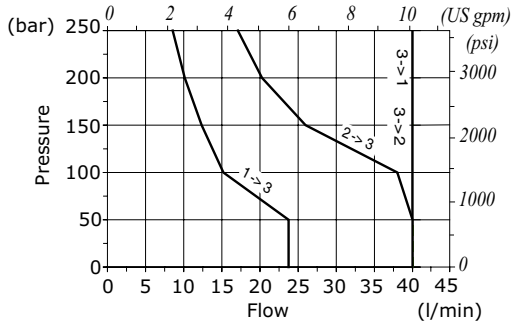

**EJ10M pressure drop vs. flow**

- Spool 6 -

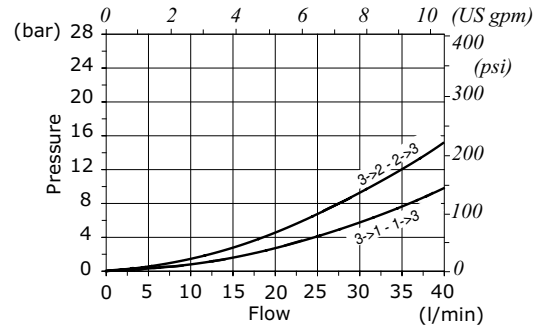







## EJ12A type directional solenoid valve - 3 way / 2 positions

- Direct acting
- Spool type

Technical specifications and diagrams are measured with mineral oil of 46 cSt viscosity at 40°C (104°F) temperature.

EJ12A		
Nominal flow		40 l/min (10.5 US gpm)
Max. pressure		210 bar (3050 psi)
Oil leakage	at 210 bar (3050 psi)	120 cm <sup>3</sup> /min (7.32 in <sup>3</sup> /min)
Fluid		mineral based oil
Viscosity		10-200 cSt
Max level of contamination		18/16/13 ISO4406
Fluid temperature	with NBR seals with FPM seals	from -20°C (-4°F) to 80°C (176°F) from -20°C (-4°F) to 100°C (212°F)
Environmental temp. for working conditions		from -20°C (-4°F) to 50°C (122°F)
Cavity		SAE 12/3
Coil type*		BIN 22
Nominal voltages		12 VDC - 24 VDC ± 10%
Power rating		32.6 W (12 VDC) - 31 W (24 VDC)
Weight		0.500 kg (1.10 lb)

NOTE - For different conditions, please contact Walvoil Sales Dpt. - \*For coils further features see from page 206.

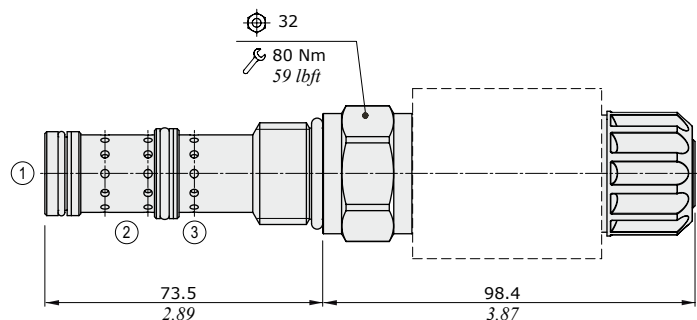
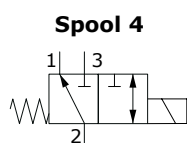
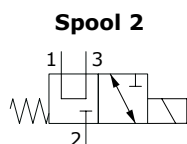
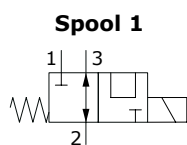

### Ordering codes and description composition

EJ12A/10 PB

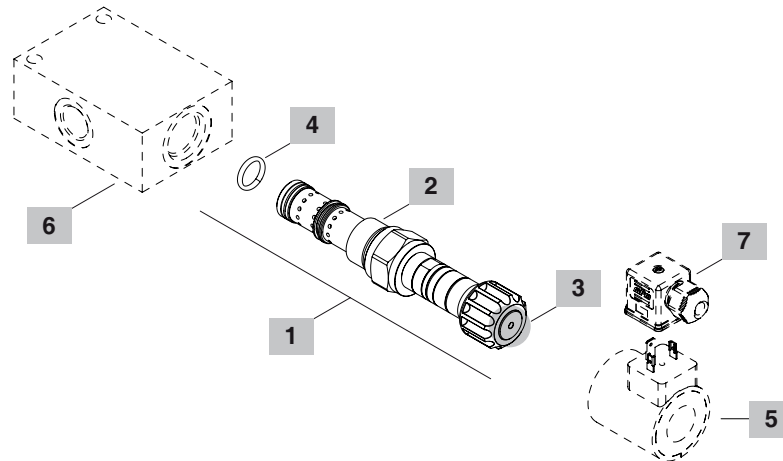
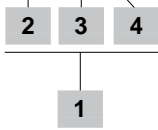

#### 1 Cartridges

TYPE	CODE	DESCRIPTION
<b>SAE cavity 12/3</b>		
EJ12A/10PB	0EJ12002005	Push button emergency, spool 1
EJ12A/20PB	0EJ12002006	Push button emergency, spool 2
EJ12A/40PB	0EJ12002008	Push button emergency, spool 4

#### 2 Spool

TYPE	DESCRIPTION
1	Spool 1
2	Spool 2
4	Spool 4

#### 3 Emergency

TYPE	DESCRIPTION
P	Push button type

#### 4 Seals

TYPE	DESCRIPTION
B	<b>NBR (Buna)</b> o-ring seals, std configuration
V	<b>FPM (Viton)</b> o-ring seals, contact Sales Dept.

#### 5 Coils

TYPE	CODE	DESCRIPTION
<b>BIN22 12VDC</b>	4SL6000128	12VDC-ISO4400 Coil

For complete coils list see from page 206

#### 6 Valve body

TYPE	CODE	DESCRIPTION
<b>SAE 12/3-G 1/2</b>	3CC1230D11	Aluminium body for cavity 12 valve, G1/2 std thread

For steel bodies or different threading see from page 217

#### 7 Connector

TYPE	CODE	DESCRIPTION
<b>ISO4400</b>	4CN1009995	Connector

For complete connectors list see from page 206

**Rating diagrams**

**Pressure drop vs. flow**  
 - Spool 1 -

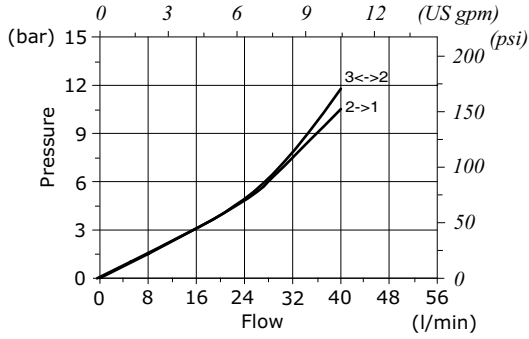

**Pressure drop vs. flow**  
 - Spool 2 -

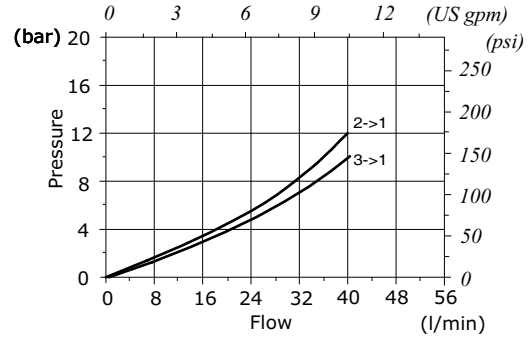

**Pressure drop vs. flow**  
 - Spool 4 -

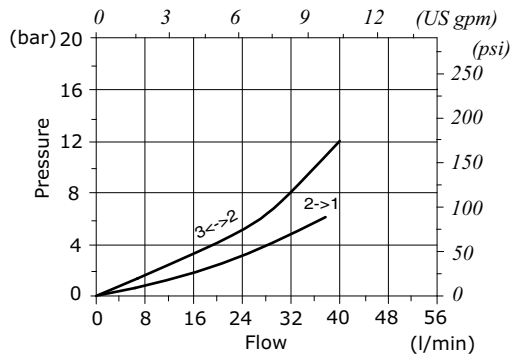

**Performance limit**  
 - Spool 4 -

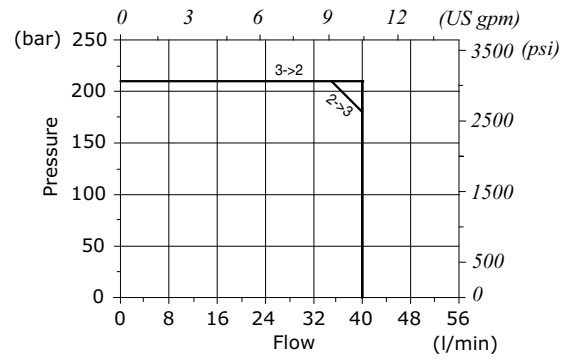





## EL... type directional solenoid valve - 3 way / 2 positions

- Direct acting
- Poppet type
- From SAE08 to SAE10 cavities

Technical specifications and diagrams are measured with mineral oil of 46 cSt viscosity at 40°C (104°F) temperature.

	EL08A	EL10C
Nominal flow	10 l/min (2.64 US gpm)	20 l/min (5.28 US gpm)
Max. pressure	210 bar (3050 psi)	
Oil leakage	at 210 bar (3050 psi) 0.25 cm <sup>3</sup> /min (0.015 in <sup>3</sup> /min)	
Fluid	mineral based oil	
Viscosity	10-200 cSt	
Max level of contamination	18/16/13 ISO4406	
Fluid temperature	with NBR seals with FPM seals	from -20°C (-4°F) to 80°C (176°F) from -20°C (-4°F) to 100°C (212°F)
Environmental temp. for working conditions	from -20°C (-4°F) to 50°C (122°F)	
Cavity	SAE 08/3	SAE 10/3
Coil type*	BC	BQ16
Nominal voltages	12 VDC - 24 VDC ± 10%	12 VDC ± 10%
Power rating	26.1 W (12 VDC) 25.9 W (24 VDC)	30 W
Weight	0.23 kg (0.50 lb)	0.27 kg (0.59 lb)

NOTE - For different conditions, please contact Walvoil Sales Dpt. - \*For coils further features see from page 206.

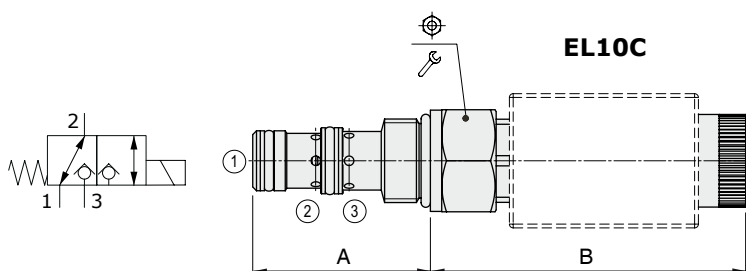

Valve type	A		B		⊕	⌘
	mm	in	mm	in		
EL08A/10NB	41,2	1.62	94.9	3.74	27	50 22
EL10C/10NB	46	1.81	86.7	3.41	27	50 37

For dimensions with different type of emergency see page 213

### Ordering codes and description composition

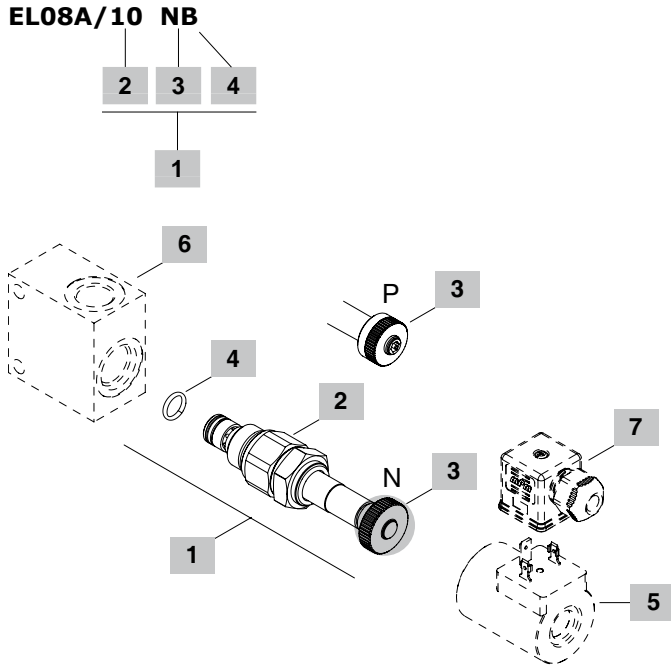

#### 1 Cartridges

TYPE	CODE	DESCRIPTION
<b>SAE cavity 08/3</b>		
<b>EL08A/10NB</b>	0EL08002001	Without emergency
<b>EL08A/10PB</b>	0EL08002000	With push-button emergency
<b>SAE cavity 10/3</b>		
<b>EL10C/10NB</b>	0EL10002008	Without emergency

#### 2 Spool

TYPE	DESCRIPTION
<b>1</b>	Spool 1

#### 3 Emergency

TYPE	DESCRIPTION
<b>N</b>	Without emergency
<b>P</b>	Push button type

Note: for 10/2 cavity only **N** type

#### 4 Seals

TYPE	DESCRIPTION
<b>B</b>	<b>NBR (Buna)</b> o-ring seals, std configuration
<b>V</b>	<b>FPM (Viton)</b> o-ring seals, contact Sales Dept.

#### 5 Coils

TYPE	CODE	DESCRIPTION
<b>BC 12 VDC</b>	4SL8000120	12VDC-ISO4400 coil for EL08A
<b>BQ16 12VDC</b>	4SL8000121	12VDC-ISO4400 coil for EL10C

For complete coils list see from page 206

#### 6 Valve body

TYPE	CODE	DESCRIPTION
<b>SAE 08/3-G 1/4</b>	3CC0830B11	Aluminium body for cavity 08 valve, G 1/4 std thread
<b>SAE 10/3-G 3/8</b>	3CC1030C11	Aluminium body for cavity 10 valve, G 3/8 std thread

For steel bodies or different threading see from page 217

#### 7 Connector

TYPE	CODE	DESCRIPTION
<b>ISO4400</b>	4CN1009995	Connector

For complete connectors list see from page 206

### Rating diagrams

Pressure drop vs. flow EL08A

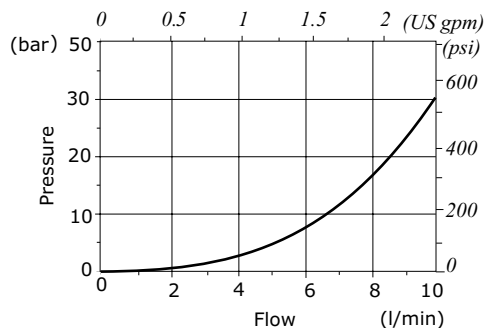

Pressure drop vs. flow EL10C

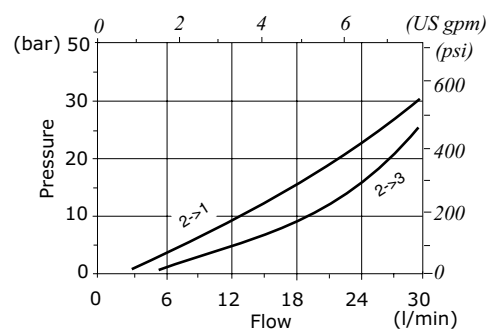



## EL08B type directional solenoid valve - 3 way / 2 positions

- Direct acting
- Poppet type
- SAE08 cavity
- Low power consumption

Technical specifications and diagrams are measured with mineral oil of 46 cSt viscosity at 40°C (104°F) temperature.

### EL08B

Nominal flow		10 l/min (2.64 US gpm)
Max. pressure		250 bar (3600 psi)
Oil leakage	at 210 bar (3050 psi)	0.25 cm <sup>3</sup> /min (0.015 in <sup>3</sup> /min)
Fluid		mineral based oil
Viscosity		10-200 cSt
Max level of contamination		18/16/13 ISO4406
Fluid temperature	with NBR seals with FPM seals	from -20°C (-4°F) to 80°C (176°F) from -20°C (-4°F) to 100°C (212°F)
Environmental temp. for working conditions		from -20°C (-4°F) to 50°C (122°F)
Cavity		SAE 08/3
Coil type*		BER
Nominal voltages		12 VDC - 24 VDC ± 10%
Power rating		19 W
Weight		0.16 kg (0.35 lb)

NOTE - For different conditions, please contact Walvoil Sales Dpt. - \*For coils further features see from page 206.

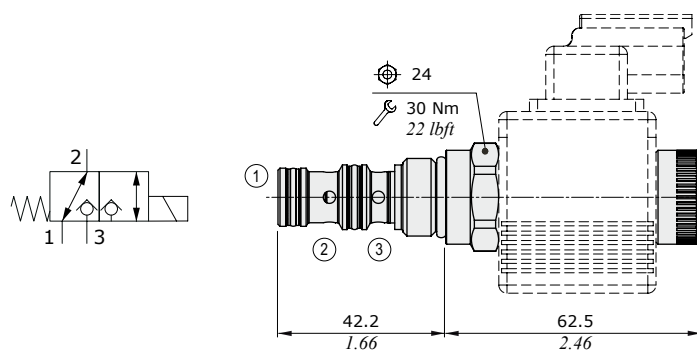

### Ordering codes and description composition

#### EL08B/10 NB

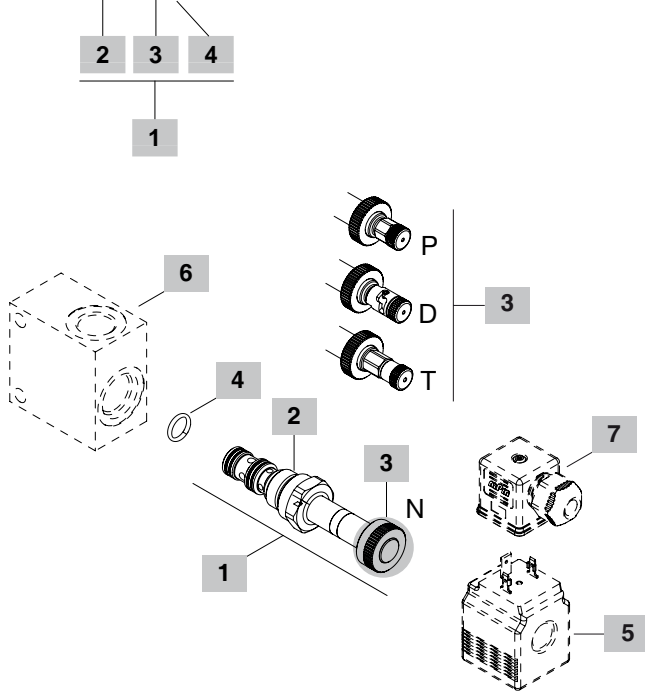

#### 1 Cartridges

TYPE	CODE	DESCRIPTION
<b>EL08B/10NB</b>	0EL08002009	Without emergency
<b>EL08B/10PB</b>	0EL08002006	With push-button emergency
<b>EL08B/10TB</b>	0EL08002007	Screw type emergency
<b>EL08B/10DB</b>	0EL08002008	Push type with detent emergency

#### 2 Spool

TYPE	DESCRIPTION
<b>1</b>	Spool 1

#### 3 Emergency

TYPE	DESCRIPTION
<b>N</b>	Without emergency
<b>P</b>	Push-button emergency
<b>T</b>	Screw type emergency
<b>D</b>	Push type with detent emergency

#### 4 Seals

TYPE	DESCRIPTION
<b>B</b>	<b>NBR (Buna)</b> o-ring seals, std configuration
<b>V</b>	<b>FPM (Viton)</b> o-ring seals, contact Sales Dept.

#### 5 Coil

TYPE	CODE	DESCRIPTION
<b>BER 12 VDC</b>	4SLE001200A	Bobina 12VDC-ISO4400

For complete coils list see from page 206

#### 6 Valve body

TYPE	CODE	DESCRIPTION
<b>SAE 08/3-G 1/4</b>	3CC0830B11	Aluminium body for cavity 08 valve, G 1/4 std thread

For steel bodies or different threading see from page 217

#### 7 Connector

TYPE	CODE	DESCRIPTION
<b>ISO4400</b>	4CN1009995	Connector

For complete connectors list see from page 206

### Rating diagrams

Pressure drop vs. flow

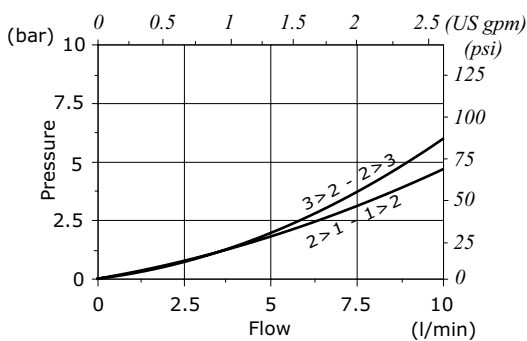

Performance limit

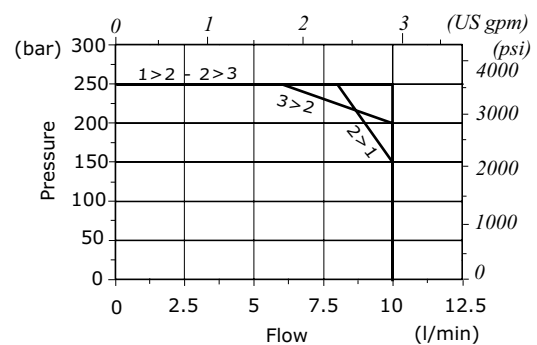





## ER..M type directional solenoid valve - 4 way / 2 positions

- Direct acting
- Spool type
- From SAE08 to SAE12 cavities

Technical specifications and diagrams are measured with mineral oil of 46 cSt viscosity at 40°C (104°F) temperature.

	ER08M	ER10M	ER12M
Nominal flow	20 l/min (5.3 US gpm)	40 l/min (10.5 US gpm)	60 l/min (15.8 US gpm)
Max. pressure	port 1	210 bar (3050 psi)	250 bar (3600 psi)
	port 2,3,4	210 bar (3050 psi)	320 bar (4600 psi)
Oil leakage	at 210 bar (3050 psi) 40 cm <sup>3</sup> /min (2.44 in <sup>3</sup> /min)	80 cm <sup>3</sup> /min (4.88 in <sup>3</sup> /min)	200 cm <sup>3</sup> /min (12.20 in <sup>3</sup> /min)
Fluid	mineral based oil		
Viscosity	10-200 cSt		
Max level of contamination	18/16/13 ISO4406		
Fluid temperature	with NBR seals	from -20°C (-4°F) to 80°C (176°F)	
	with FPM seals	from -20°C (-4°F) to 100°C (212°F)	
Environmental temp. for working conditions	from -20°C (-4°F) to 50°C (122°F)		
Cavity	SAE 08/4	SAE 10/4	SAE 12/4
Coils type*	BER	BC	BH
Nominal voltages	12 VDC - 24 VDC ± 10%	12 VDC - 24 VDC ± 10%	12 VDC - 24 VDC ± 10%
Power rating	22.8 W (12 VDC)	26.1 W (12 VDC)	33 W (12/24 VDC)
	22.5 W (24 VDC)	25.9 W (24 VDC)	
Weight	0.20 kg (0.44 lb)	0.50 kg (1.10 lb)	0.73 kg (1.61 lb)

NOTE - For different conditions, please contact Walvoil Sales Dpt. - \*For coils further features see from page 206.

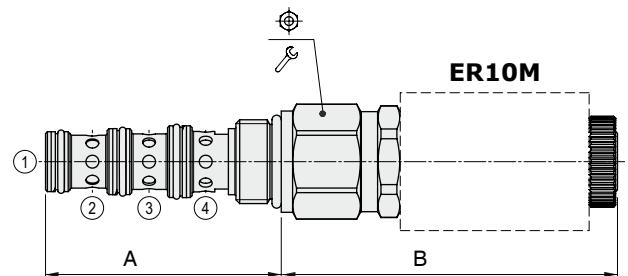
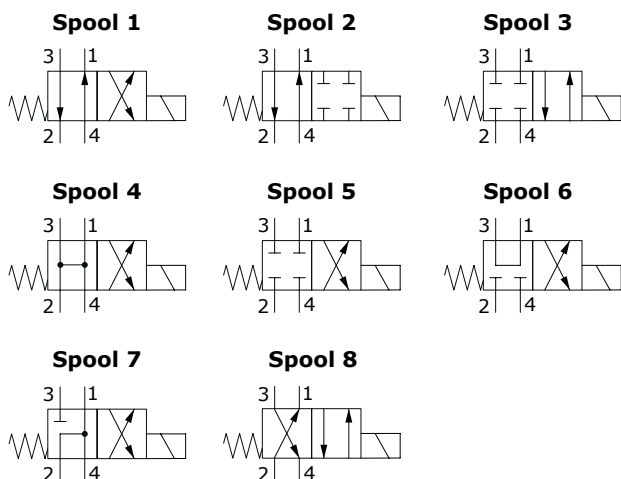

Valve type	A		B		⊕	⌘	Nm	lbft
	mm	in	mm	in				
ER08M/..NB	53.6	2.11	75	2.95	24	30	22	
ER10M/..NB	62.4	2.46	89	3.50	27	50	37	
ER12M/..NB	81.4	3.20	85.5	3.37	32	85	63	

For dimensions with different type of emergency see page 213

### Ordering codes and description composition

#### ER08M/10 NB

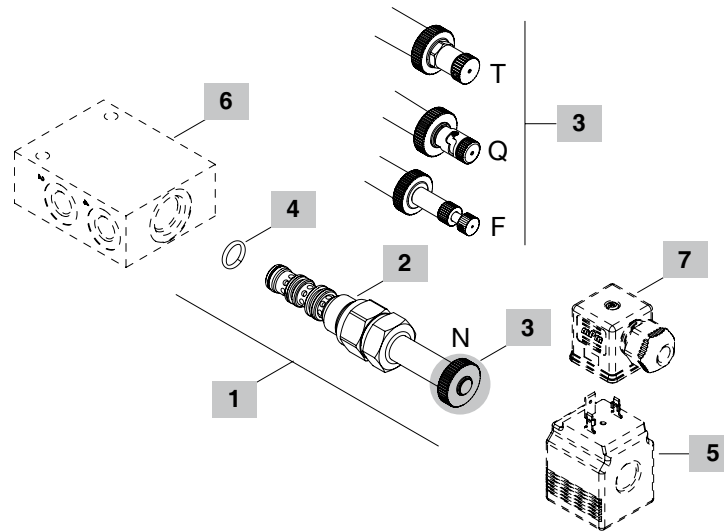
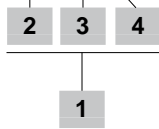

#### 1 Cartridges

TYPE	CODE	DESCRIPTION
<b>SAE cavity 08/4</b>		
ER08M/10NB	0ER08002016	Without emergency, spool 1
ER08M/20NB	0ER08002017	Without emergency, spool 2
ER08M/30NB	0ER08002018	Without emergency, spool 3
ER08M/40NB	0ER08002019	Without emergency, spool 4
ER08M/50NB	0ER08002020	Without emergency, spool 5
ER08M/60NB	0ER08002021	Without emergency, spool 6
ER08M/70NB	0ER08002022	Without emergency, spool 7
ER08M/80NB	0ER08002023	Without emergency, spool 8
<b>SAE cavity 10/4</b>		
ER10M/10NB	0ER10002023	Without emergency, spool 1
ER10M/20NB	0ER10002024	Without emergency, spool 2
ER10M/30NB	0ER10002025	Without emergency, spool 3
ER10M/40NB	0ER10002026	Without emergency, spool 4
ER10M/50NB	0ER10002027	Without emergency, spool 5
ER10M/60NB	0ER10002028	Without emergency, spool 6
ER10M/70NB	0ER10002029	Without emergency, spool 7
ER10M/80NB	0ER10002030	Without emergency, spool 8
<b>SAE cavity 12/4</b>		
ER12M/10NB	0ER12002021	Without emergency, spool 1
ER12M/20NB	0ER12002023	Without emergency, spool 2
ER12M/50NB	0ER12002024	Without emergency, spool 5
ER12M/80NB	0ER12002022	Without emergency, spool 8

#### 2 Spool

TYPE	DESCRIPTION
1	Spool 1
2	Spool 2
3	Spool 3
4	Spool 4
5	Spool 5
6	Spool 6
7	Spool 7
8	Spool 8

#### 3 Emergency

TYPE	DESCRIPTION
N	Without emergency
F	Pull button type
Q	Pull type with detent
T	Screw type

#### 4 Seals

TYPE	DESCRIPTION
B	<b>NBR (Buna)</b> o-ring seals, std configuration (*)
V	<b>FPM (Viton)</b> o-ring seals, contact Sales Dept.

Note (\*): for ER12M, NBR and polyurethane D-ring

#### 5 Coils

TYPE	CODE	DESCRIPTION
<b>BER 12VDC-ISO4400</b>	4SLE001200	12VDC-ISO4400 coil for ER08M
<b>BC 12VDC-ISO4400</b>	4SL8000120	12VDC-ISO4400 coil for ER10M
<b>BH 12VDC-ISO4400</b>	4SLD001200	12VDC-ISO4400 coil for ER12M

For complete coils list see from page 206

#### 6 Valve body

TYPE	CODE	DESCRIPTION
<b>SAE 08/4-G 3/8</b>	3CC0840C11	Aluminium body for cavity 08 valve, G3/8 std thread
<b>SAE 10/4-G 3/8</b>	3CC1020C11	Aluminium body for cavity 10 valve, G3/8 std thread
<b>SAE 12/4-G 1/2</b>	3CC1240D11	Aluminium body for cavity 12 valve, G1/2 thread

Note: aluminium body can stand up to 210 bar (3050 psi)  
For steel bodies or different threading see from page 219

#### 7 Connector

TYPE	CODE	DESCRIPTION
<b>ISO4400</b>	4CN1009995	Connector

For complete connectors list see from page 206

# Directional control valves

Directional solenoid valves - 4 way / 2 positions

**ER..M type**

## Rating diagrams

**ER08M pressure drop vs. flow**  
- Spool 1 -

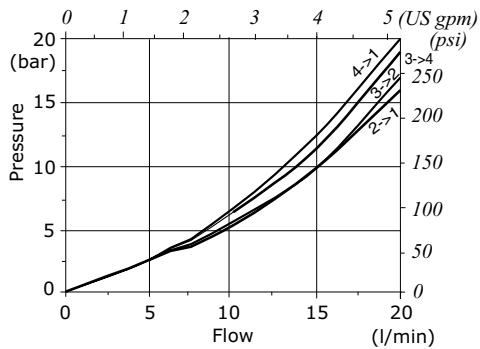

**ER08M pressure drop vs. flow**  
- Spool 2 -

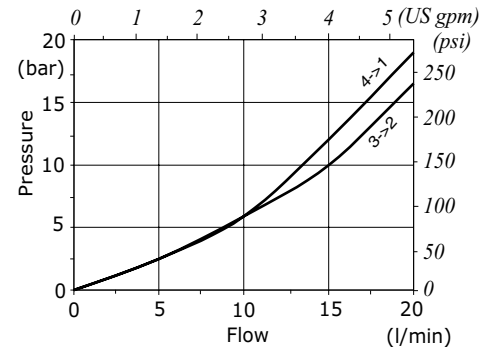

**ER08M pressure drop vs. flow**  
- Spool 3 -

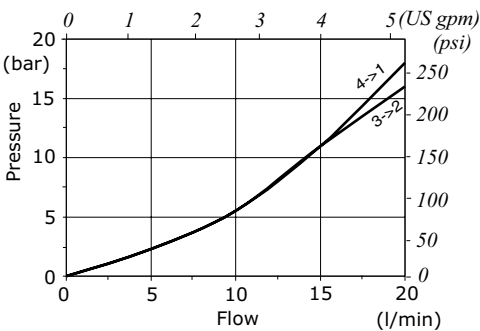

**ER08M pressure drop vs. flow**  
- Spool 4 -

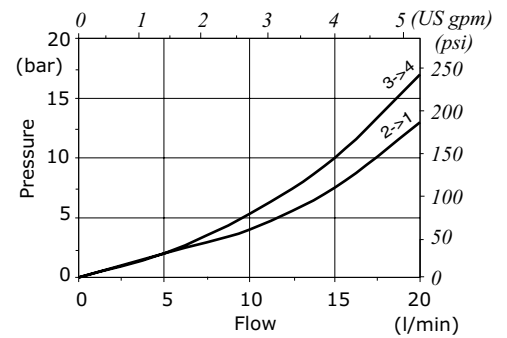

**ER08M pressure drop vs. flow**  
- Spool 5 -

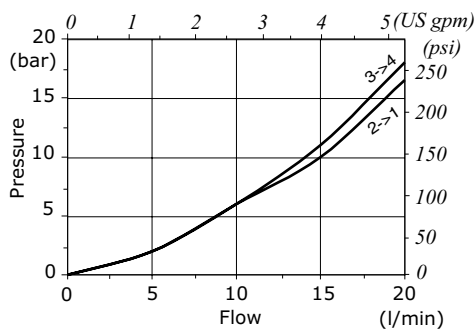

**ER08M pressure drop vs. flow**  
- Spool 6 -

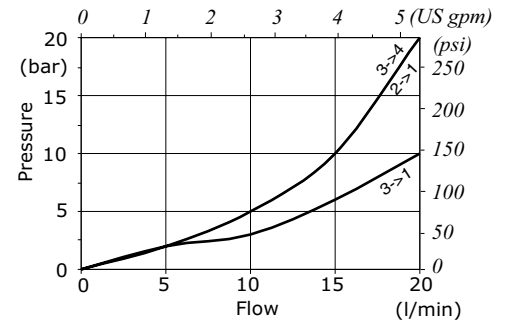

**ER08M pressure drop vs. flow**  
- Spool 7 -

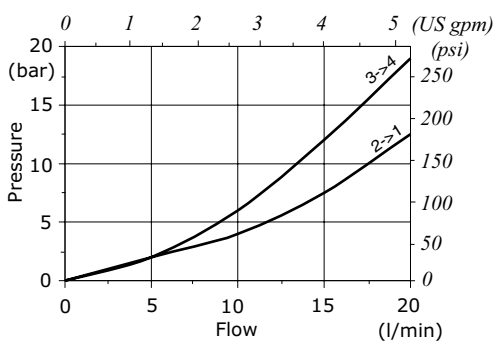

**ER08M performance limit**

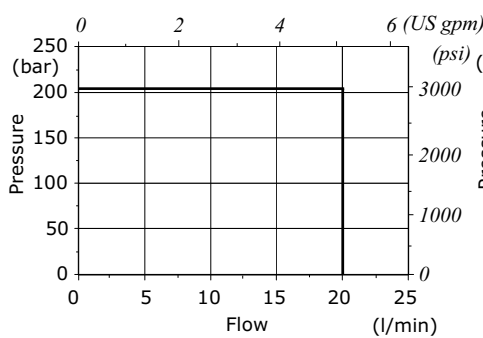

**ER08M pressure drop vs. flow**  
- Spool 8 -

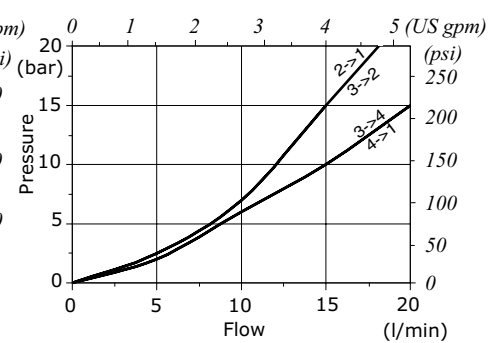

**Rating diagrams**

**ER10M pressure drop vs. flow**  
- Spool 1 -

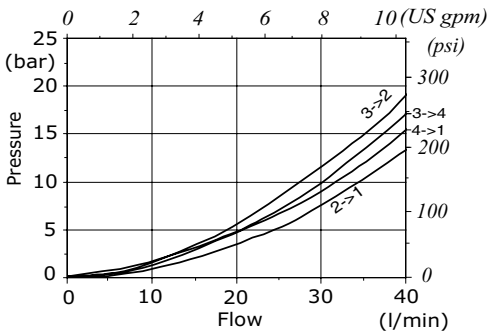

**ER10M pressure drop vs. flow**  
- Spool 2 -

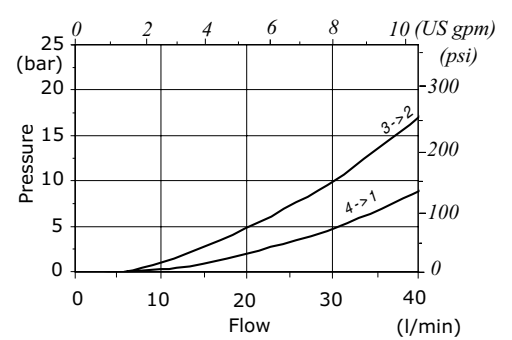

**ER10M pressure drop vs. flow**  
- Spool 3 -

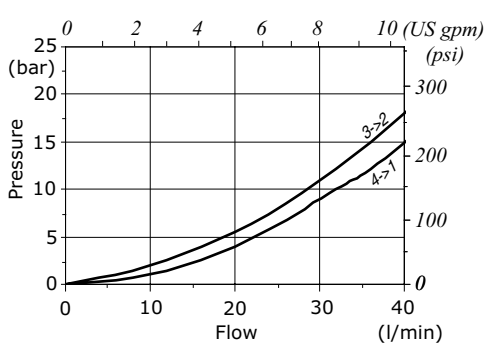

**ER10M pressure drop vs. flow**  
- Spool 4 -

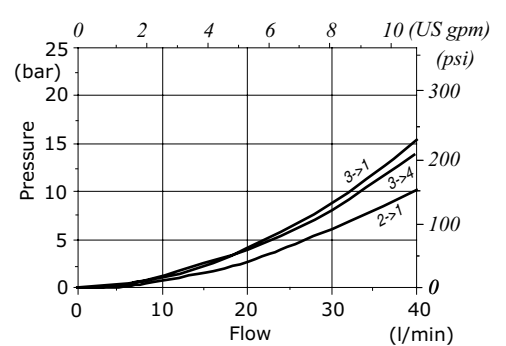

**ER10M pressure drop vs. flow**  
- Spool 5 -

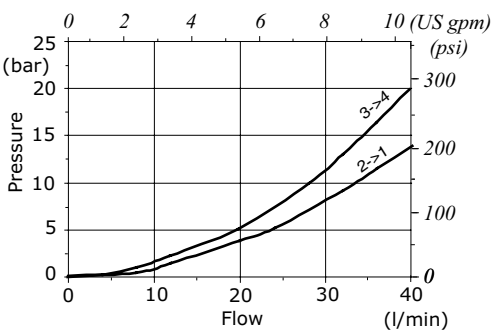

**ER10M pressure drop vs. flow**  
- Spool 6 -

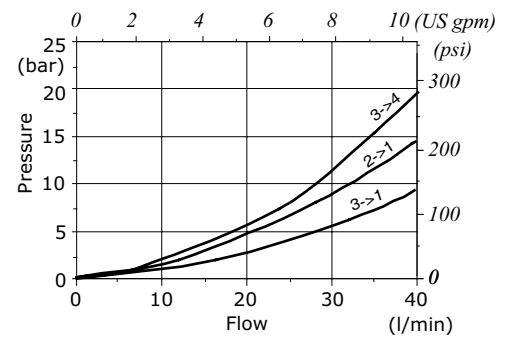

**ER10M pressure drop vs. flow**  
- Spool 7 -

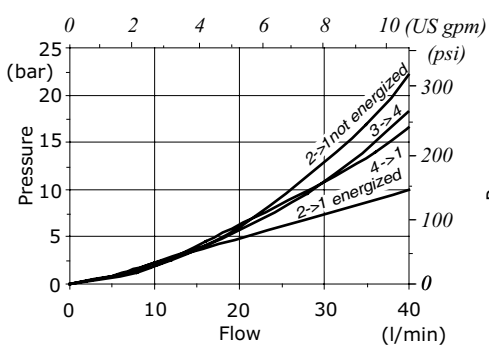

**ER10M performance limit**

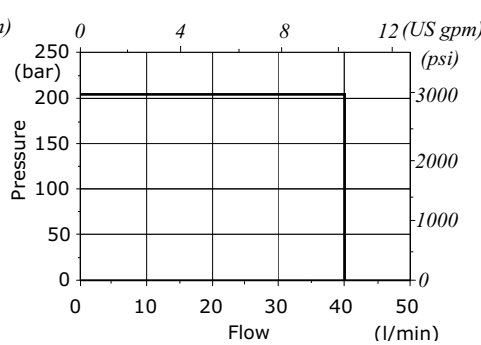

**ER10M pressure drop vs. flow**  
- Spool 8 -

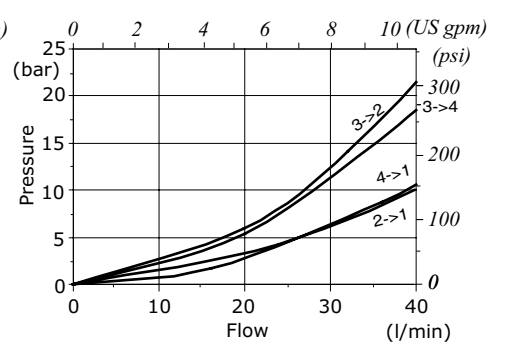

# Directional control valves

Directional solenoid valves - 4 way / 2 positions

**ER..M type**

## Rating diagrams

**ER12M pressure drop vs. flow**  
- Spool 1 -

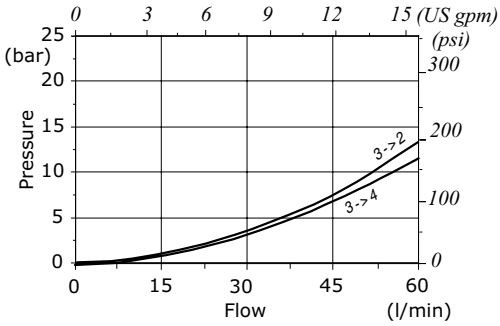

**ER12M pressure drop vs. flow**  
- Spool 2 -

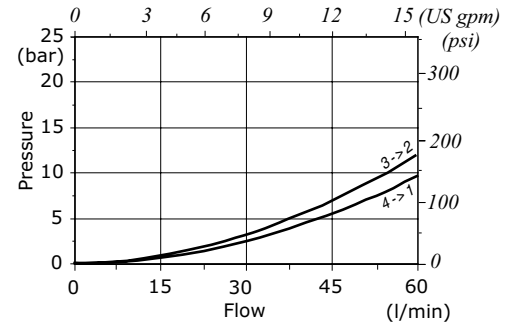

**ER12M pressure drop vs. flow**  
- Spool 5 -

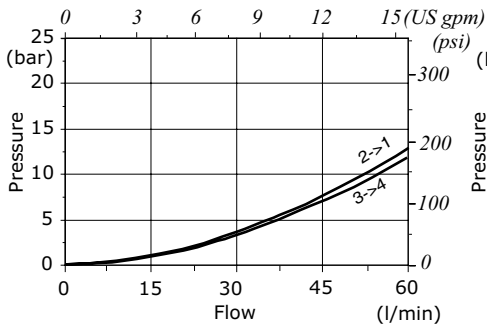

**ER12M performance limit**

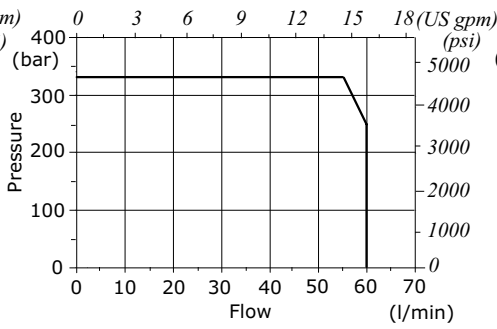

**ER12M pressure drop vs. flow**  
- Spool 8 -

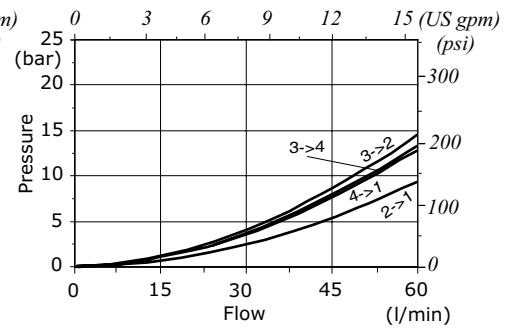





## ET..M type directional solenoid valve - 4 way / 3 positions

- Direct acting
- Spool type
- From SAE08 to SAE10 cavities

Technical specifications and diagrams are measured with mineral oil of 46 cSt viscosity at 40°C (104°F) temperature.

	ET08M	ET10M
Nominal flow	18 l/min (4.7 US gpm)	40 l/min (10.5 US gpm)
Max. pressure	210 bar (3050 psi)	
Oil leakage	at 210 bar (3050 psi) 40 cm <sup>3</sup> /min (2.44 in <sup>3</sup> /min)	80 cm <sup>3</sup> /min (4.88 in <sup>3</sup> /min)
Fluid	mineral based oil	
Viscosity	10-200 cSt	
Max level of contamination	18/16/13 ISO4406	
Fluid temperature	with NBR seals with FPM seals	from -20°C (-4°F) to 80°C (176°F) from -20°C (-4°F) to 100°C (212°F)
Environmental temp. for working conditions	from -20°C (-4°F) to 50°C (122°F)	
Cavity	SAE 08/4	SAE 10/4
Coils type*	BER	BC
Nominal voltages	12 VDC - 24 VDC ± 10%	12 VDC - 24 VDC ± 10%
Power rating	22.8 W (12 VDC) - 22.5 W (24 VDC)	26.1 W (12 VDC) - 25.9 W (24 VDC)
Weight	0.25 kg (0.44 lb)	0.45 kg (1.10 lb)

NOTE - For different conditions, please contact Walvoil Sales Dpt. - \*For coils further features see from page 206.

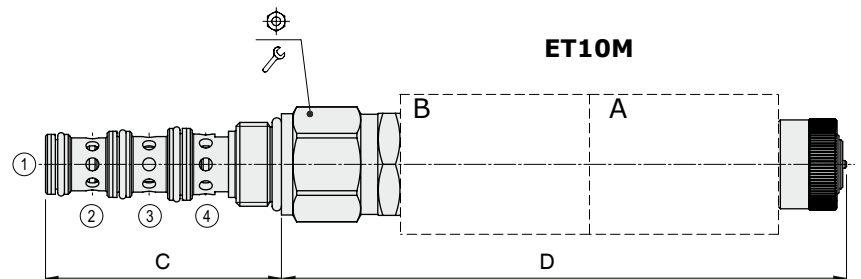
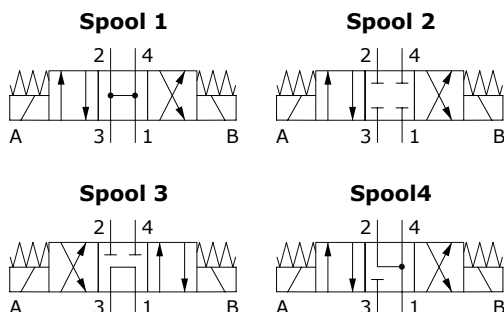

Valve type	C		D				
	mm	in	mm	in			Nm
ET08M/..NB	53.6	2.11	120	4.72	24	30	22
ET10M/..NB	62.4	2.46	148.5	5.85	27	50	37

For dimensions with different type of emergency see page 213

### Ordering codes and description composition

ET08M/10 NB

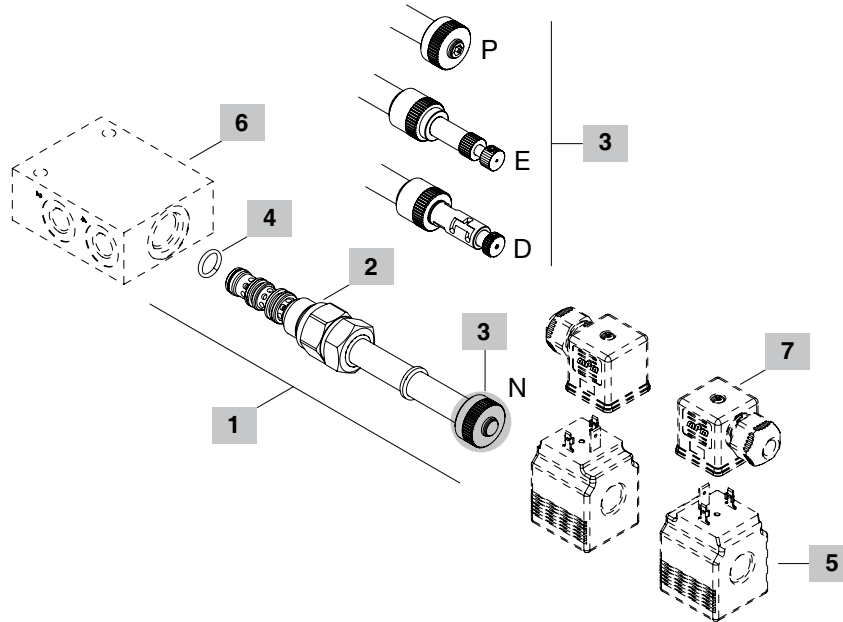
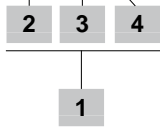

#### 1 Cartridges

TYPE	CODE	DESCRIPTION
<b>SAE cavity 08/4</b>		
ET08M/10NB	0ET08002017	Without emergency, spool 1
ET08M/20NB	0ET08002019	Without emergency, spool 2
ET08M/30NB	0ET08002020	Without emergency, spool 3
ET08M/40NB	0ER08002018	Without emergency, spool 4
<b>SAE cavity 10/4</b>		
ET10M/10NB	0ET10002023	Without emergency, spool 1
ET10M/20NB	0ET10002024	Without emergency, spool 2
ET10M/30NB	0ET10002025	Without emergency, spool 3
ET10M/40NB	0ET10002026	Without emergency, spool 4

#### 2 Spool

TYPE	DESCRIPTION
1	Spool 1
2	Spool 2
3	Spool 3
4	Spool 4

#### 3 Emergency

TYPE	DESCRIPTION
N	Without emergency
E	Pull/push-button type
D	Detent push/pull type
P	Push-button type

#### 4 Seals

TYPE	DESCRIPTION
B	<b>NBR (Buna)</b> o-ring seals, std configuration
V	<b>FPM (Viton)</b> o-ring seals, contact Sales Dept.

#### 5 Coils

TYPE	CODE	DESCRIPTION
BER 12VDC	4SLE001200	12VDC-ISO4400 coil for ET08M
BC 12VDC	4SL8000120	12VDC-ISO4400 coil for ET10M

For complete coils list see from page 206

#### 6 Valve body

TYPE	CODE	DESCRIPTION
SAE 08/4-G 3/8	3CC0840C11	Aluminium body for cavity 08 valve, G 3/8 std thread
SAE 10/4-G 3/8	3CC1040C11	Aluminium body for cavity 10 valve, G 3/8 std thread

For steel bodies or different threading see from page 219

#### 7 Connector

TYPE	CODE	DESCRIPTION
ISO4400	4CN1009995	Connector

For complete connectors list see from page 206



# Directional control valves

Directional solenoid valves - 4 way / 3 positions

**ET..M type**

## Rating diagrams

**ET08M pressure drop vs. flow**  
- Spool 1 -

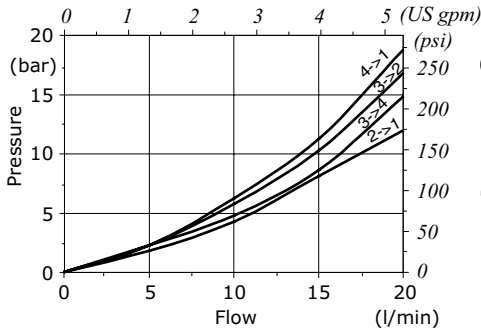

**ET08M pressure drop vs. flow**  
- Spool 2 -

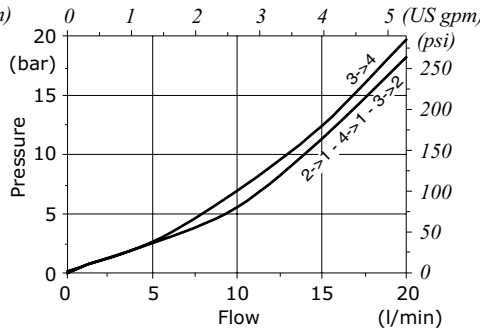

**ET08M pressure drop vs. flow**  
- Spool 3 -

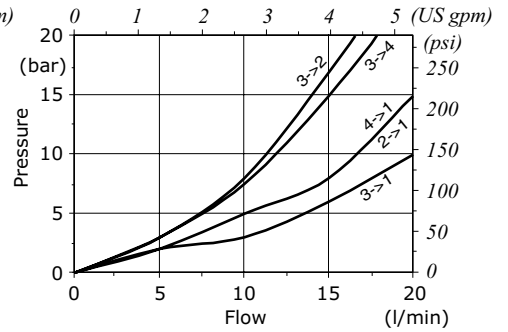

**ET08M pressure drop vs. flow**  
- Spool 4 -

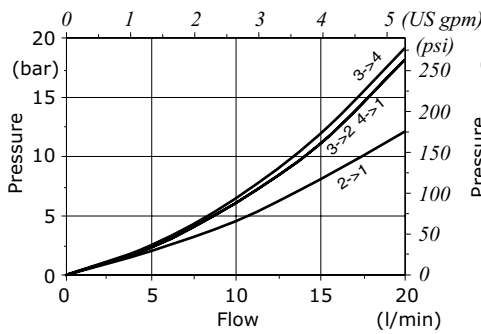

**ET08M performance limit**

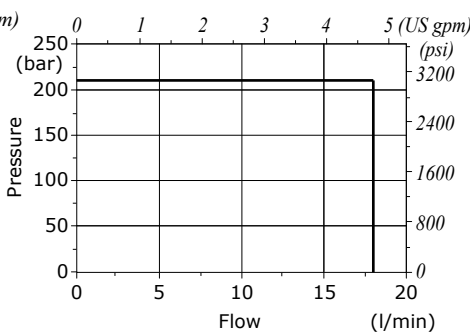

**ET10M pressure drop vs. flow**  
- Spool 1 -

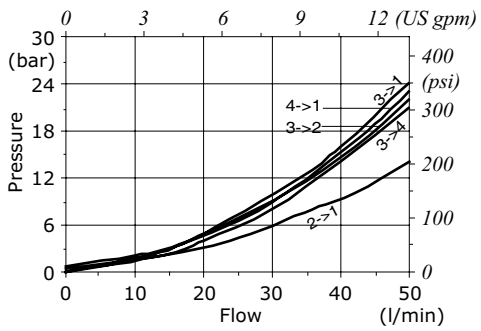

**ET10M pressure drop vs. flow**  
- Spool 2 -

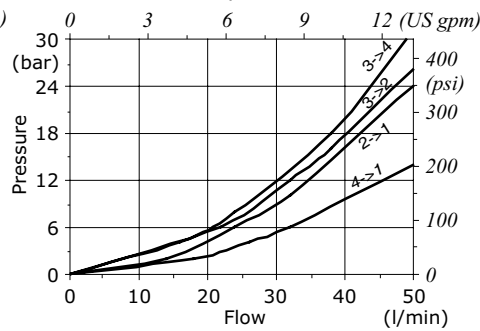

**ET10M pressure drop vs. flow**  
- Spool 3 -

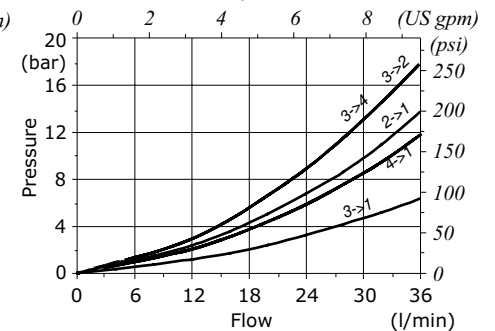

**ET10M pressure drop vs. flow**  
- Spool 4 -

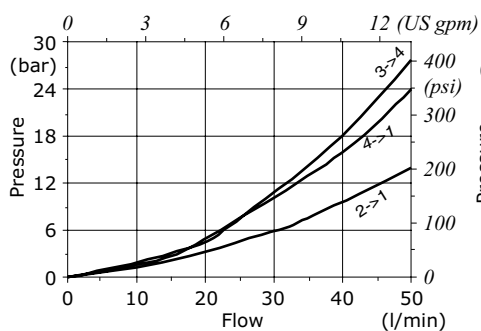

**ET10M performance limit**

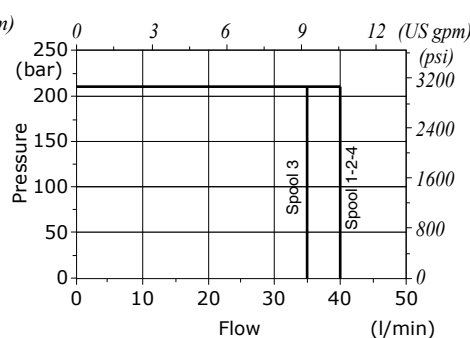





## ET12A type directional solenoid valve - 4 way / 3 positions

- Direct acting
- Spool type

Technical specifications and diagrams are measured with mineral oil of 46 cSt viscosity at 40°C (104°F) temperature.

		<b>ET12A</b>
Nominal flow		40 l/min (10.5 US gpm)
Max. pressure		210 bar (3050 psi)
Oil leakage	at 210 bar (3050 psi)	120 cm <sup>3</sup> /min (7.32 in <sup>3</sup> /min)
Fluid		mineral based oil
Viscosity		10-200 cSt
Max level of contamination		18/16/13 ISO4406
Fluid temperature	<i>with NBR seals</i> <i>with FPM seals</i>	from -20°C (-4°F) to 80°C (176°F) from -20°C (-4°F) to 100°C (212°F)
Environmental temp. for working conditions		from -20°C (-4°F) to 50°C (122°F)
Cavity		SAE 12/4
Coil type*		BIN 22
Nominal voltages		12 VDC - 24 VDC ± 10%
Power rating		32.6 W (12 VDC) - 31 W (24 VDC)
Weight		0.720 kg (1.59 lb)

NOTE - For different conditions, please contact Walvoil Sales Dpt. - \*For coils further features see from page 206.

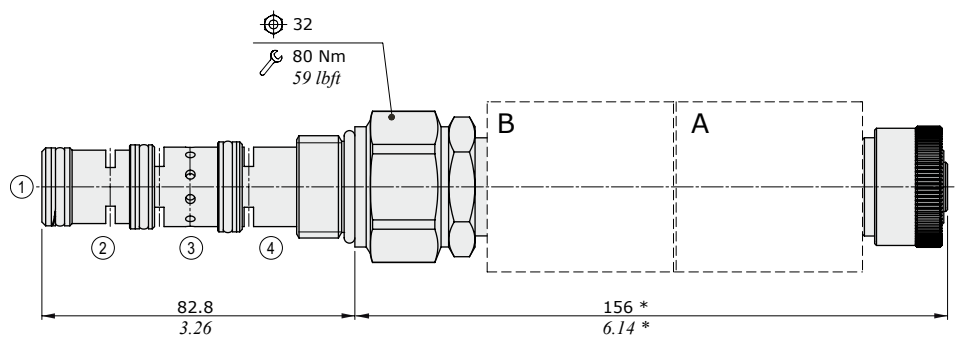
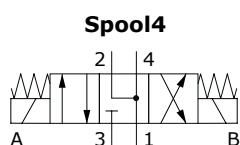
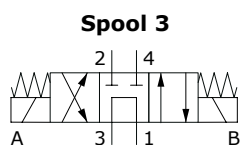
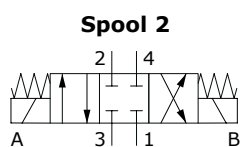
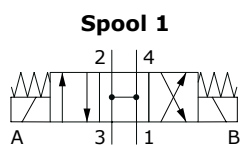

NOTE (\*) : dimensions for configuration **ET12A/10NB**, for dimensions with different type of emergency see page 213.

### Ordering codes and description composition

ET12A/10 NB

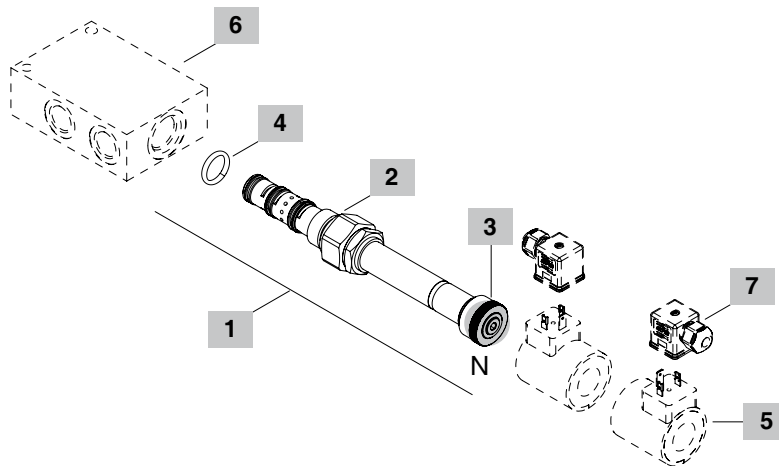
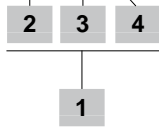

#### 1 Cartridges

TYPE	CODE	DESCRIPTION
<b>SAE cavity 12/4</b>		
<b>ET12A/10NB</b>	0ET12002012	Without emergency, spool 1
<b>ET12A/10PB</b>	0ET12002013	Push-button emergency, spool 1
<b>ET12A/20NB</b>	0ET12002009	Without emergency, spool 2
<b>ET12A/20PB</b>	0ET12002014	Push-button emergency, spool 2
<b>ET12A/30NB</b>	0ET12002010	Without emergency, spool 3
<b>ET12A/30PB</b>	0ET12002015	Push-button emergency, spool 3
<b>ET12A/40NB</b>	0ET12002011	Without emergency, spool 4
<b>ET12A/40PB</b>	0ET12002016	Push-button emergency, spool 4

#### 2 Spool

TYPE	DESCRIPTION
<b>1</b>	Spool 1
<b>2</b>	Spool 2
<b>3</b>	Spool 3
<b>4</b>	Spool 4

#### 3 Emergency

TYPE	DESCRIPTION
<b>N</b>	Without emergency
<b>P</b>	Push button type

#### 4 Seals

TYPE	DESCRIPTION
<b>B</b>	<b>NBR (Buna)</b> o-ring seals, std configuration
<b>V</b>	<b>FPM (Viton)</b> o-ring seals, contact Sales Dept.

#### 5 Coils

TYPE	CODE	DESCRIPTION
<b>BIN22 12VDC</b>	4SL6000128	12VDC-ISO4400 coil

For complete coils list see from page 206

#### 6 Valve body

TYPE	CODE	DESCRIPTION
<b>SAE 12/4-G 1/2</b>	3CC1240D11	Aluminium body for cavity 12 valve, G1/2 std thread

For steel bodies or different threading see from page 219

#### 7 Connector

TYPE	CODE	DESCRIPTION
<b>ISO4400</b>	4CN1009995	Connector

For complete connectors list see from page 206

**Rating diagrams**

**ET12A pressure drop vs. flow**  
 - Spool 1 -

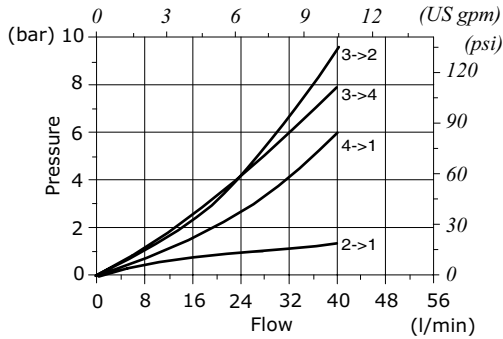

**ET12A pressure drop vs. flow**  
 - Spool 2 -

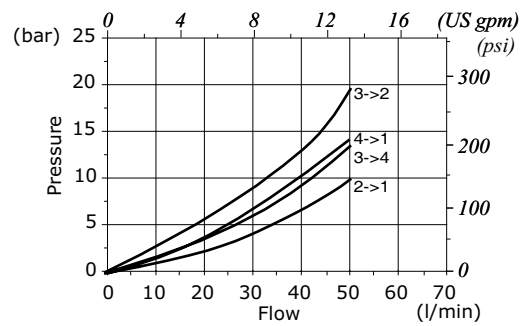

**ET12A pressure drop vs. flow**  
 - Spool 3 -

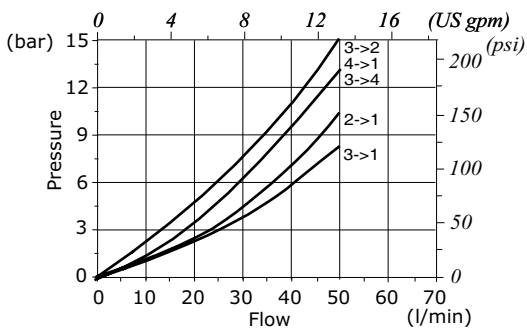

**ET12A pressure drop vs. flow**  
 - Spool 4 -

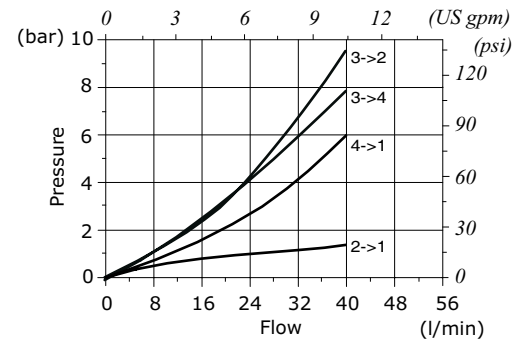

## Types and ordering codes

Valve type	Coil	Voltage	Connector					
			ISO4400	Deutsch DT	AMP JPT	Packard Weather-pack	Packard Metri-pack	Flying leads
<b>Directional solenoid valves</b>								
EA08A	BE	12 VDC	4SL1000120A	4SL1000123A <sup>(6)</sup> 4SL1000140 <sup>(3-6)</sup> 4SL1000124 <sup>(2)</sup>	-	-	-	4SL1000122A
		24 VDC	4SL1000240A 4SL1030240 <sup>(1)</sup>	4SL1002401 <sup>(6)</sup>	4SL1000125A <sup>(3-5)</sup>	-	-	-
		110 VDC	4SL1011100 4SL1031100 <sup>(1)</sup>	-	-	-	-	-
		220 VDC	4SL1022200 4SL1032200 <sup>(1)</sup>	-	-	-	-	-
EA08B EW08A EJ08F EJ08G	BT	10 VDC	4SL3000100	-	-	-	-	-
		12 VDC	4SL3000120 4SL3000126 <sup>(4)</sup>	4SL3000130 <sup>(6)</sup> 4SL3000134 <sup>(3-6)</sup> 4SL3000128 <sup>(2)</sup>	4SL3000122 <sup>(5)</sup> 4SL3001200 <sup>(3-5)</sup>	4SL3000124 <sup>(2)</sup>	4SL3000127 <sup>(2)</sup>	4SL300012C
		24 VDC	4SL3000240 4SL3030240 <sup>(1)</sup>	4SL3000249 <sup>(6)</sup> 4SL300024C <sup>(3-6)</sup>	4SL3000248 <sup>(5)</sup>	-	-	4SL3000246
		26 VDC	4SL3000260	-	-	-	-	-
		48 VDC	4SL3000480 4SL3030480 <sup>(1)</sup>	-	-	-	-	-
		110 VDC	4SL3001100 4SL3031100 <sup>(1)</sup>	-	-	-	-	-
		220 VDC	4SL3002200 4SL3032200 <sup>(1)</sup>	-	-	-	-	-
EW10M	BH	12 VDC	4SLD001200A	4SLD001201A <sup>(6)</sup>	4SLD001207A <sup>(6)</sup>	-	-	4SLD001203A
		24 VDC	4SLD002400A	4SLD002401A <sup>(6)</sup>	4SLD002407A <sup>(6)</sup>	-	-	4SLD002403A
		10 VDC	4SLE001000A	-	-	-	-	-
EE08A EC..M EF..M EJ8CA EJ08M ER08M ET08M EL08B	BER	12 VDC	4SLE001200A 4SLE001217A <sup>(3)</sup>	4SLE001201A <sup>(5)</sup> 4SLE001209A <sup>(3-5)</sup> 4SLE001202A <sup>(6)</sup> 4SLE001216A <sup>(3-6)</sup> 4SLE001206A <sup>(2)</sup>	4SLE001203A <sup>(5)</sup> 4SLE001211A <sup>(3-5)</sup>	4SLE001210A <sup>(2)</sup>	4SLE001214 <sup>(2)</sup>	4SLE001207A
		24 VDC	4SLE002400A 4SLE002408A <sup>(3)</sup> 4SLE302400A <sup>(1)</sup>	4SLE002401A <sup>(5)</sup> 4SLE002407A <sup>(3-5)</sup> 4SLE002402A <sup>(6)</sup>	4SLE002403A <sup>(5)</sup>	-	-	4SLE002404A
		48 VDC	4SLE004800A 4SLE304800A <sup>(1)</sup>	-	-	-	-	-
		110 VDC	4SLE011000A 4SLE311000A <sup>(1)</sup>	-	-	-	-	-
		220 VDC	4SLE022000A 4SLE322000A <sup>(1)</sup>	-	-	-	-	-
		EE10A EW10A EW10B	BIN19	10,5 VDC	4SL6000100	-	-	-
12 VDC	4SL6000121			-	-	-	-	-
24 VDC	4SL6000240			-	-	-	-	-
EE12A EW12A EW12C EJ12A ET12A	BIN22	12 VDC	4SL6000128	-	-	-	-	-
		24 VDC	4SL6000245	-	-	-	-	-
EJ10M EL08A ER10M ET10M	BC	10,5 VDC	4SL8000110	-	-	-	-	-
		12 VDC	4SL8000120	4SL800012BA <sup>(6)</sup> 4SL8001201A <sup>(6-3)</sup>	4SL8000127 <sup>(5)</sup> 4SL8000130 <sup>(5-3)</sup>	-	-	4SL800012A
		24 VDC	4SL8000240 4SL8030240 <sup>(1)</sup>	4SL8000243 <sup>(6)</sup>	4SL8000241 <sup>(5)</sup>	-	-	4SL8000242
		26 VDC	4SL8000260	-	-	-	-	-
		48 VDC	4SL8030480 <sup>(1)</sup>	-	-	-	-	-
		110 VDC	4SL8031100 <sup>(1)</sup>	-	-	-	-	-
EL10C	BQ16	12 VDC	4SL8000121	4SL8000128 <sup>(5)</sup>	-	-	4SL8000124 <sup>(2)</sup>	4SL8000125
		24 VDC	4SL8002400	4SL8000245 <sup>(5)</sup>	-	-	-	-

Types and ordering codes

Valve type	Coil	Voltage	Connector					
			ISO4400	Deutsch DT	AMP JPT	Packard Weather-pack	Packard Metri-pack	Flying leads
<b>Pressure relief valves - Pressure reducing valves - Flow control pressure compensated valves</b>								
MC08Y MP16Y RD08W RM..W RP..W	MP35	12 VDC	4SL4000120	-	-	-	-	-
		24 VDC	4SL4000240	-	-	-	-	-
MC10X MP..T MP..X PP..X PU..X EE..X EC..T	BQP19	12 VDC	4SL5000126A	4SL5000125A <sup>(6)</sup>	4SL5000129A <sup>(5)</sup>	-	-	-
		24 VDC	4SL5000245A	4SL5000244A <sup>(6)</sup>	4SL5000248A <sup>(5)</sup>	-	-	-
	BH	12 VDC	4SLD001200A	4SLD001201A <sup>(6)</sup>	4SLD001207A <sup>(6)</sup>	-	-	4SLD001203A
		24 VDC	4SLD002400A	4SLD002401A <sup>(6)</sup>	4SLD002407A <sup>(6)</sup>	-	-	4SLD002403A
RD08S RD08T	MSM19	12 VDC	4SL5000128	-	-	-	5SL5000122 <sup>(2)</sup>	4SL5000122
		24 VDC	4SL5000247	-	-	-	5SL5000243 <sup>(2)</sup>	4SL5000243
RP08X	BDP19	12 VDC	4SL5000120	-	-	-	-	-
		24 VDC	4SL5000240	-	-	-	-	-
<b>Mating connectors</b> (For connector with rectifier see following table)			4CN1009995	5CON140031	5CON003	5CON001	5CON017	-

Notes: <sup>(1)</sup> supply with AC and use only with rectifier connector - <sup>(2)</sup> with flying leads - <sup>(3)</sup> with bidirectional diode - <sup>(5)</sup> with unidirectional diode  
<sup>(5)</sup> integrated perpendicular type - <sup>(6)</sup> integrated parallel type

Voltage	ISO 4400 mating connector with rectifier			
	BT type coil	BE type coil	BER type coil	BC type coil
24 VDC	4CN3010240	4CN1010240	4CN1010240	4CN3010240
48 VDC	4CN3010480	4CN1010480	4CN1010480	4CN3010480
110 VDC	4CN3011100	4CN1011100	4CN1011100	4CN3011100
220 VDC	4CN3012200	4CN1012200	4CN1012200	4CN3012200

Dimensional data and features

BE type

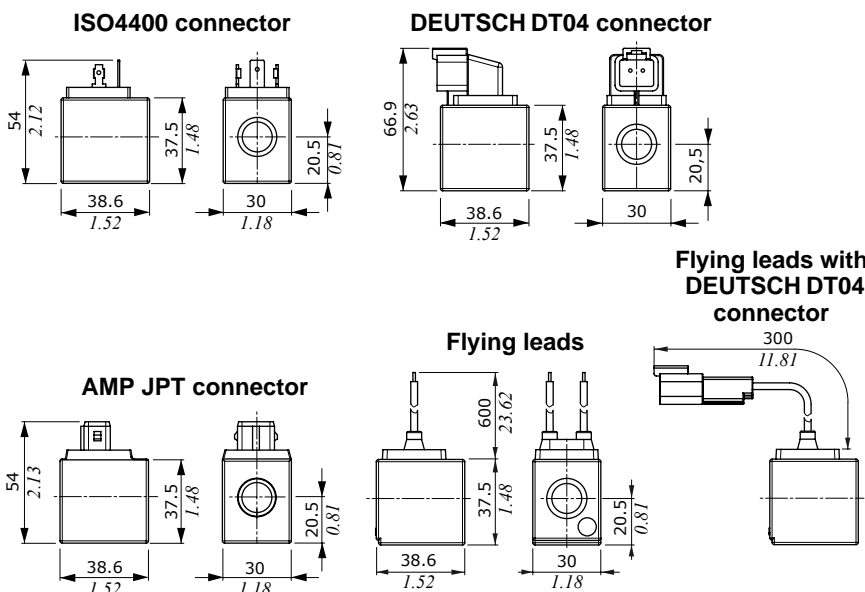

Features

- Nominal voltage tolerance : ±10%
- Power rating . . . . . : 18.7 W - 12 VDC  
 : 18.6 W - 24 VDC  
 : 17.3 W - 110 VDC  
 : 15.7 W - 220 VDC  
 : 18.3 W - 24 RAC  
 : 16 W - 110 RAC  
 : 16 W - 220 RAC
- Max. operating current . . . : 1.56 A - 12 VDC  
 : 0.77 A - 24 VDC  
 : 0.157 A - 110 VDC  
 : 0.08 A - 220 VDC  
 : 0.85 A - 24 RAC  
 : 0.16 A - 110 RAC  
 : 0.08 A - 220 RAC
- Coil insulation . . . . . : Class F (155°C - 311°F)
- Weather protection . . . . . : IP65 - ISO4400  
 : IP69K - Deutsch DT
- Insertion . . . . . : 100%





Dimensional data and features

**BER type**

**ISO4400 connector**

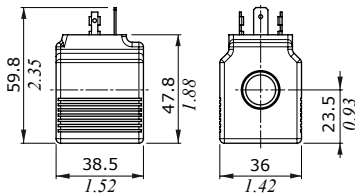

**DEUTSCH DT04 connector**  
(perpendicular type)

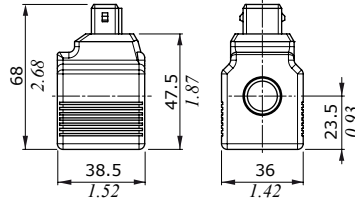

**DEUTSCH DT04 connector**  
(parallel type)

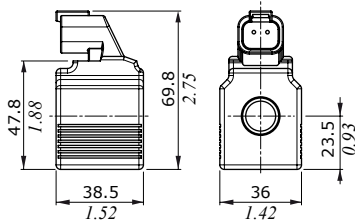

**AMP JPT connector**

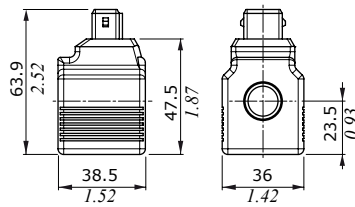

**Features**

- Nominal voltage tolerance : ±10%
- Power rating . . . . . : 19.2 W - 10/12/24/48/  
110/220 VDC  
: 19 W - 24/110/220 RAC  
: 19.2 W - 48 RAC
- Max. operating current . . . : 1.9 A - 10 VDC  
: 1.61 A - 12 VDC  
: 0.80 A - 24 VDC  
: 0.40 A - 48 VDC  
: 0.17 A - 110 VDC  
: 0.09 A - 220 VDC  
: 0.89 A - 24 RAC  
: 0.45 A - 48 RAC  
: 0.19 A - 110 RAC  
: 0.09 A - 220 RAC
- Coil insulation . . . . . : Class H (180°C - 356°F)
- Weather protection . . . . . : IP65 - ISO4400  
: IP69K - Deutsch DT  
: IP65 - AMP JPT  
: IP67 - Weatherpack  
: IP67 - Metri-pack
- Insertion . . . . . : 100%

**With flying leads**

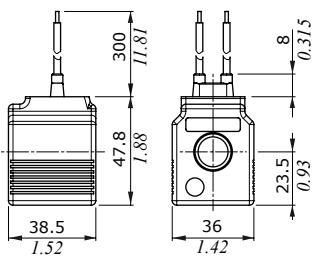

**Flying leads with DEUTSCH DT04 connector**

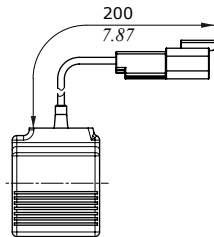

**Flying leads with PACKARD WEATHER-PACK connector**

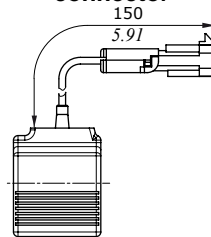

**Flying leads with PACKARD METRI-PACK connector**

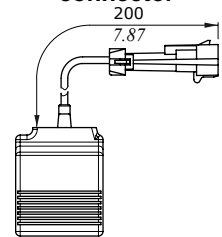

**BIN19 type**

**ISO4400 connector**

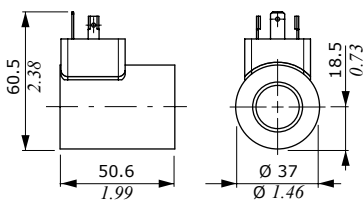

**BIN22 type**

**ISO4400 connector**

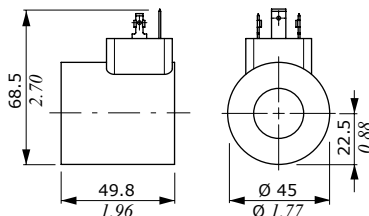

**Features**

- Nominal voltage tolerance : ±10%
- Coil insulation . . . . . : Class F (155°C - 311°F)
- Weather protection . . . . . : IP65 - ISO4400
- Insertion . . . . . : 100%
- BIN19**
- Power rating . . . . . : 26 W - 10.5 VDC  
: 29 W - 12 VDC  
: 31 W - 24 VDC
- Max. operating current . . . : 2.48 A - 10.5 VDC  
: 2.41 A - 12 VDC  
: 1.29 A - 24 VDC
- BIN22**
- Power rating . . . . . : 32.6 W - 12 VDC  
: 31 W - 24 VDC
- Max. operating current . . . : 2.72 A - 12 VDC  
: 1.29 A - 24 VDC

Dimensional data and features

BC type

ISO4400 connector

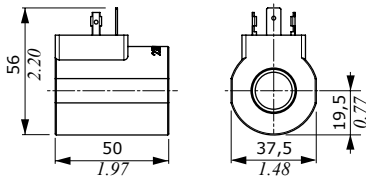

DEUTSCH DT04 connector

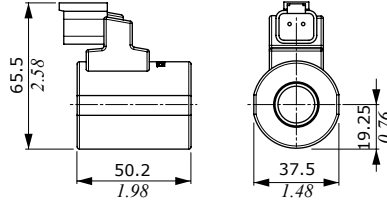

Features

- Nominal voltage tolerance : ±10%
- Power rating . . . . . : 26.9 W - 10.5 VDC  
: 26.2 W - 12 VDC  
: 25.9 W - 24 VDC  
: 24 W - 26 VDC  
: 26 W - 24/48/110/220 RAC
- Max. operating current . . . : 2.6 A - 10.5 VDC  
: 2.19 A - 12 VDC  
: 1.08 A - 24 VDC  
: 0.92 A - 26 VDC  
: 1.2 A - 24 RAC  
: 0.6 A - 48 RAC  
: 0.3 A - 110 RAC  
: 0.15 A - 220 RAC
- Coil insulation . . . . . : Class H (180°C - 356°F)
- Weather protection . . . . . : IP65 - ISO4400  
: IP65 - AMP JPT  
: IP69K - Deutsch DT
- Insertion . . . . . : 100%

Flying leads

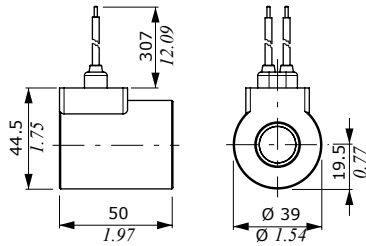

AMP JPT connector

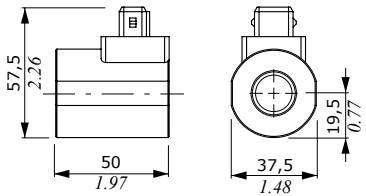

BQ16 type

ISO4400 connector

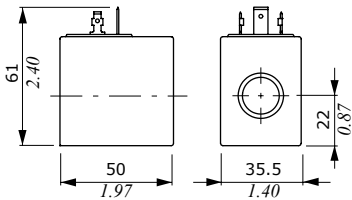

DEUTSCH DT04 connector

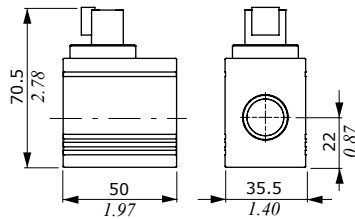

Features

- Nominal voltage tolerance : ±10%
- Power rating . . . . . : 30 W - 12/24 VDC
- Max. operating current . . . : 2.5 A - 12 VDC  
: 1.25 A - 24 VDC
- Coil insulation . . . . . : Class H (180°C - 356°F)
- Weather protection . . . . . : IP65 - ISO4400  
: IP69K - Deutsch DT  
: IP67 - Metri-pack
- Insertion . . . . . : 100%

Flying leads

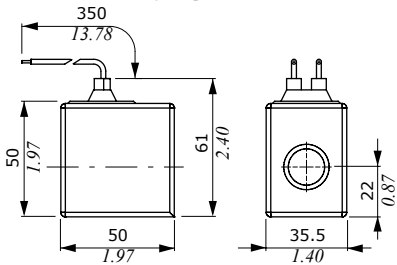

Flying leads with PACKARD METRI-PACK connector

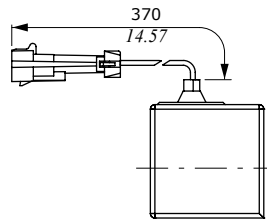

MP35 type

ISO4400 connector

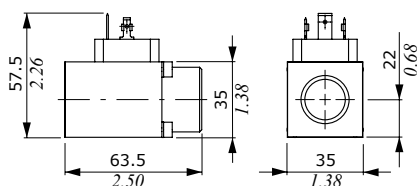

Features

- Nominal voltage tolerance : ±10%
- Power rating . . . . . : 11.2 W - 12 VDC  
: 11.4 W - 24 VDC
- Max. prop. control current : 1.25 A - 12 VDC  
: 0.68 A - 24 VDC
- Coil insulation . . . . . : Class F (155°C - 311°F)
- Weather protection . . . . . : IP65 - ISO4400
- Insertion . . . . . : 100%



### Types and dimensions

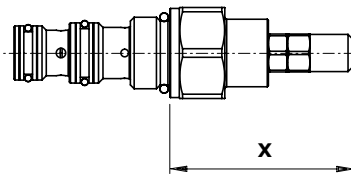

Valve type	Cavity	Dimension "X"					
		M handknob		S screw		V handwheel	
		mm	in	mm	in	mm	in
MC..A	08/2	-		53.5	2.11	83	3.46
	10/2	-		94.5	3.72	118	4.65
	12/2	-		126.5	4.98	153	56.02
MG..A	10/2	-		94.5	3.72	118	4.65
	12/2	-		126.5	4.98	150	5.91
MP..A	10/2	-		54.5	2.15	77.5	3.05
	12/2	-		52.5	2.07	75.5	2.97
	16/2	-		53	2.09	76	2.99
RB..A	08/3	-		79.5	3.13	103	4.05
	10/3	-		94.5	3.72	118	4.65
RD..A	08/3	-		79.5	3.13	103	4.05
	10/3	-		94.5	3.72	118	4.65
RM..A	10/3	-		54.5	2.15	66	2.60
	12/3	-		51.5	2.03	63	2.48
	16/3	-		50.5	1.99	62	2.44
RP..A	10/3	-		54.5	2.15	66	2.60
	12/3	-		51.5	2.03	63	2.48
RP..A	16/3	-		50.5	1.99	62	2.44
	12/3	-		51.5	2.03	63	2.48
NB..A	08/2	52	2.05	49.5	1.95	-	-
	10/2	48	1.89	46.5	1.83	-	-
	12/2	49.2	1.94	46.3	1.82	-	-
	16/2	68.8	1.94	-	-	-	-

Valve type	Cavity	Dimension "X"					
		M handknob		S screw		V handwheel	
		mm	in	mm	in	mm	in
NT..A	08/2	67.5	2.66	64.5	2.54	-	-
	10/2	68	2.68	65	2.56	-	-
	12/2	69	2.72	66	2.60	-	-
	16/2	68.9	2.71	-	-	-	-
NU..A	08/2	66.5	2.62	64.5	2.54	-	-
	10/2	68	2.68	65	2.56	-	-
	12/2	69	2.72	66	2.60	-	-
	16/2	66.9	2.63	-	-	-	-
PW..A	08/2	64.5	2.54	62	2.44	-	-
	10/2	71.9	2.83	69.4	2.73	-	-
	12/2	64.5	2.54	62	2.44	-	-
	16/2	68	2.68	65.5	2.58	-	-
PU..A	08/2	48.5	1.91	46.5	1.83	-	-
	10/2	43	1.69	41	1.61	-	-
	12/2	44	1.73	42	1.65	-	-
	16/2	52	2.05	49	1.93	-	-
PP..A	08/3	49.5	1.95	46.5	1.83	-	-
	10/3	44	1.73	41	1.61	-	-
	12/3	45	1.77	42	1.65	-	-
PP..A	16/3	52	2.05	49	1.93	-	-

Types and dimensions

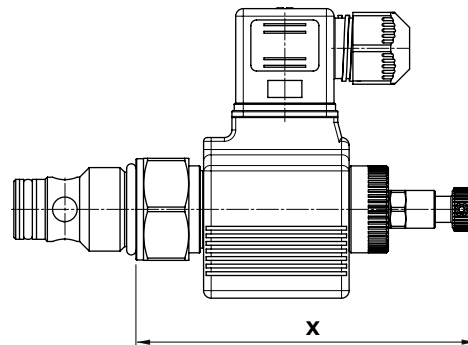

Valve type	Cavity	Dimension "X"															
		N / O without emergency		T screw type		P push button		D push type with detent		F pull button		Q pull type with detent		E with pull/push- button		V handknob	
		mm	in	mm	in	mm	in	mm	in	mm	in	mm	in	mm	in	mm	in
MC..X	10/2	86	3.39	105	4.13	-	-	-	-	-	-	-	-	-	-	-	-
MP..X	10/2	86	3.39	105	4.13	-	-	-	-	-	-	-	-	-	-	-	-
	12/2	102	4.02	121	4.76	-	-	-	-	-	-	-	-	-	-	-	-
EE..X	10/2	92.4	3.64	-	-	-	-	-	-	-	-	-	-	-	-	122	4.80
	12/2	94.9	3.74	-	-	-	-	-	-	-	-	-	-	-	-	124.5	4.90
EC..T	08/2	83	3.27	97.5	3.84	-	-	-	-	-	103.8	4.09	-	-	-	-	-
	10/2	83	3.27	97.5	3.84	-	-	-	-	-	103.8	4.09	-	-	-	-	-
	12/2	82.5	3.25	97	3.82	-	-	-	-	-	103.3	4.07	-	-	-	-	-
	16/2	81	3.19	95.5	3.76	-	-	-	-	-	101.8	4.01	-	-	-	-	-
PU..X	08/2	94	3.70	108	4.25	-	-	-	-	-	-	-	-	-	-	142	5.59
	10/2	96.4	3.79	110.4	4.35	-	-	-	-	-	-	-	-	-	-	144.4	5.69
	12/2	97.4	3.83	111.4	4.50	-	-	-	-	-	-	-	-	-	-	145.4	5.72
	16/2	121.4	4.78	135.4	5.33	-	-	-	-	-	-	-	-	-	-	169.4	6.67
PP..X	08/3	94	3.70	108	4.25	-	-	-	-	-	-	-	-	-	-	142	5.59
	10/3	96.4	3.79	110.4	4.35	-	-	-	-	-	-	-	-	-	-	144.1	5.67
	12/3	97.4	3.83	111.4	4.50	-	-	-	-	-	-	-	-	-	-	145.1	5.71
	16/3	121.4	4.78	135.4	5.33	-	-	-	-	-	-	-	-	-	-	169.4	6.67
EA..A/1	08/2	60	2.36	79.3	3.12	-	-	-	-	-	-	-	-	-	-	-	-
EA..A/2		59	2.32	79	3.11	-	-	-	-	-	-	-	-	-	-	-	-
EA..B/1		70.9	2.79	90.3	3.56	-	-	-	-	-	-	-	-	-	-	-	-
EA..B/2		65.5	2.58	90.5	3.56	-	-	-	-	-	-	-	-	-	-	-	-
EE..A/1	08/2	76	2.99	-	-	-	-	-	-	-	-	-	-	-	-	-	-
EE..A/2		76	2.99	-	-	-	-	-	-	-	-	-	-	-	-	-	-
EE..A/1	10/2	-	-	-	-	90.3	3.56	-	-	-	-	-	-	-	-	-	-
EE..A/2		-	-	-	-	90.3	3.56	-	-	-	-	-	-	-	-	-	-
EE..A/1	12/2	-	-	-	-	102	4.02	-	-	-	-	-	-	-	-	-	-
EE..A/2		-	-	-	-	90.3	3.56	-	-	-	-	-	-	-	-	-	-
EC..M/1	08/2	67.2	2.64	90.1	3.55	90.1	3.55	92.8	3.65	-	-	-	-	-	-	-	-
EF..M/1	10/2	66.9	2.63	89.8	3.54	89.8	3.54	92.5	3.64	-	-	-	-	-	-	-	-
EH..M/1	12/2	61.1	2.40	84	3.31	84	3.31	86.8	3.42	-	-	-	-	-	-	-	-
	16/2	61.2	2.40	84.1	3.31	84.1	3.31	86.9	3.42	-	-	-	-	-	-	-	-
EC..M/2	08/2	63.3	2.49	77.8	3.06	-	-	-	-	91.3	3.59	83.8	3.30	-	-	-	-
EF..M/2	10/2	63	2.48	77.5	3.05	-	-	-	-	91	3.58	83.5	3.29	-	-	-	-
EH..M/2	12/2	57.2	2.25	71.7	2.82	-	-	-	-	85.2	3.35	77.7	3.06	-	-	-	-
	16/2	57.3	2.26	71.8	2.83	-	-	-	-	85.3	3.36	77.8	3.06	-	-	-	-
EW08A/1	08/2	65.7	2.59	73.5	2.89	-	-	-	-	-	-	-	-	-	-	-	-
EW08A/2	08/2	70.9	2.79	90.3	3.56	87.2	3.43	-	-	-	-	-	-	-	-	-	-
EW10B/1	10/2	99.8	3.93	-	-	-	-	-	-	-	-	-	-	-	-	-	-
EW10A/2	10/2	-	-	-	-	83.3	3.28	-	-	-	-	-	-	-	-	-	-

### Types and dimensions

Valve type	Cavity	Dimension "X"															
		N / O without emergency		T screw type		P push button		D push type with detent		F pull button		Q pull type with detent		E with pull/push- button		V handknob	
		mm	in	mm	in	mm	in	mm	in	mm	in	mm	in	mm	in	mm	in
EW12B/1	12/2	102.8	4.05	-	-	-	-	-	-	-	-	-	-	-	-	-	-
EW12C/2	12/2	-	-	-	-	98.7	3.89	-	-	-	-	-	-	-	-	-	-
EW08M/1	08/2	60.1	2.37	77	3.03	-	-	-	-	88.1	3.47	81	3.19	-	-	-	-
EW08M/2	08/2	62.5	2.46	85.4	3.36	85.4	3.36	88.1	3.47	-	-	-	-	-	-	-	-
EW10M/2	10/2	81.3	3.20	95.3	3.75	104.2	4.10	106.3	4.19	-	-	-	-	-	-	-	-
EJ08F	08/3	65.7	2.59	73.5	2.89	-	-	-	-	-	-	-	-	-	-	-	-
EJ08G	08/3	65.7	2.59	73.5	2.89	-	-	-	-	-	-	-	-	-	-	-	-
EJ..M	08/3	56.1	2.21	70.6	2.78	-	-	-	-	84.1	3.31	77	3.03	-	-	-	-
	10/3	68	2.68	82.5	3.25	-	-	-	-	96	3.78	88.9	3.50	-	-	-	-
EL08A	08/3	94.9	3.74	-	-	96	3.78	-	-	-	-	-	-	-	-	-	-
EL10C	10/3	86.7	3.41	-	-	-	-	-	-	-	-	-	-	-	-	-	-
EL08B	08/3	65.7	2.59	73.5	2.89	-	-	-	-	-	-	-	-	-	-	-	-
	08/4	75	2.95	100	3.94	-	-	-	-	115.5	4.55	95.8	3.77	-	-	-	-
ER..M	10/4	89	3.50	110.5	4.35	-	-	-	-	129.5	5.10	110	4.35	-	-	-	-
	12/4	85.5	3.37	-	-	-	-	-	-	-	-	-	-	-	-	-	-
ET..M	08/4	120	4.72	-	-	121	4.76	165	6.50	-	-	-	-	165.6	6.52	-	-
	10/4	148.5	5.85	-	-	149.5	5.89	190.9	7.52	-	-	-	-	191.5	7.54	-	-
	12/4	156	6.14	-	-	156	6.14	-	-	-	-	-	-	-	-	-	-

Dimensions and ordering codes

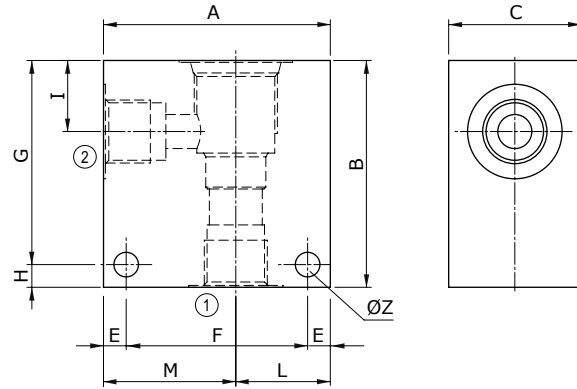
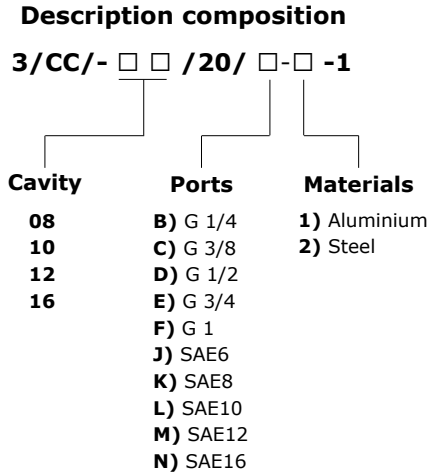

Material	Max. pressure	
	bar	psi
Aluminium	210	3050
Steel	350	5100

Cavity	Ports	Dimensions											Ordering code		
		A	B	C	E	F	G	H	I	L	M	ØZ	Aluminium	Steel	
SAE 08/2	G 1/4	mm	50	50	30	6	38	44	6	14.8	20	30	6.5	3CC0820B11	3CC0820B21
		in	1.97	1.97	1.18	0.24	1.50	1.73	0.24	0.58	0.79	1.18	0.26		
	G 3/8	mm	50	50	30	6	38	44	6	14.8	20	30	6.5	3CC0820C11	3CC0820C21
		in	1.97	1.97	1.18	0.24	1.50	1.73	0.24	0.58	0.79	1.18	0.26		
	G 1/2	mm	60	60	35	6	48	54	6	18	25	35	6.5	3CC0820D11	/
		in	2.36	2.36	1.38	0.24	1.89	2.16	0.24	0.71	0.98	1.38	0.26		
SAE6	mm	50	50	30	6	38	44	6	14.8	20	30	6.5	3CC0820J11	3CC0820J21	
	in	1.97	1.97	1.18	0.24	1.50	1.73	0.24	0.58	0.79	1.18	0.25			
SAE8	mm	60	60	30	6	48	54	6	14	25	35	6.5	3CC0820K11	3CC0820K21	
	in	2.36	2.36	1.18	0.24	1.89	2.16	0.24	0.55	0.98	1.38	0.25			
SAE 10/2	G 1/4	mm	60	60	35	6	48	54	6	18.8	25	35	6.5	3CC1020B11	3CC1020B21
		in	2.36	2.36	1.38	0.24	1.89	2.12	0.24	0.74	0.98	1.38	0.26		
	G 3/8	mm	60	60	35	6	48	54	6	18.8	25	35	6.5	3CC1020C11	3CC1020C21
		in	2.36	2.36	1.38	0.24	1.89	2.12	0.24	0.74	0.98	1.38	0.26		
	G 1/2	mm	60	60	35	6	48	54	6	18.8	25	35	6.5	3CC1020D11	3CC1020D21
		in	2.36	2.36	1.38	0.24	1.89	2.12	0.24	0.74	0.98	1.38	0.26		
	SAE6	mm	60	70	35	6	48	64	6	18.8	25	35	6.5	3CC1020J11	3CC1020J21
		in	2.36	2.75	1.38	0.24	1.89	2.52	0.24	0.74	0.98	1.38	0.26		
	SAE8	mm	70	70	35	6	58	64	6	18.5	35	35	6.5	3CC1020K11	3CC1020K21
		in	2.75	2.75	1.38	0.24	2.28	2.52	0.24	0.73	1.38	1.38	0.26		
	SAE10	mm	70	70	40	8	54	62	8	22	30	40	8.5	3CC1020L11	3CC1020L21
		in	2.75	2.75	1.57	0.31	2.12	2.44	0.31	0.87	1.18	1.57	0.33		

## Dimensions and ordering codes

Cavity	Ports	Dimensions											Ordering code		
		A	B	C	E	F	G	H	I	L	M	ØZ	Aluminium	Steel	
SAE 12/2	G 1/2	mm	70	80	40	8	54	72	8	25	30	40	8.5	3CC1220D11	3CC1220D21
		in	2.75	3.15	1.57	0.31	2.12	2.83	0.31	0.98	1.18	1.57	0.33		
	G 3/4	mm	70	90	40	8	54	82	8	25	30	40	8.5	3CC1220E11	3CC1220E21
		in	2.75	3.54	1.57	0.31	2.12	3.23	0.31	0.98	1.18	1.57	0.33		
	SAE10	mm	70	85	40	8	54	77	8	25	30	40	8.5	3CC1220L11	3CC1220L21
		in	2.75	3.35	1.57	0.31	2.12	3.03	0.31	0.98	1.18	1.57	0.33		
	SAE12	mm	70	85	40	8	54	77	8	25	30	40	8.5	3CC1220M11	3CC1220M21
		in	2.75	3.35	1.57	0.31	2.12	3.03	0.31	0.98	1.18	1.57	0.33		
SAE 16/2	G 1/2	mm	80	90	50	10	60	80	10	25	35	45	10.5	3CC1620D11	3CC1620D21
		in	3.15	3.54	1.97	0.39	2.36	3.15	0.39	0.98	1.38	1.77	0.41		
	G 3/4	mm	80	90	50	10	60	80	10	25	35	45	10.5	3CC1620E11	3CC1620E21
		in	3.15	3.54	1.97	0.39	2.36	3.15	0.39	0.98	1.38	1.77	0.41		
	G 1	mm	85	100	60	10	65	90	10	23.5	40	45	10.5	3CC1620F11	3CC1620F210
		in	3.35	3.94	2.36	0.39	2.56	3.54	0.39	0.92	1.57	1.77	0.41		
	SAE12	mm	80	90	50	10	60	80	10	25	35	45	10.5	3CC1620M11	3CC1620M21
		in	3.15	3.54	1.97	0.39	2.36	3.15	0.39	0.98	1.38	1.77	0.41		
	SAE16	mm	80	100	50	10	60	90	10	25	35	45	10.5	3CC1620N11	3CC1620N21
		in	3.15	3.94	1.97	0.39	2.36	3.54	0.39	0.98	1.38	1.77	0.41		



**Dimensions and ordering codes**

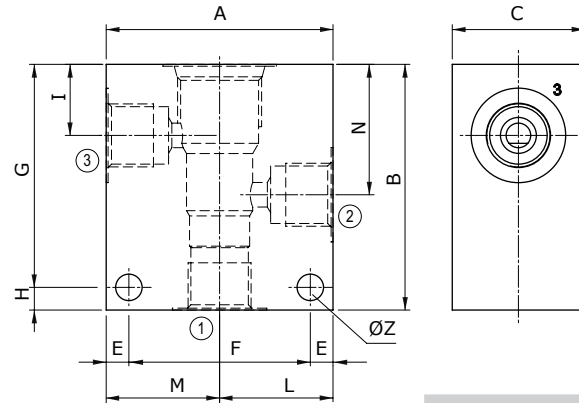
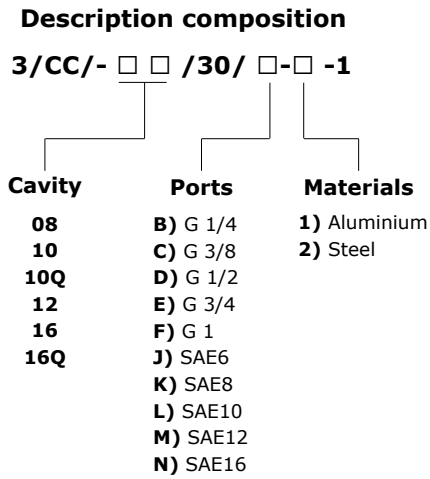

Material	Max. pressure	
	bar	psi
Aluminium	210	3050
Steel	350	5100

Cavity	Ports	Dimensions												Ordering code		
		A	B	C	E	F	G	H	I	L	M	N	ØZ	Aluminium	Steel	
SAE 08/3	G 1/4	mm	60	60	30	7	46	48	12	14.8	30	30	29.1	6.5	3CC0830B11	3CC0830B21
		in	2.36	2.36	1.18	0.27	1.81	1.89	0.47	0.58	1.18	1.18	1.14	0.25		
	G 3/8	mm	60	60	30	7	46	48	12	14.5	30	30	29.1	6.5	3CC0830C11	3CC0830C21
		in	2.36	2.36	1.18	0.27	1.81	1.89	0.47	0.57	1.18	1.18	1.14	0.25		
	G 1/2	mm	70	65	35	7	56	53	12	14.5	35	35	29.1	6.5	3CC0830D11	/
		in	2.75	2.56	1.38	0.27	2.20	2.09	0.47	0.57	1.38	1.38	1.14	0.25		
SAE6	mm	60	60	30	7	46	48	12	14.5	30	30	29.1	6.5	3CC0830J11	3CC0830J21	
	in	2.36	2.36	1.18	0.27	1.81	1.89	0.47	0.57	1.18	1.18	1.14	0.25			
SAE8	mm	60	60	30	7	46	48	12	15	30	30	29	6.5	3CC0830K11	3CC0830K11	
	in	2.36	2.36	1.18	0.27	1.81	1.89	0.47	0.59	1.18	1.18	1.14	0.25			
SAE 08/3C	G 3/8	mm	60	50	30	7	46	40	10	14.5	30	30	22	6.5	3CC0833C11	/
		in	2.36	1.97	1.18	0.27	1.81	1.57	0.39	0.57	1.18	1.18	0.87	0.25		
SAE 10/3	G 1/4	mm	60	65	35	6	48	59	6	18	30	30	34.5	7	3CC1030B11	3CC1030B21
		in	2.36	2.56	1.38	0.24	1.89	2.32	0.24	0.70	1.18	1.18	1.36	0.27		
	G 3/8	mm	60	65	35	6	48	59	6	18.8	30	30	34.5	7	3CC1030C11	3CC1030C21
		in	2.36	2.56	1.38	0.24	1.89	2.32	0.24	0.74	1.18	1.18	1.36	0.27		
	G 1/2	mm	65	70	35	6	53	64	6	18.8	32.5	32.5	34.5	7	3CC1030D11	3CC1030D21
		in	2.56	2.75	1.38	0.24	2.09	2.52	0.24	0.74	1.28	1.28	1.36	0.27		
	SAE6	mm	65	70	35	6	53	64	6	18.8	32.5	32.5	34.5	7	3CC1030J11	3CC1030J21
		in	2.56	2.75	1.38	0.24	2.09	2.52	0.24	0.74	1.28	1.28	1.36	0.27		
	SAE8	mm	65	70	35	6	53	64	6	18.8	32.5	32.5	34.5	7	3CC1030K11	3CC1030K21
		in	2.56	2.75	1.38	0.24	2.09	2.52	0.24	0.74	1.28	1.28	1.36	0.27		
SAE10	mm	65	70	35	6	53	64	6	18	31.5	33.5	34.5	7	3CC1030L11	3CC1030L21	
	in	2.56	2.75	1.38	0.24	2.09	2.52	0.24	0.70	1.24	1.32	1.36	0.27			

## Dimensions and ordering codes

Cavity	Ports		Dimensions											Ordering code			
			A	B	C	E	F	G	H	I	L	M	N	ØZ	Aluminium	Steel	
SAE 10/3Q	ports 1-2 = G 1/2 port 3 = G 1/4	mm	60	70	35	6	48	64	6	14,8	30	30	31.7	7	/	3CC1032D21	
		in	2.36	2.75	1.38	0.24	1.89	2.52	0.24	0.58	1.18	1.18	1.25	0.27			
SAE 12/3	G 1/2	mm	70	100	40	8	54	92	8	25	35	35	53.5	8.5	3CC1230D11	3CC1230D21	
		in	2.75	3.94	1.57	0.31	2.12	3.6	0.31	0.98	1.38	1.38	2.10	0.33			
	G 3/4	mm	90	100	50	10	70	90	10	25.1	45	45	53.5	10.5	3CC1230E11	3CC1230E21	
		in	3.54	3.94	1.97	0.39	2.75	3.54	0.39	0.99	1.77	1.77	2.11	0.41			
	SAE10	mm	80	100	40	8	64	92	8	25	40	40	53.5	8.5	3CC1230L11	3CC1230L21	
		in	3.15	3.94	1.57	0.31	2.52	3.6	0.31	0.98	1.57	1.57	2.11	0.33			
	SAE12	mm	80	100	45	8	64	92	8	25	40	40	53.5	8.5	3CC1230M11	3CC1230M21	
		in	3.15	3.94	1.77	0.31	2.52	3.6	0.31	0.98	1.57	1.57	2.11	0.33			
	SAE16/3	G 1/2	mm	90	100	50	10	70	90	10	25	45	45	53.5	10.5	3CC1630D11	3CC1630D21
			in	3.54	3.94	1.97	0.39	2.75	3.54	0.39	0.98	1.77	1.77	2.11	0.41		
G 3/4		mm	90	100	50	10	70	90	10	25.1	45	45	53.5	10.5	3CC1630E11	3CC1630E21	
		in	3.54	3.94	1.97	0.39	2.75	3.54	0.39	0.99	1.77	1.77	2.11	0.41			
G 1		mm	90	105	50	10	70	95	10	25	46	44	53.5	10.5	3CC1630F11	3CC1630F21	
		in	3.54	4.13	1.97	0.39	2.75	3.74	0.39	0.98	1.81	1.73	2.11	0.41			
SAE12		mm	90	105	50	10	70	95	10	25.1	45	45	53.5	10.5	3CC1630M11	3CC1630M21	
		in	3.54	4.13	1.97	0.39	2.75	3.74	0.39	0.99	1.77	1.77	2.11	0.41			
SAE16		mm	90	105	50	10	70	95	10	25.1	45	45	53.5	10.5	3CC1630N11	3CC1630N21	
		in	3.54	4.13	1.97	0.39	2.75	3.74	0.39	0.99	1.77	1.77	2.11	0.41			
SAE 16/3Q	ports 1-2 = G 3/4 port 3 = G 1/4	mm	80	85	50	10	60	75	10	17.2	40	40	38.1	10.5	/	3CC1632E21	
		in	3.15	3.35	1.97	0.39	2.36	2.95	0.39	0.68	1.57	1.57	1.50	0.41			

Dimensions and ordering codes

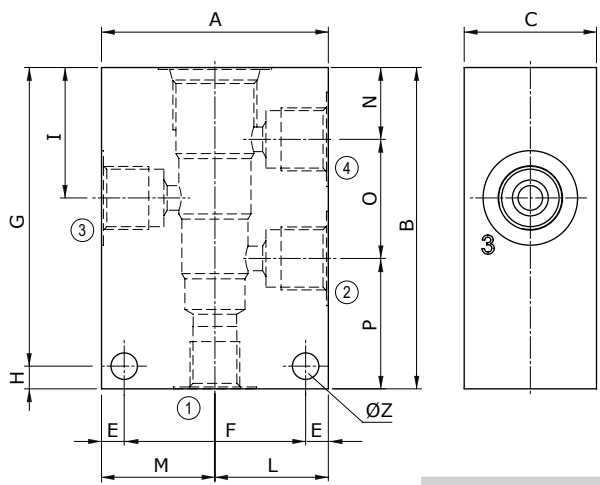
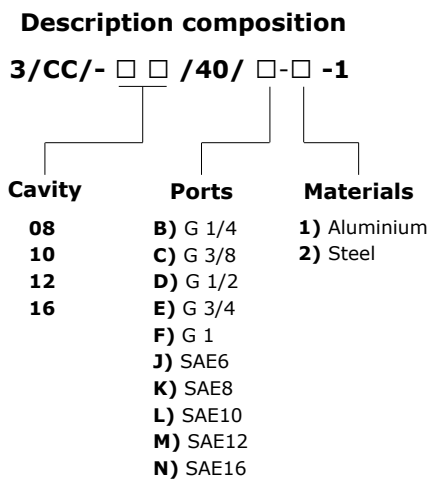

Material	Max. pressure	
	bar	psi
Aluminium	210	3050
Steel	350	5100

Cavity	Ports	Dimensions														Ordering code		
		A	B	C	E	F	G	H	I	L	M	N	O	P	ØZ	Aluminium	Steel	
SAE 08/4	G 1/4	mm	60	75	30	7	46	63	12	29.1	30	30	14.8	29.1	31.1	6.5	3CC0840B11	3CC0840B21
		in	2.36	2.95	1.18	0.27	1.81	2.48	0.47	1.14	1.18	1.18	0.58	1.14	1.22	0.25		
	G 3/8	mm	60	75	30	7	46	63	12	29.1	30	30	14.8	28.6	31.6	6.5	3CC0840C11	3CC0840C21
		in	2.36	2.95	1.18	0.27	1.81	2.48	0.47	1.14	1.18	1.18	0.58	1.13	1.24	0.25		
	SAE6	mm	60	75	30	7	46	63	12	29.1	30	30	14.8	29.1	31.1	6.5	3CC0840J11	3CC0840J21
		in	2.36	2.95	1.18	0.27	1.81	2.48	0.47	1.14	1.18	1.18	0.58	1.14	1.22	0.25		
	SAE8	mm	60	75	30	7	46	63	12	29	30	30	15	28.5	31.5	6.5	3CC0840K11	3CC0840K21
		in	2.36	2.95	1.18	0.27	1.81	2.48	0.47	1.14	1.18	1.18	0.59	1.12	1.24	0.25		
SAE 10/4	G 1/4	mm	60	85	35	6	48	79	6	34.5	30	30	19	31.5	34.5	7	3CC1040B11	3CC1040B21
		in	2.36	3.35	1.38	0.24	1.89	3.11	0.24	1.36	1.18	1.18	0.75	1.24	1.36	0.27		
	G 3/8	mm	60	85	35	6	48	79	6	34.5	30	30	18.8	31.7	34.5	7	3CC1040C11	3CC1040C21
		in	2.36	3.35	1.38	0.24	1.89	3.11	0.24	1.36	1.18	1.18	0.74	1.25	1.36	0.27		
	G 1/2	mm	70	85	35	6	58	79	6	34.5	35	35	18.8	31.7	34.5	7	3CC1040D11	3CC1040D21
		in	2.75	3.35	1.38	0.24	2.28	3.11	0.24	1.36	1.38	1.38	0.74	1.25	1.36	0.27		
	SAE6	mm	60	85	35	6	48	79	6	34.5	30	30	18.8	31.7	34.5	7	3CC1040J11	3CC1040J21
		in	2.36	3.35	1.38	0.24	1.89	3.11	0.24	1.36	1.18	1.18	0.74	1.25	1.36	0.27		
	SAE8	mm	70	85	35	6	58	79	6	34.5	35	35	18.8	31.7	34.5	7	3CC1040K11	3CC1040K21
		in	2.75	3.35	1.38	0.24	2.28	3.11	0.24	1.36	1.38	1.38	0.74	1.25	1.36	0.27		
SAE10	mm	70	85	35	6	58	79	6	34.5	35	35	19	31.5	34.5	7	3CC1040L11	3CC1040L11	
	in	2.75	3.35	1.38	0.24	2.28	3.11	0.24	1.36	1.38	1.38	0.75	1.24	1.36	0.27			

## Dimensions and ordering codes

Cavity	Ports	Dimensions															Ordering code	
		A	B	C	E	F	G	H	I	L	M	N	O	P	ØZ	Aluminium	Steel	
SAE 12/4	G 3/8	mm	80	115	40	8	64	107	8	44	40	40	22	44.5	48.5	8.5	3CC1240C11	3CC1240C21
		in	3.15	4.53	1.57	0.31	2.52	4.21	0.31	1.73	1.57	1.57	0.87	1.75	1.9	0.33		
	G 1/2	mm	80	115	40	8	64	107	8	44	40	40	22	44.5	48.5	8.5	3CC1240D11	3CC1240D21
		in	3.15	4.53	1.57	0.31	2.52	4.21	0.31	1.73	1.57	1.57	0.87	1.75	1.9	0.33		
	SAE10	mm	80	115	40	8	64	107	8	44	40	40	22	44.5	48.5	8.5	3CC1240L11	3CC1240L21
		in	3.15	4.53	1.57	0.31	2.52	4.21	0.31	1.73	1.57	1.57	0.87	1.75	1.9	0.33		
SAE 16/4	G 3/4	mm	100	130	50	10	80	120	10	53.5	50	50	25.1	56.9	48	10.5	3CC1640E11	3CC1640E21
		in	3.94	5.12	1.97	0.39	3.15	4.72	0.39	2.11	1.97	1.97	0.99	2.24	1.89	0.41		
	SAE16	mm	100	130	50	10	80	120	10	53.5	50	50	25.1	56.9	48	10.5	3CC1640N11	3CC1640N21
		in	3.94	5.12	1.97	0.39	3.15	4.72	0.39	2.11	1.97	1.97	0.99	2.24	1.89	0.41		

How to order valves with body

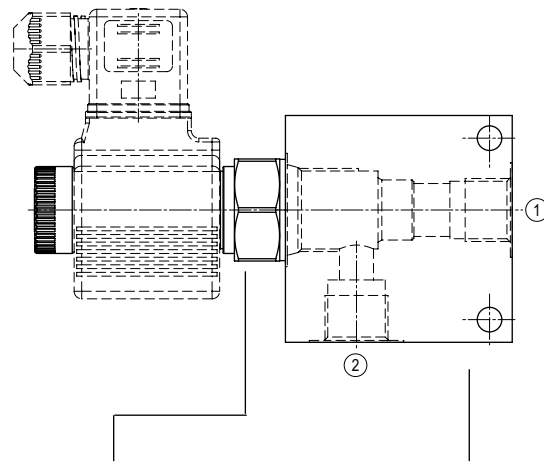

**Cartridge description**

**Body description**

**EC 10 M/10NB**

**C 1 1**

**Cavity**

- 08
- 10
- 12
- 16

**Ports**

- B) G 1/4
- C) G 3/8
- D) G 1/2
- E) G 3/4
- F) G 1
- J) SAE6
- K) SAE8
- L) SAE10
- M) SAE12
- N) SAE16

**Materials**

- 1) Aluminium
- 2) Steel

## Dimensions

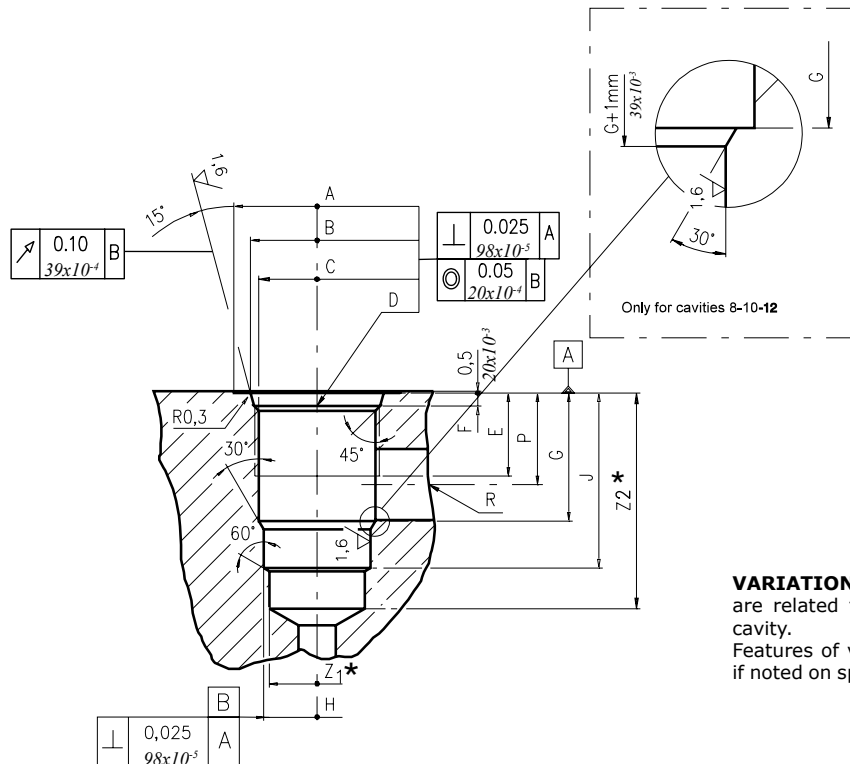

**VARIATION "A"**: the dimensions with "\*" are related to the variation "A" of 2 way cavity. Features of variation "A" are required only if noted on specific product catalogue page.

Cavity	A	B ±0.05	C ±0.05	D	E	F	G	H ±0.02	J	K ±0.02	L	M ±0.02	N	P	R ØMAX	S	T ØMAX	U	V ØMAX	X ØMAX	Z1* ØMIN	Z2* MIN
08/2	mm 27	20.66	17.42	3/4-16 UNF	12.5	2.5	18.2	12.72	29.5	-	-	-	-	14	8	-	-	-	-	-	12	39
08/2 A	in 1.06	0.81	0.68		0.49	0.10	0.72	0.50	1.16	-	-	-	-	0.55	0.31	-	-	-	-	-	0.47	1.53
10/2	mm 30	24	20.62	7/8-14 UNF	16	2.8	24	15.9	33.5	-	-	-	-	18.3	11	-	-	-	-	-	14.5	40
10/2 A	in 1.18	0.94	0.81		0.63	0.11	0.94	0.62	1.32	-	-	-	-	0.72	0.43	-	-	-	-	-	0.57	1.57
12/2	mm 38	29.23	24.73	1 1/16-12 UNF	19	3.5	34.15	22.25	46.8	-	-	-	-	24.5	19	-	-	-	-	-	21.5	60
12/2 A	in 1.50	1.15	0.97		0.75	0.14	1.34	0.87	1.84	-	-	-	-	0.96	0.75	-	-	-	-	-	0.85	2.36
16/2	mm 45	35.6	31.34	1 5/16-12 UNF	22	3.50	34	28.62	47	-	-	-	-	24.5	19	-	-	-	-	-	25.5	70
16/2 A	in 1.77	1.40	1.23		0.87	0.14	1.34	1.13	1.85	-	-	-	-	0.96	0.75	-	-	-	-	-	1.00	2.75

### Rougher tool

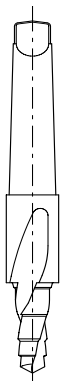

Cavity	Ordering code
08/2	UDPF175030
08/2A	UDPF175030
10/2	UDPF20503F
10/2A	UDAS24003C
12/2	UDAS380031
12/2A	UDAS380031
16/2	UDPF313031
16/2A	UDPF313031

### Finisher tool



Cavity	Ordering code
08/2	UCAC127066
08/2A	UCAC127060
10/2	UCAC159080
10/2A	UCAC159080
12/2	UDAC222661
12/2A	UDAC222661
16/2	UDAC286261
16/2A	UDAC286261

### Tap



Cavity	Ordering code
08/2	UCMS3/4161
08/2A	UCMS3/4161
10/2	UCMS7/8142
10/2A	UCMS7/8142
12/2	UCMS11/162
12/2A	UCMS11/162
16/2	UCMS15/160
16/2A	UCMS15/160

### Cavity plugs

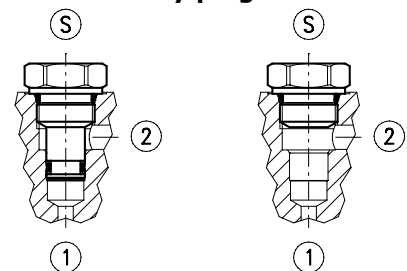

Cavity	Ordering code	①	②	Ⓢ
08/2	3XTP3533700	X	X	X
08/2A	4TP5531500	0	0	X
10/2	3XTP3544200	X	X	X
10/2A	3XTP1542300	0	0	X
12/2	3XTP3555400	X	X	X
12/2A	3XTP1552900	0	0	X
16/2	3XTP3575500	X	X	X
16/2A	3XTAP838200	0	0	X

X=Close 0=Open

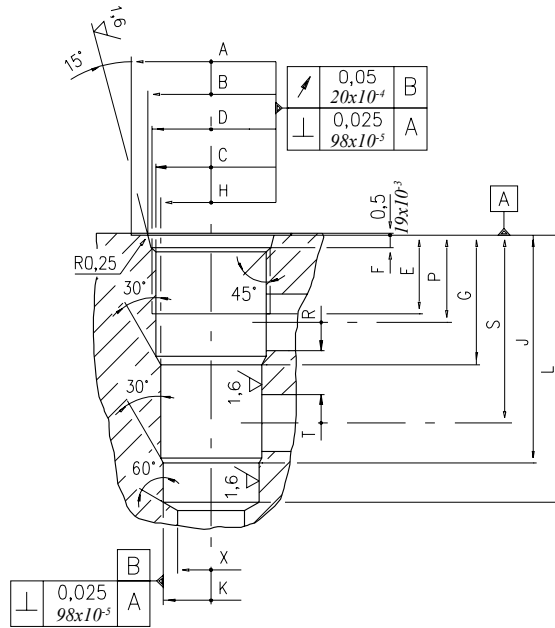

Cavity	A	B ±0,05	C ±0,05	D	E	F	G	H ±0,02	J	K ±0,02	L	M ±0,02	N	P	R øMAX	S	T øMAX	U	V øMAX	X øMAX	
08/3	mm	27	20.66	17.42	3/4 -16 UNF	12.5	2.5	19.1	15.90	33.3	14.3	43.3	-	-	14.3	5.5	28.6	5.5	-	-	12.5
	in	1.06	0.81	0.68		0.49	0.10	0.75	0.62	1.31	0.56	1.70	-	-	0.56	0.22	1.12	0.22	-	-	0.49
08/3C	mm	27	20.66	17.42	3/4 -16 UNF	10	2.5	14.3	15.9	25.2	14.3	31.5	-	-	10.5	5	21.5	5	-	-	12.5
	in	1.06	0.81	0.68		0.39	0.10	0.56	0.62	1.31	0.56	1.70	-	-	0.41	0.20	0.85	0.20	-	-	0.49
10/3	mm	30	24	20.62	7/8 -14 UNF	16	2.8	23.1	17.5	39.6	15.9	47.6	-	-	18.3	6.5	34	6.5	-	-	14
	in	1.18	0.94	0.81		0.63	0.11	0.94	0.69	1.56	0.62	1.87	-	-	0.72	0.25	1.34	0.25	-	-	0.55
12/3	mm	38	29.23	24.73	1 1/16 -12 UNF	19	3.56	36.6	23.82	63.5	22.25	75.4	-	-	24.5	16	53	16	-	-	19
	in	1.50	1.15	0.97		0.75	0.14	1.44	0.94	2.5	0.88	2.97	-	-	0.96	0.63	2.09	0.63	-	-	0.75
16/3	mm	45	35.6	28.62	1 5/16 -12 UNF	22	3.5	36.5	28.62	64.3	27.02	75.3	-	-	24.5	16	53	16	-	-	19
	in	1.77	1.40	1.13		0.87	0.14	1.44	1.13	2.53	1.06	2.96	-	-	0.96	0.63	2.09	0.63	-	-	0.75
20/3	mm	58	43.6	36.55	1 5/8 -12 UNF	21	3.5	46	36.55	87.6	33.37	100	-	-	31	25.4	71.5	25.4	-	-	30
	in	2.28	1.71	1.44		0.83	0.14	1.81	1.04	3.45	1.31	3.93	-	-	1.22	1	2.81	1	-	-	1.18

**Cavity plugs**

**Rougher tool**

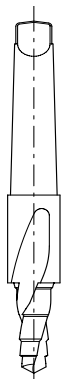

Cavity	Ordering code
08/3	UDAS207021
08/3C	UDPF174021
10/3	UDPF20503B
12/3	UDAS380032
16/3	UDAS450032
20/3	UT05X55380

**Finisher tool**



Cavity	Ordering code
08/3	UDAS159064
08/3C	UDAS159063
10/3	UDAC175080
12/3	UDAS238060
16/3	UDAS286261
20/3	UT05X55390

**Tap**

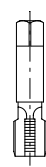

Cavity	Ordering code
08/3	UCMS3/4161
08/3C	UCMS3/4161
10/3	UCMS7/8142
12/3	UCMS11/162
16/3	UCMS15/160
20/3	UCMS15/812

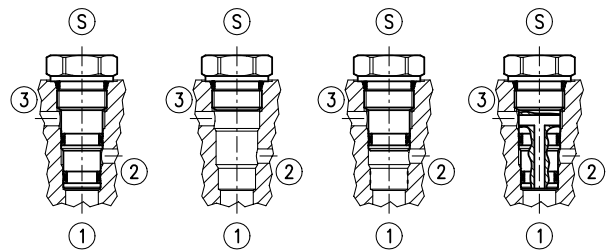

Cavity	Ordering code	①	②	③	S
08/3	XTAP324541	X	X	X	X
	3XTAP822150	0	0	0	X
	XTAP324400	0	0	X	X
08/3C	XTAP324540	0	X	0	X
	XTAP824370	X	X	X	X
10/3	3XTAP822150	0	0	0	X
	3XTP3545700	X	X	X	X
	3XTP1542300	0	0	0	X
12/3	3XTP3545701	0	X	0	X
	3XTP3558200	X	X	X	X
	3XTP1552900	0	0	0	X
16/3	3XTP3558201	0	X	0	X
	3XTP3578400	X	X	X	X
	3XTAP838200	0	0	0	X

X=Close 0=Open

## Dimensions

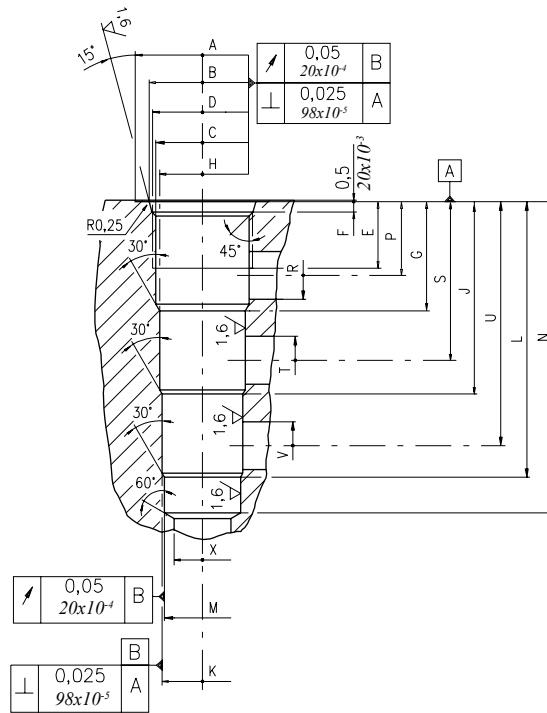

Cavity	A	B ±0,05	C ±0,05	D	E	F	G	H ±0,02	J	K ±0,02	L	M ±0,02	N	P	R øMAX	S øMAX	T øMAX	U	V øMAX	X øMAX	
08/4	mm	28.00	20.66	17.42	3/4-16 UNF	12.5	2.5	19.1	15.9	33.3	14.3	47.6	12.72	57.6	14.3	5.5	28.6	5.5	42.9	5.5	11
	in	1.10	0.81	0.68		0.49	0.10	0.75	0.62	1.31	0.56	1.87	0.50	2.27	0.56	0.22	1.12	0.22	1.69	0.22	0.43
10/4	mm	30	24.00	20.62	7/8-14 UNF	16	2.8	23.6	19.08	39.6	17.5	55.4	15.9	63.5	18.3	6.5	34	6.5	50	6.5	14
	in	1.18	0.94	0.81		0.63	0.11	0.93	0.75	1.56	0.69	2.18	0.62	2.50	0.72	0.26	1.34	0.25	1.97	0.25	0.55
12/4	mm	38	29.23	24.73	1 1/16-12 UNF	19	3.56	29.5	23.82	51.5	22.25	73.6	20.65	83.33	21.5	11	43.5	11	66	11	19
	in	1.50	1.15	0.97		0.75	0.14	1.16	0.94	2.03	0.87	2.90	0.81	3.28	0.85	0.43	1.71	0.43	2.60	0.43	0.75
16/4	mm	45	35.60	31.34	1 5/16-12 UNF	22	3.5	36.5	28.62	64.3	27.02	92.07	25.45	104	24.6	16	53	16	81.5	16	19
	in	1.77	1.40	1.23		0.87	0.14	1.44	1.13	2.53	1.06	3.62	1.00	4.09	0.97	0.63	2.09	0.63	3.21	0.63	0.75

## Cavity plugs

### Rougher tool

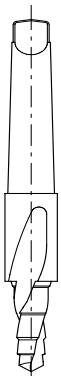

### Finisher tool



### Tap

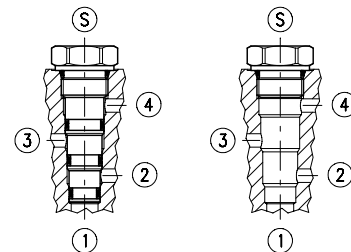
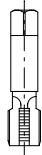

Cavity	Ordering code	①	②	③	④	Ⓢ
08/4	3XTP3536500	X	X	X	X	X
	3XTAP822150	0	0	0	0	X
10/4	3XTP3548301	X	X	X	X	X
	3XTP1542300	0	0	0	0	X
12/4	3XTP3559300	X	X	X	X	X
	3XTP1552900	0	0	0	0	X
16/4	3XTP357B300	X	X	X	X	X
	3XTAP838200	0	0	0	0	X

X=Close 0=Open











Innovation · Continuity · Integration  
————— It is Power —————

 **walvoil**  
FLUID POWER E|MOTION

 **walvoil**

 **hydro control**

 **Galtech**  
INNOVATION

D1WWEI01E  
13<sup>th</sup> edition May 2020

Walvoil S.P.A. • 42124 Reggio Emilia • Italy • Via Adige, 13/D • Tel. +39.0522.932411 • Fax +39.0522.300984  
[www.walvoil.com](http://www.walvoil.com)

